

# INSTRUCTION FOR ASSEMBLY

120x150 v Traditional sauna cabin

"TRENDLINE"



# 1. SAUNA PLAN

## 120x150v TRADITIONAL SAUNACABIN "Trendline" View from the top

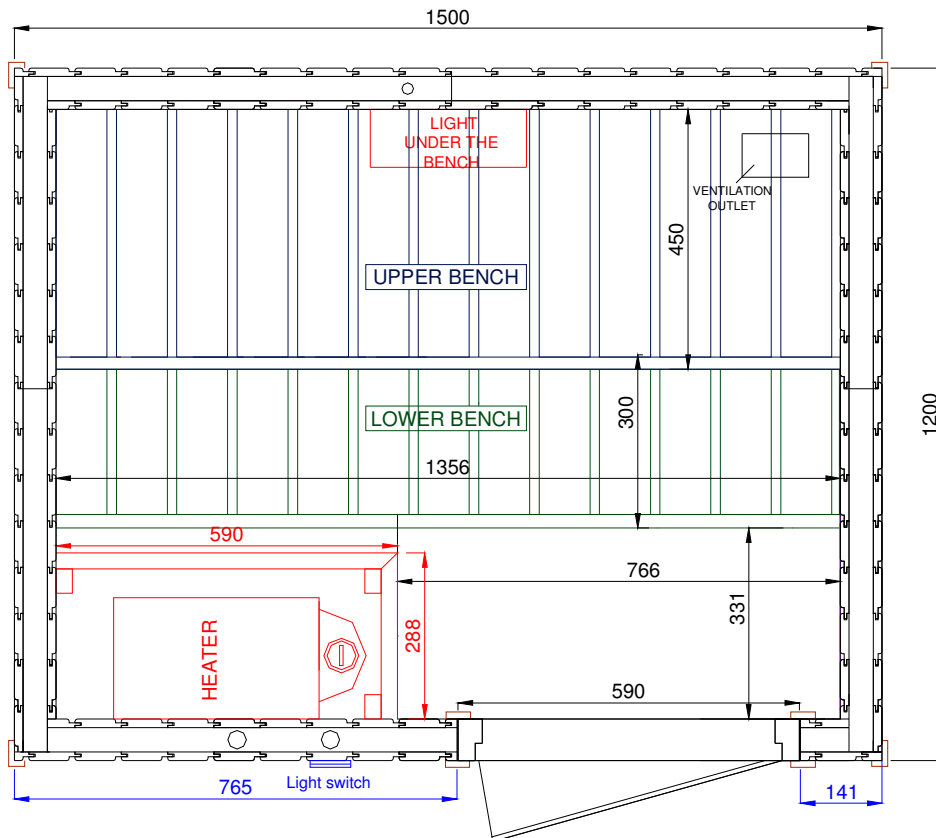

OUTSIDE HEIGHT: 2050 mm + 30 mm adjustable screw

Wall panelling STP 15×90 spruce, vertical

Bench material SHP 21×90 aspen, short board

Full glass sauna door 6×19, tempered 8 mm bronze glass, Trendline handle, Abloy hinges

Sauna includes upper and lower bench, heater guard, sauna lamp with shade under the bench, light switch

**TOOLS REQUIRED:** Hammer or pin nailer  
Drill or cordless screwdriver  
Tape measure  
Square  
Level  
Handsaw

## 2. BASE FRAME

There are 4 details for the base frame. Fasten the three corners together with the screws (4,0x30 mm). Cross-measure from the corners to check that they are at straight angle. Correct the corners if necessary and screw the last screw in. Check that the base frame is level using a spirit level.

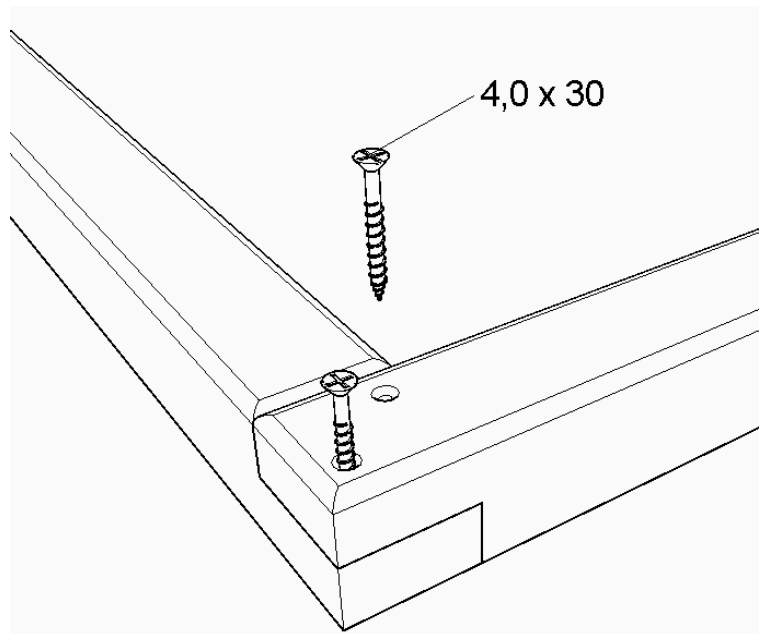
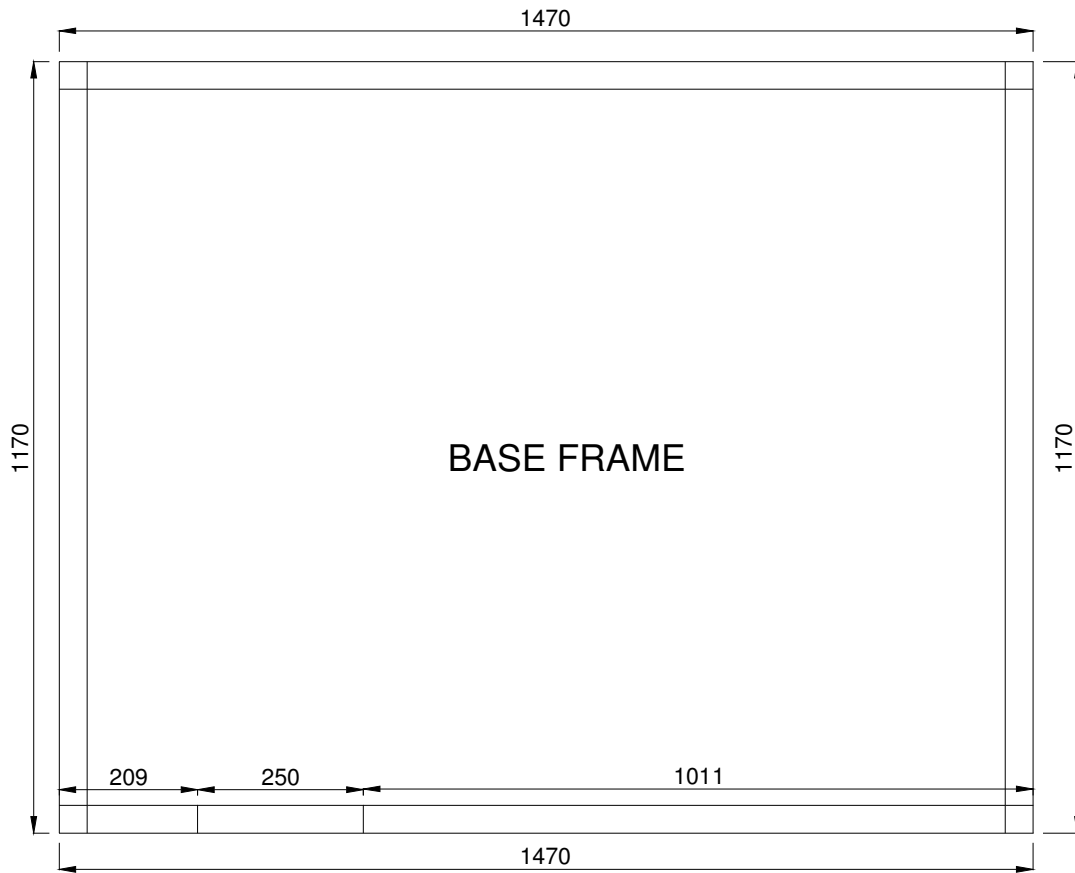

### 3. WALL ELEMENTS

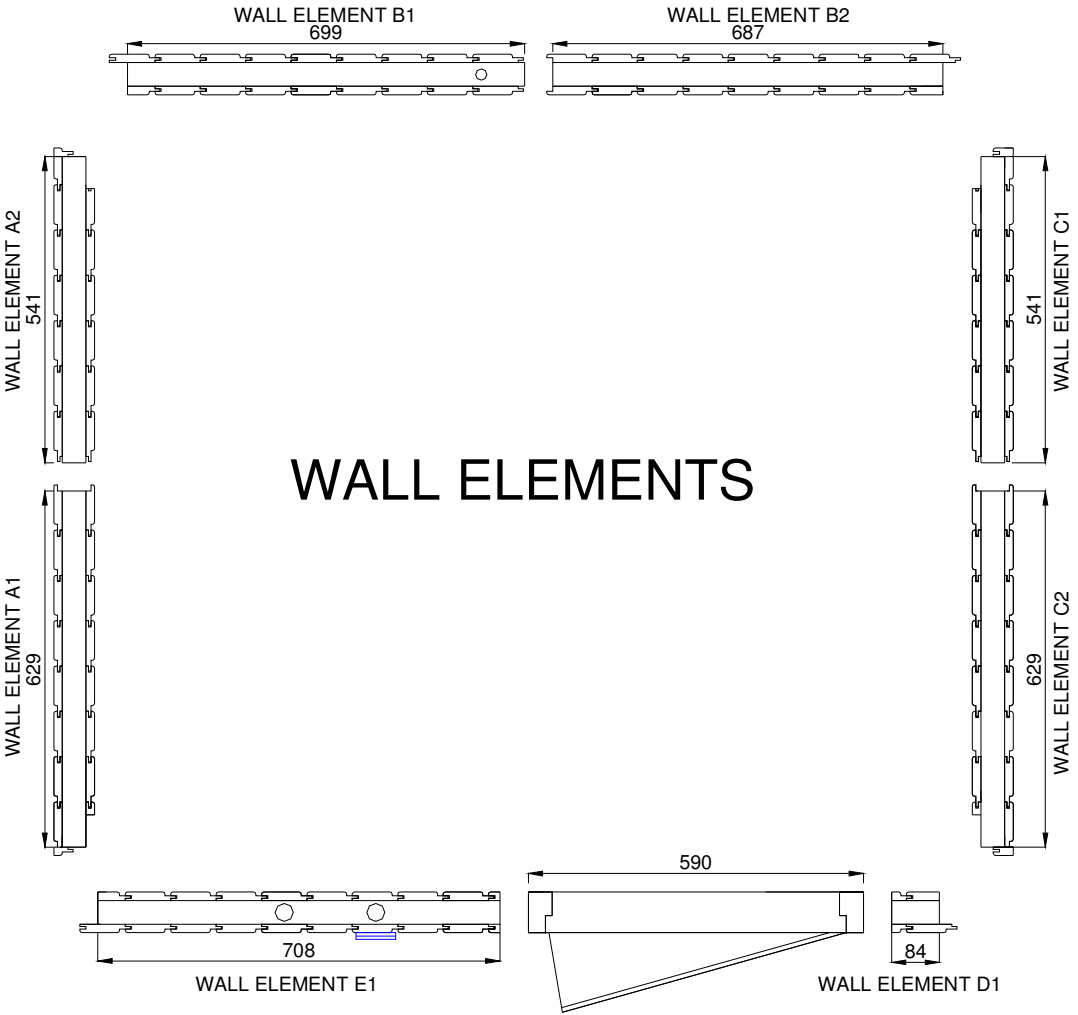

## WALL ELEMENTS

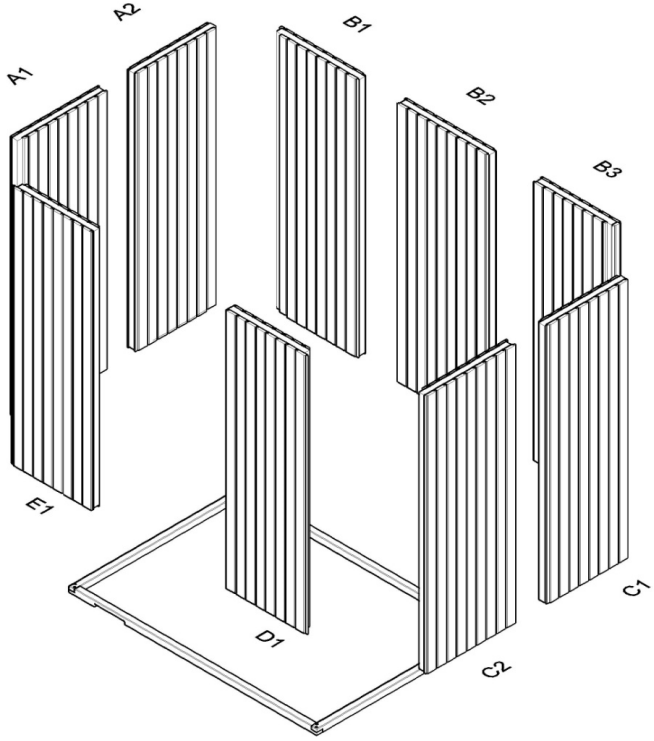

\* pictures are illustrative

INTERIOR (Wall to wall):

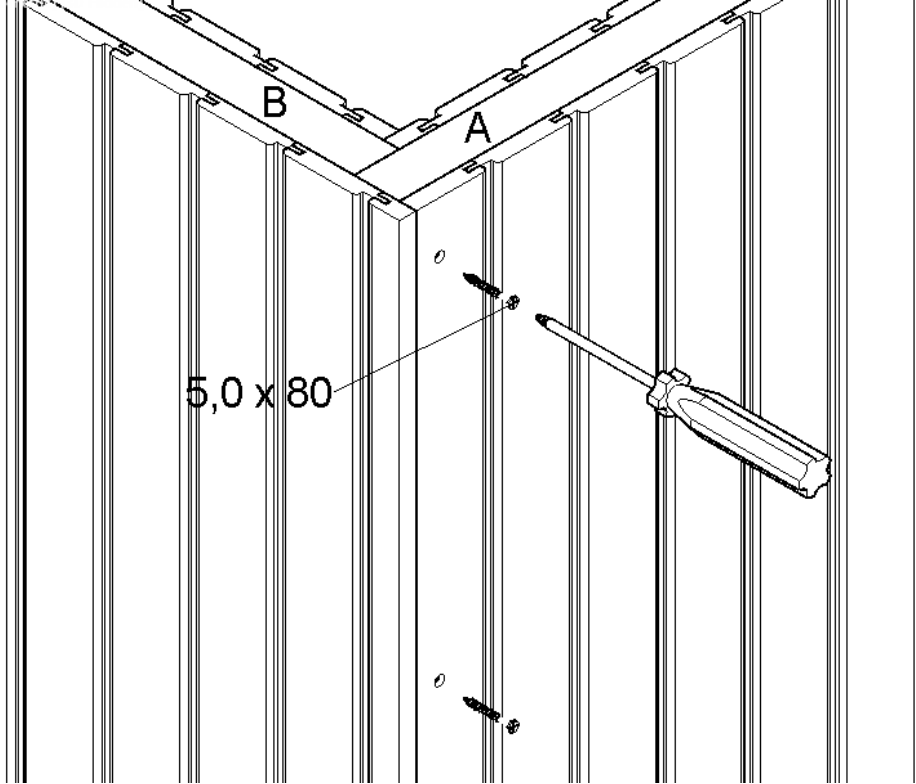

Corner:

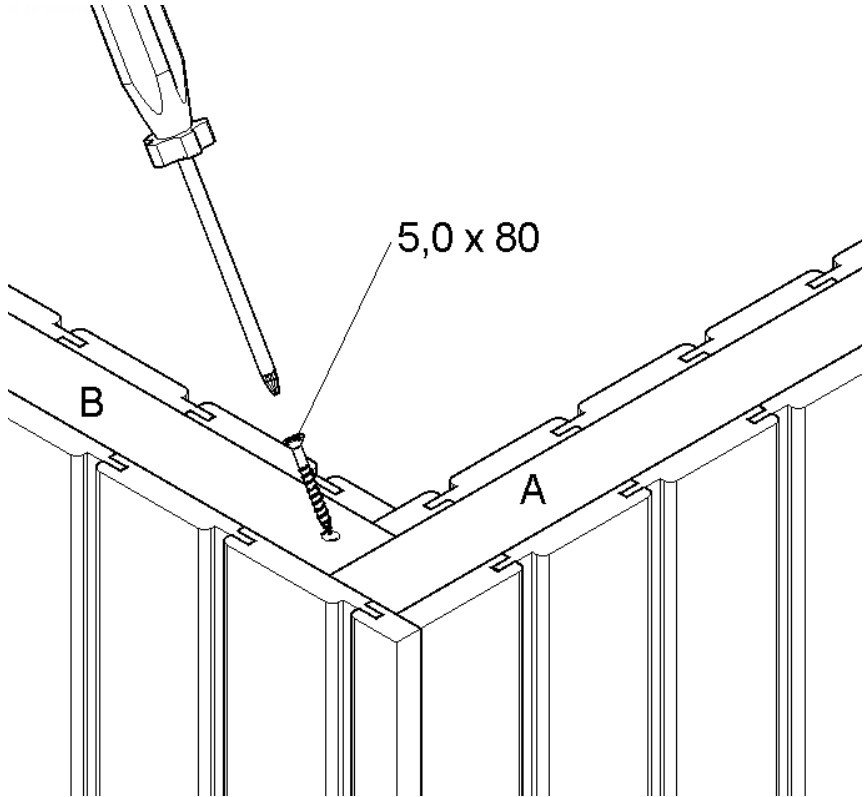

## 4. CEILING ELEMENTS

Make sure that the ceiling elements fit on the top of the wall elements. Check also, that the tongue and groove joints between ceiling elements are fastened properly to each other. You may need to lift the elements a little at the joints to make them slide together. Fix the ceiling elements with screws (5,0x80 mm).

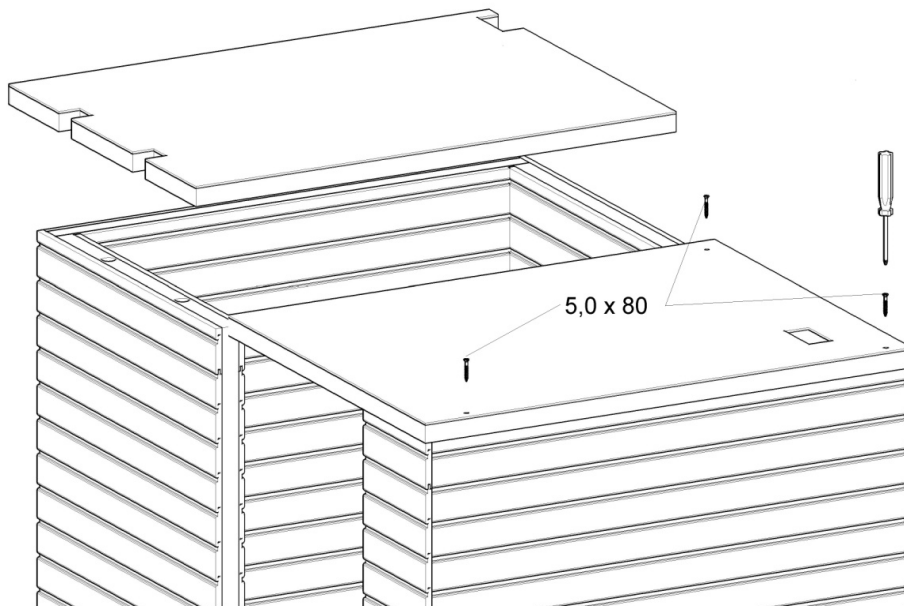
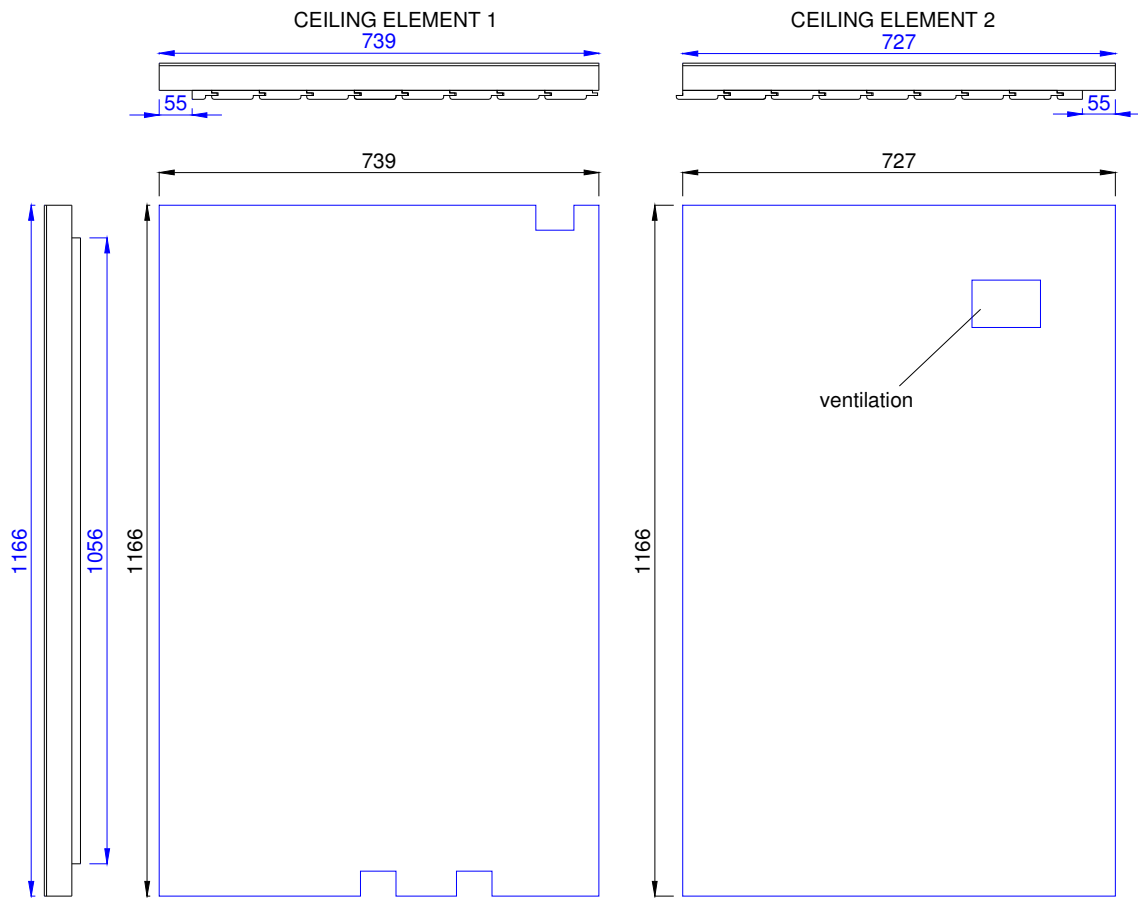

## 5. DOOR

Your sauna contains a high quality sauna door. Be careful when handling the door as the glass may break if it is hit with a sharp object. At no time should the edge of the glass touch a hard floor or wall surface. The door element is the last wall element. The door is fastened with screws (5,0x80 mm). Cover the exposed holes with wooden covers. The door always opens out.

If it is necessary to change hanging, move the top rail to the other end. Put the door on the floor, unscrew the upper plank's four screws, put the plank on the opposite side of the door and screw it up with the same four screws.

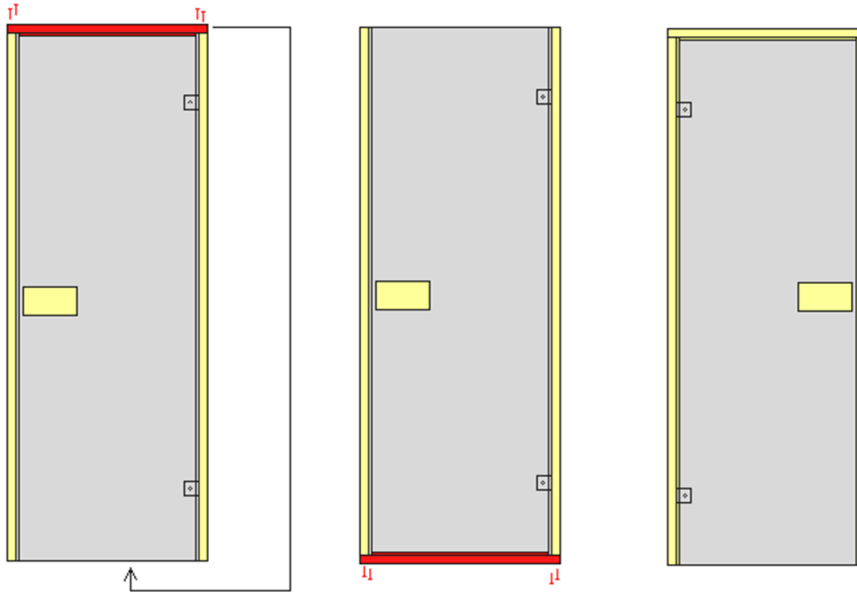

For making the door move easily, regulate the roller-lock when needed.

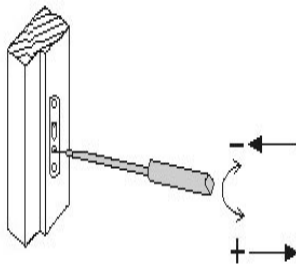

# 6. BENCHES

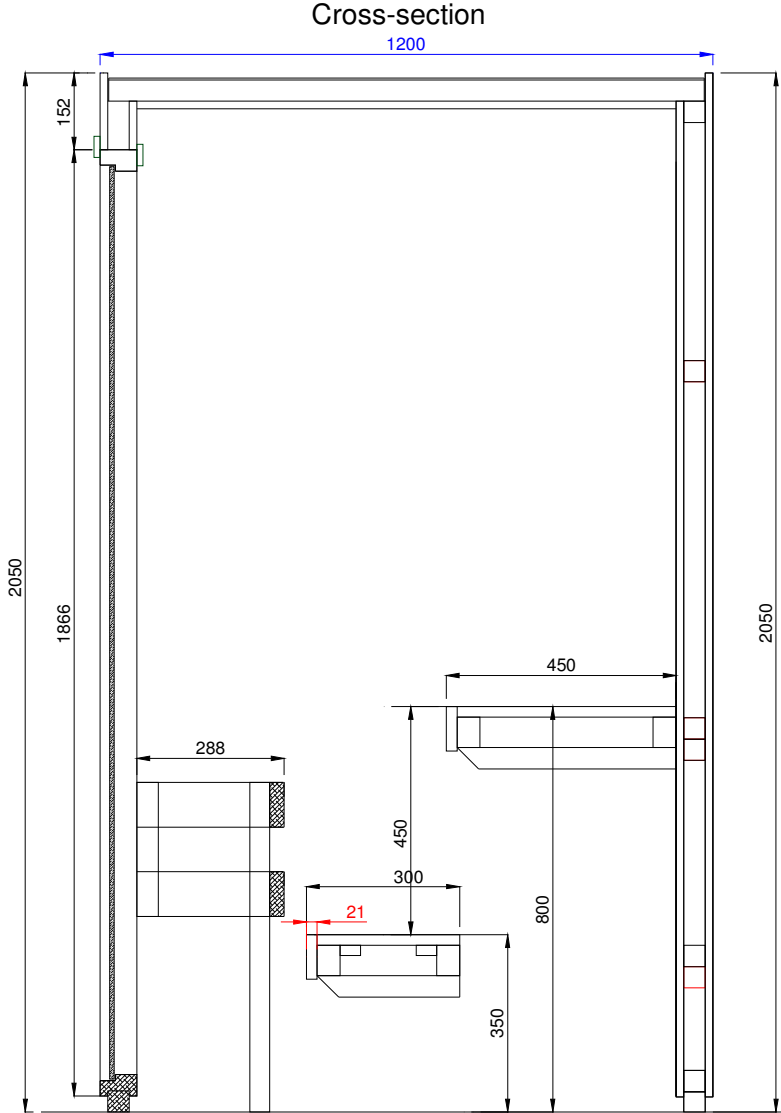

## 1. STEP : Fixing bench support

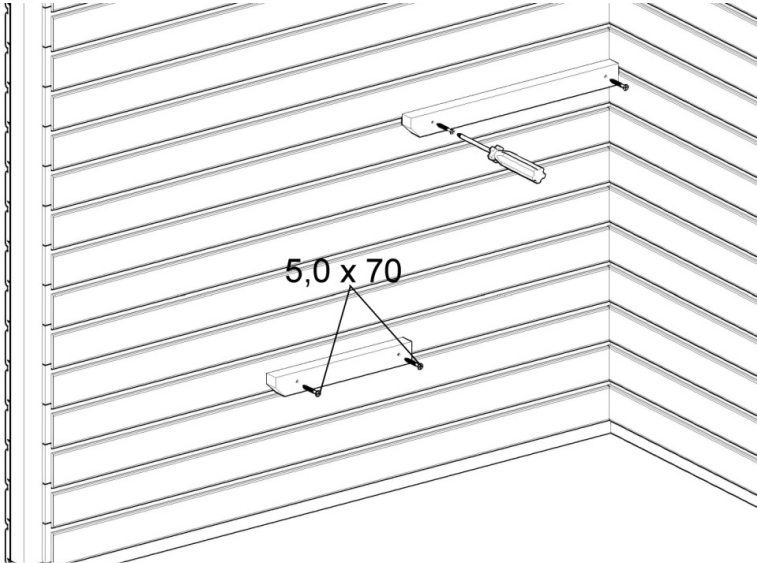





2. STEP : Fixing bench frames (screws 5,0x70 mm)

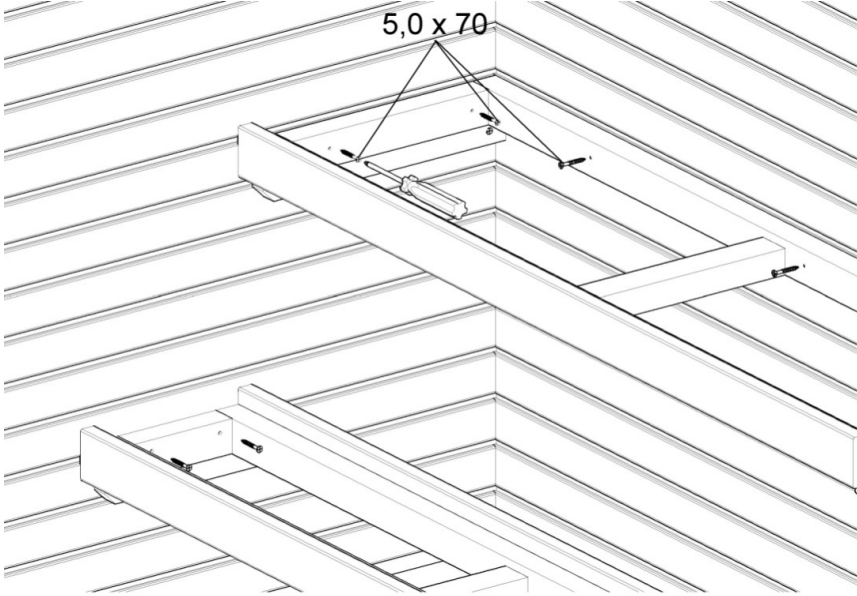

3. STEP : Fit in bench grid

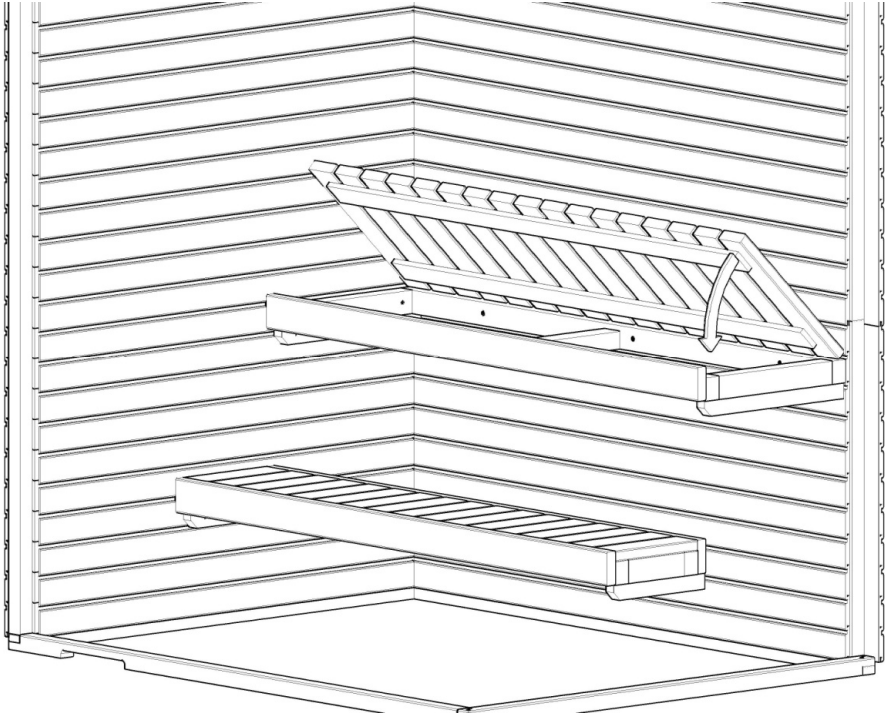

## 7. MOULDINGS

To give a finished appearance Your sauna install door moldings.  
Fasten them with nails.

	cross-cut	length		
Door moldings	12x42	1895	4 pcs.	
Door moldings	12x42	638	2 pcs.	
Corner moldings	12x42	2020	4 pcs.	

## 8. HEATER GUARD

Place the heater guard around the heater. Use screws (5,0x70 mm) for fastening the heater guard to the lower bench.

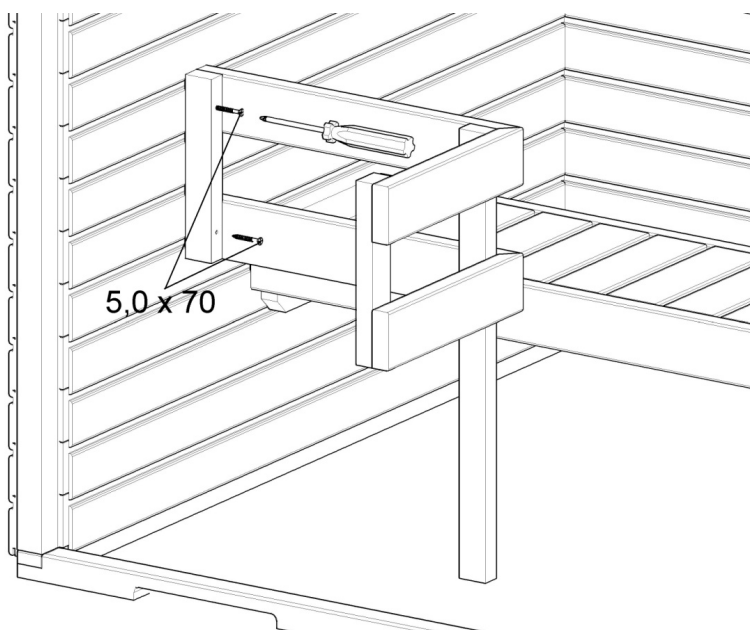

## 9. ELECTRICAL EQUIPMENT

Always use a certified electrician for any electrical work. Before installing heater and control unit follow the manufacturer directions. This will prevent injury to you and the product. You may need to install the control unit into a wall element. The sauna light should be installed under the bench. Use the silicone cable for the sauna light.

# 10. USER MANUAL FOR SAUNA

## 1. WALLS AND CEILING

Practice shows that panelling tends to dry out significantly faster in steam rooms where water is not thrown on heater stones than in steam rooms where air humidity is higher due to throwing water on heater stones. As to the cleaning and maintenance of walls and the ceiling, the same principles and methods apply as to the Bench. To protect walls and ceiling, use Tikkurila SUPI SAUNASUOJA.

After a sauna session leave the steam room to dry to remove excess moisture. To do this, keep the ventilation vent in the ceiling open for a couple of days.

## 2. BENCH

The Bench space should be divided so that each person has sitting room of approximately 60 cm (may also be less depending on the size of the room). In this way, it is more comfortable for people and the Bench is not overloaded either.

People should not wear wet swimsuits in the steam room since water dripping out of these significantly damages the sauna bench and its structure. To prolong the nice look of a bench, use mats for sitting. Also, this makes sitting on the hot sauna bench more comfortable.

Clean the sauna bench at least once a year with a special sauna cleaning agent, for instance Tikkurila SUPI SAUNAPESU. For harder stains that are difficult to remove with a cleaning agent fine sand paper can be used. After cleaning treat the Bench again with a bench protection agent, for instance Tikkurila SUPI LAUDESUOJA.

### **When cleaning a sauna, adhere to the following principles**

- Clean the Bench with an alkaline cleaning agent. Use a brush or an abrasive washing cloth. Do not forget to clean the bottom side of the Bench, edges of the Bench boards and the support structure of the Bench. After this, rinse wooden surfaces with water.
- To make cleaning even more efficient, use abrasive cleaning powders or disinfecting cleaning agents. These will also whiten the wooden surface. When using disinfecting cleaning agents, make sure that water and wood are cool. Before giving the surfaces a thorough rinse, leave the cleaning solution to sit for a while.
- Do not clean sauna walls with a hose applying great pressure because this may damage wall constructions.

Changes in the relative humidity level of the sauna air may cause wood to swell or shrink and amongst others have an impact on the moving of the sauna door. If the door does not stay closed, the lock sticks out too much or the door is not closing, adjust the lock by turning the adjuster screw above it clockwise or counter clockwise. The movement of a glass door is adjusted according to its type with the help of hinges and/or adjuster screws under the roller-lock. Before the first use of the steam room, read the heater manual.

### **Do not forget the following principles**

- Upon the first use sauna is to be heated under constant supervision and after that it needs to be thoroughly aired because various gases evaporate from sauna constructions and heater when the sauna is heated for the first time.
- The sauna is provided with air exchange fans that must be switched on during sauna and after sauna when the interior is drying.
- The ventilation valve must be open during sauna and after sauna, when the interior is drying.

- For the rest of the time, the ventilation valve must always be closed.
- The heater should be left switched on for about half an hour after finishing a sauna session.
- If the Bench steps are removable, lift them in horizontal position after sauna – this will facilitate drying.
- It is not permitted to dry laundry in the sauna, since moisture emitted from laundry darkens the wooden parts of the sauna. Also, hanging laundry to dry over the heater increases the risk of a fire.
- The stones of a heater should be reassembled at least once a year. Small and crumbling stones are removed and replaced by new and bigger ones. There are enough stones in a heater when heater bars are covered, but the pile of stones is not too high. A 10 cm layer of stones covering the bars is just right. It is important to avoid water coming into direct contact with the bars because it shortens their duration of use.
- The heater thermostat cannot function properly if heater stones have been assembled too densely or are too small.

As sauna panelling is imposed to high temperatures during heating, its moisture content is reduced and it tends to shrink. As a result, cracks may appear in panelling boards. It is normal that after the first year of using a sauna, panelling has surface cracks and partial transverse splits, provided that these do not cause boards to collapse.

Due to high temperatures present in a sauna, wood resin often oozes from the knots in panelling boards. This is a natural phenomenon and boards need to be replaced only if there is a danger of resin oozing on people.

Over time, wooden surfaces in the steam room, such as wall panelling, will darken. This is caused by heat emitted by the heater. Also, fine stone dust from heater stones rising up with the air flow may darken the wall surface near the heater.

The temperature tolerance limit of the steam room walls and ceiling is +135 °C. The highest temperature allowed in the heater room is about +125 °C. At temperatures higher than these there is a risk that fire break vents of air exchange devices launch and cut off ventilation in the apartment, presuming that the high temperature in the apartment is due to a fire.

## **WARNINGS!**

- Do not cover the sauna heater or place anything on or near the sauna heater.
- Do not touch the heater and heater stones when heater works or after work.
- Do not throw cold water on the hot heater stones or against the window, they may shatter in an instant. Use on heater only clean and hot water.
- Do not install sauna instruments (thermometers etc.) in the area of the heater
- Do not damage or use damaged silicone coated wires.
- Do not use any polyurethane, paint or wood sealer for coating the sauna wood surfaces.
- Do not close sauna ventilation openings
- Do not use sauna under the influence of alcohol, drugs or when You are sick.