

Polhus

2518-Mille-2

Instructions for assembly, maintenance and safe use.

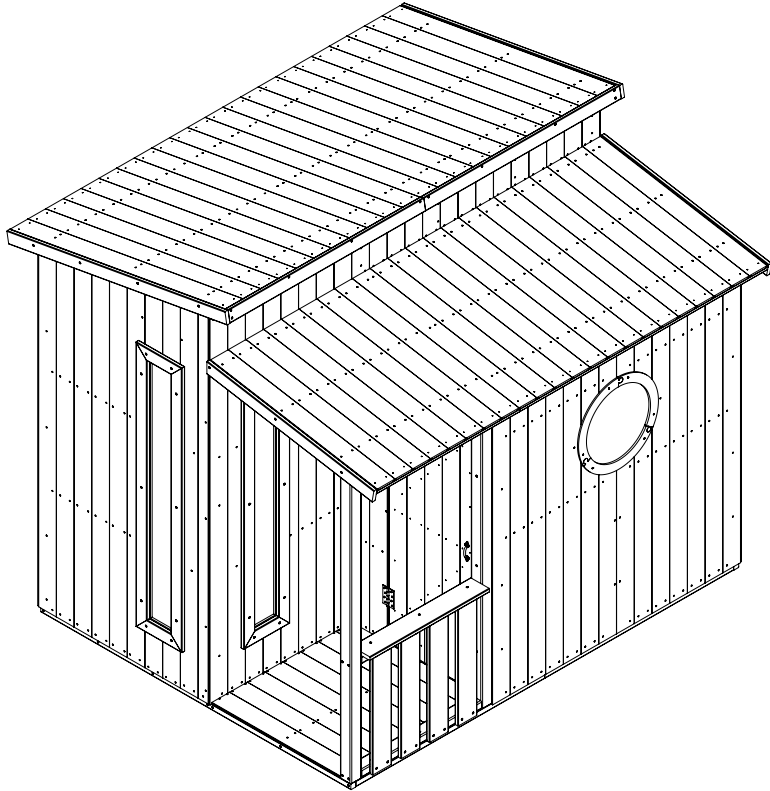

WARNING!

- THIS PRODUCT IS NOT SUITABLE FOR CHILDREN UNDER 36 MONTHS. CONTAINS SMALL PARTS (CHOKING HAZARDS)
- EQUIPMENT CAN BECOME SLIPPY WHEN WET/ICY/DIRTY, EXTRA CARE MUST BE TAKEN IF USED IN THESE CONDITIONS
- ONLY FOR DOMESTIC USE. FOR OUTDOOR USE
- PRODUCT MUST BE ASSEMBLED BY AN ADULT(S) BEFORE USE
- ADULT SUPERVISION IS REQUIRED
- CHILDREN MUST NOT USE THE EQUIPMENT UNTIL PROPERLY INSTALLED
- REMOVE ALL PACKAGING BEFORE USE
- RETAIN MANUAL FOR FUTURE REFERENCE
- MAX USER WEIGHT: 50KG



ADVISORY SECTION

EN

TO ENSURE THE SAFETY OF YOURSELF, THE INSTALLER AND CHILDREN, IT IS IMPORTANT THAT THE INSTRUCTION MANUAL IS READ FULLY AND UNDERSTOOD BEFORE COMMENCING INSTALLATION AND PLAY!

SAFETY CONSIDERATIONS

- This product contains small parts, and is therefore not suitable for children under 36 months (3 years)
- Domestic outdoor use only, and must be installed by an adult! As a domestic product, this should not be installed in a school, public house garden or communal play area etc.
- Install on a flat surface (less than a 2% slope), this will reduce risk of instability and injury.
- Product must be installed on suitable surfaces (i.e. do not install on concrete, slabs, asphalt, tarmac, or any hard/broken surface)
- Product must be installed in a clear safe area, 2m away from obstruction or structures. i.e. fences, garages, houses, trees/overhanging branches, laundry lines or electrical wires etc.
- Any changes to this toy e.g. changing or adding an accessory, must be done in accordance with our instructions. Failure to do this will render your guarantee null and void and may make your product unsafe
- If possible orientate/position the product so plastic components (Slides, swings, etc.) have reduced sun exposure

The safety of children using this equipment is your responsibility, therefore it is advised that children be supervised at all times. Do not allow children to wear clothing that will cause a hazard, such as loose clothing (toggles/tassels and loose hair). Care must also be taken to ensure the product is not misused, i.e. used in a manner that is outside the intended purpose, do not allow children to climb onto areas that were not designed to be climbed on.

TIMBER AND TREATMENT INFORMATION

All products are manufactured utilising premium quality timber. Strict timber selection processes ensure that all timber is selected, cut and planed to correct specifications. Timber however is a natural product material, and will therefore experience changes in both appearance and composition during its life cycle. This means that it may;

- Develop openings in the structure of wood following the grain, openings include (gaps, slits, apertures, cracks and also splits). These gaps are caused by the difference in moisture content on the internal and external surfaces of the timber. This is expected during drier and wetter seasons, this is not a cause for concern and will not affect structural integrity, life or guarantee of the product.
- Warp and distort in overall shape. Any distortion or warping of the timber will only be slight, and will not affect the overall enjoyment or structural integrity of the equipment.
- Fade in colour as the timber reacts to exposure to UV light. The timber will react with the sunlight, and fade over time, treatment of the wood with a proprietary product is recommended on an annual basis.

Timber is supplied untreated, for you to decorate and finish to your own taste and style. We strongly advise that you treat your timber product as soon as you construct it! and continue to treat it regularly to strengthen it against varying weather conditions. If left untreated, your product will begin to deteriorate more rapidly.

If constructing and treating the timber during wetter seasons, check the weather forecast and construct during a dry spell. Make sure that the product is dry before you begin treatment. Same applies for the maintenance; so that it is undertaken in dry weather.

Once you've applied your wood treatment, you need to make sure it's properly maintained. Follow the manufactures guidelines; most treatments need to be reapplied every three to five years.

ROUTINE MAINTENANCE

-It is advised that periodic maintenance checks are needed on the equipment, at the beginning of the season and monthly thereafter. Items to check include; Main parts, fixings, bolts, anchors and fabrics. Failure to perform periodic checks may result in injury.

-Regularly check fixing tightness and re-tighten if necessary, keep joints lubricated and replace any missing fixing/ edge covers.

-Any attachments, such as swings and ropes, must be regularly checked for evidence of degradation or deterioration. Replace any parts that show signs of this.

-During long periods of non-use, equipment is recommended to be dismantled and stored in a dry cool place, such as garages or sheds. This will prolong the life of the product during adverse weather conditions, this does not include timber.

-Remember to keep this manual in a safe location for reference and future use.



WARNHINWEIS

DE

ZUR GEWÄHRLEISTUNG IHRER EIGENEN SICHERHEIT UND DER SICHERHEIT DES MONTEURS UND IHRER KINDER IST ES WICHTIG, VOR MONTAGE- UND SPIELBEGINN DIE BEDIENUNGSANLEITUNG VOLLSTÄNDIG DURCHZULESEN UND ZU VERSTEHEN!

SICHERHEITSHINWEISE

- Dieses Produkt enthält Kleinteile und ist deshalb nicht für Kinder unter 36 Monaten (3 Jahren) geeignet.
- Nur für den Hausgebrauch im Freien. Montage nur durch Erwachsene! Als Produkt für den Hausgebrauch darf dieses Gerät nicht in Schulen, in Gärten von Gaststätten oder auf öffentlichen Spielplätzen aufgestellt werden.
- Auf einer ebenen Fläche montieren (weniger als 2 % Neigung). Dies reduziert die Gefahr von Instabilität und Verletzungen.
- Das Produkt auf einem geeigneten Untergrund aufstellen (d. h. nicht auf Beton, Steinplatten, Asphalt oder harten/gebrochenen Untergründen aufstellen)
- Das Produkt an einer freien, sicheren Stelle mit einem Abstand von 2 m zu Hindernissen oder Bauwerken wie Zäunen, Garagen, Häusern, Bäumen/ausladenden Ästen, Wäscheleinen oder elektrischen Leitungen usw. aufstellen.
- Jegliche Änderungen an diesem Spielzeug, z. B. das Ändern oder Hinzufügen eines Zubehörs muss gemäß unseren Anweisungen erfolgen. Andernfalls wird Ihre Garantie null und nichtig und Ihr Produkt kann unsicher werden
- Richten Sie das Produkt nach Möglichkeit so aus, dass Kunststoffkomponenten (Rutschen, Schaukeln usw.) einer geringeren Sonneneinstrahlung ausgesetzt sind

Da Sie für die Sicherheit der Kinder bei der Verwendung dieses Produkts verantwortlich sind, sollten die Kinder während der gesamten Nutzung beaufsichtigt werden. Sorgen Sie dafür, dass die Kinder keine Kleidung tragen, welche Gefahren verursacht, z. B. lose Kleidung (Ringe/Quasten und loses Haar). Außerdem ist sicherzustellen, dass das Produkt nicht zweckentfremdet wird, d. h. außerhalb des Verwendungszwecks genutzt wird. Lassen Sie beispielsweise nicht zu, dass Kinder auf Bereiche klettern, die dafür nicht vorgesehen sind.

INFORMATIONEN ZU HOLZ UND BEHANDLUNG

Alle Produkte werden aus hochwertigem Holz hergestellt. Strenge Holzauswahlprozesse stellen sicher, dass alle Hölzer gemäß den korrekten Spezifikationen ausgewählt, geschnitten und gehobelt werden. Holz ist jedoch ein Naturprodukt und wird daher im Laufe seines Lebenszyklus Veränderungen in Aussehen und Zusammensetzung erfahren. Dies bedeutet, dass es möglicherweise;

- Spaltbildung in der Holzkonstruktion in Holzfaserrichtung (einschließlich Spalte, Schlitze, Öffnungen, Sprünge und auch Risse). Diese Spalte werden durch Unterschiede des Feuchtegehalts der Innen- und Außenflächen des Holzes verursacht. Diese an sich unbedenkliche Entwicklung tritt in trockeneren und feuchteren Jahreszeiten auf und beeinträchtigt in keiner Weise die strukturelle Unversehrtheit, Lebensdauer und Gewährleistung des Produkts.
- Verwerfung und Deformation der Gesamtform. Deformationen oder Verwerfungen des Holzes sind nur geringfügig und schmälern nicht den Spielspaß oder die strukturelle Unversehrtheit des Geräts.
- Verblasen der Farbe aufgrund von UV-Strahlung. Das Holz reagiert auf Sonnenlicht und verblasst mit der Zeit. Es wird empfohlen, das Holz jährlich mit einem Markenprodukt zu behandeln.

Das Holz wird unbehandelt geliefert, damit Sie es nach Ihrem eigenen Geschmack und Stil dekorieren und veredeln können. Wir raten Ihnen dringend, Ihr Holzprodukt gleich nach dem Bau zu behandeln! und behandeln Sie es weiterhin regelmäßig, um es gegen wechselnde Wetterbedingungen zu stärken. Wenn es unbehandelt bleibt, beginnt sich Ihr Produkt schneller zu verschlechtern.

Wenn Sie das Holz während der feuchteren Jahreszeiten bauen und behandeln, überprüfen Sie die Wettervorhersage und bauen Sie während einer Trockenperiode. Stellen Sie sicher, dass das Produkt trocken ist, bevor Sie mit der Behandlung beginnen. Gleiches gilt für die Wartung; damit es bei trockenem Wetter durchgeführt wird.

Nachdem Sie Ihre Holzbehandlung aufgetragen haben, müssen Sie sicherstellen, dass sie ordnungsgemäß gepflegt wird. Befolgen Sie die Richtlinien des Herstellers; die meisten Behandlungen müssen alle drei bis fünf Jahre wiederholt werden.

REGELMÄSSIGE WARTUNG

-Wie bereits erwähnt, wird empfohlen, das Gerät jeweils am Anfang der Spielsaison und dann monatlich zu warten und zu kontrollieren. Zu prüfende Teile: Hauptteile, Befestigungen, Schrauben, Anker und Gewebe. Die Unterlassung regelmäßiger Kontrollen kann zu Verletzungen führen.

-Überprüfen Sie regelmäßig die Festigkeit der Befestigungen und ziehen Sie sie gegebenenfalls nach, halten Sie die Verbindungen geschmiert und ersetzen Sie fehlende Befestigungen/Kantenabdeckungen.

-Jegliches Zubehör wie Schaukeln und Seile muss regelmäßig auf Verschleiß und Alterung geprüft werden. Jegliche Teile ersetzen, die Anzeichen für Verschleiß und Alterung aufweisen.

-Bei längerer Nichtbenutzung wird empfohlen, das Gerät zu demontieren und an einer kühlen, trockenen Stelle wie z. B. in einer Garage oder in einem Schuppen einzulagern. Dadurch wird die Lebensdauer des Produkts bei ungünstigen Witterungsverhältnissen verlängert. Dies bezieht sich nicht auf Holz.

-Diese Bedienungsanleitung als Referenz und für die zukünftige Benutzung an einer sicheren Stelle aufbewahren.



OM DE VEILIGHEID VAN UZELF, DE INSTALLATEUR EN KINDEREN TE GARANDEREN, IS HET BELANGRIJK DAT DE HANDLEIDING VOLLEDIG WORDT GELEZEN EN BEGREPEN ALVORENS TE BEGINNEN MET INSTALLEREN EN SPELEN!

VEILIGHEIDSPUNTEN

- Dit product bevat kleine onderdelen en is daarom niet geschikt voor kinderen jonger dan 36 maanden (3 jaar)
- Alleen voor huishoudelijk gebruik buitenshuis, moet door een volwassene worden geïnstalleerd! Als huishoudelijk product mag dit product niet in een school, openbare tuin of gemeenschappelijke speelruimte etc. worden geïnstalleerd.
- Installeren op een vlakke ondergrond (minder dan 2% helling), dit vermindert het risico op instabiliteit en letsel.
- Het product dient op geschikte oppervlakken te worden geïnstalleerd (d.w.z. niet installeren op beton, platen, asfalt, asfalt of een hard/gebroken oppervlakken)
- Het product moet in een duidelijke veilige ruimte worden geïnstalleerd, op 2 meter afstand van obstakels of constructies. d.w.z. hekken, garages, huizen, bomen/overhangende takken, waslijnen of elektriciteitsdraden etc.
- Eventuele wijzigingen aan dit speelgoed, b.v. het wijzigen of toevoegen van een accessoire, dient te gebeuren in overeenstemming met onze instructies. Als u dit niet doet, wordt uw garantie ongeldig en kan uw product onveilig worden
- Richt/plaats het product indien mogelijk zo dat plastic onderdelen (glijbanen, schommels, enz.) minder aan de zon worden blootgesteld

De veiligheid van kinderen die deze apparatuur gebruiken is uw verantwoordelijkheid; daarom wordt geadviseerd om te allen tijde toezicht op kinderen te houden. Zorg ervoor dat kinderen geen kleding dragen die gevaar kan opleveren, zoals losse kleding (houtje-touwtje sluiting, kwastjes en los haar). Let er ook op dat het product niet wordt misbruikt, d.w.z. dat het wordt gebruikt op een manier die buiten het beoogde doel ligt, en dat kinderen niet op delen kunnen klimmen die niet zijn ontworpen om op te klimmen.

HOUT- EN BEHANDELINGSINFORMATIE

Alle producten worden vervaardigd met behulp van hoogwaardig hout. Strenge houtselectieprocessen zorgen ervoor dat al het hout wordt geselecteerd, gekapt en geschaafd volgens de juiste specificaties. Hout is echter een natuurlijk productmateriaal en zal daarom tijdens zijn levenscyclus veranderingen ondergaan in zowel uiterlijk als samenstelling. Dit betekent dat het mag;

- Het ontstaan van openingen in de structuur van het hout die de nerf volgen (zoals gaten, spleten, openingen, scheuren en barsten). Deze openingen worden veroorzaakt door het verschil in vochtgehalte op de binnen- en buitenoppervlakken van het hout. Dit is te verwachten tijdens drogere en nattere seizoenen; het is geen reden tot bezorgdheid en heeft geen invloed op de structurele integriteit, levensduur of garantie van het product.
- Vervorming van de algemene vorm. Het vervormen of kromtrekken van het hout zal slechts minimaal zijn en zal het gehele gebruiksplezier of de structurele integriteit van de apparatuur niet beïnvloeden.
- Verbleken terwijl het hout reageert op blootstelling aan UV-licht. Het hout reageert op het zonlicht en vervaagt in de loop van de tijd; een jaarlijkse behandeling van het hout met een speciaal product wordt aanbevolen.

Hout wordt onbehandeld geleverd, zodat je het naar eigen smaak en stijl kunt decoreren en afwerken. We raden u ten eerste aan om uw houtproduct te behandelen zodra u het construeert! en blijf het regelmatig behandelen om het te versterken tegen wisselende weersomstandigheden. Indien onbehandeld, zal uw product sneller beginnen te verslechteren.

Als u het hout construeert en behandelt tijdens nattere seizoenen, controleer dan de weersvoorspelling en construeer tijdens een droge periode. Zorg ervoor dat het product droog is voordat u met de behandeling begint. Hetzelfde geldt voor het onderhoud; zodat het bij droog weer wordt uitgevoerd.

Nadat u uw houtbehandeling heeft toegepast, moet u ervoor zorgen dat deze goed wordt onderhouden. Volg de richtlijnen van de fabrikant; de meeste behandelingen moeten elke drie tot vijf jaar opnieuw worden toegepast.

PERIODIEK ONDERHOUD

-Zoals eerder vermeld, is het raadzaam om aan het begin van het seizoen en daarna maandelijks onderhoud aan de apparatuur uit te voeren. Te controleren items zijn onder meer de hoofdonderdelen, bevestigingen, bouten, ankers en stoffen. Het niet uitvoeren van periodieke controles kan leiden tot letsel.

-Controleer regelmatig of de bevestiging goed vastzit en draai indien nodig opnieuw aan, houd verbindingen gesmeerd en vervang ontbrekende bevestigings-/randafdekkingen.

-Alle onderdelen, zoals schommels en touwen, dienen regelmatig te worden gecontroleerd op tekenen van slijtage of beschadiging. Vervang alle onderdelen die hier tekenen van vertonen.

-Bij lange perioden van niet-gebruik wordt aanbevolen om apparatuur te demonteren en op een droge, koele plaats te bewaren, zoals in een garage of schuur. Dit verlengt de levensduur van het product tijdens ongunstige weersomstandigheden, dit geldt niet voor hout.

-Bewaar deze handleiding op een veilige plaats voor referentie en toekomstig gebruik.



RECOMMANDATION

FR

POUR ASSURER LA SECURITE DE VOS ENFANTS, DE LA PERSONNE CHARGEE DE L'INSTALLATION ET DE VOUS-MÊME, LE MANUEL D'EMPLOI DOIT ÊTRE LU INTEGRALEMENT ET COMPRIS AVANT DE COMMENCER L'INSTALLATION ET L'UTILISATION!

SECURITE

- Ce produit contient des petites pièces et n'est donc pas adapté aux enfants de moins de 36 mois (3 ans)
- Le produit est destiné exclusivement à un usage privé dans les espaces extérieurs, et doit être installé par un adulte ! En tant que produit à usage privé, il ne doit pas être installé dans une école, un jardin public, une aire de jeux communale, etc.
- Installer le produit sur une surface plane (inclinaison inférieure à 2 %), afin de minimiser les risques d'instabilité et de blessures.
- Le produit doit être installé sur une surface adaptée (ne pas l'installer sur du béton, des dalles, des surfaces goudronnées ou toute autre surface dure)
- Le produit doit être installé dans une zone sûre et dégagée, à 2 m de toute obstruction ou structure, c'est-à-dire des clôtures, garages, maisons, arbres/branches basses, fils à linge ou câbles électriques, etc.
- Toute modification apportée à ce jouet, par ex. changer ou ajouter un accessoire, doit être fait conformément à nos instructions. Le non-respect de cette consigne rendra votre garantie nulle et non avenue et peut rendre votre produit dangereux.
- Si possible, orientez/positionnez le produit de manière à ce que les composants en plastique (toboggans, balançoires, etc.) soient moins exposés au soleil

Vous êtes responsable de la sécurité des enfants utilisant ce produit. Nous vous recommandons donc de surveiller les enfants à tout instant. Ne permettez pas aux enfants de porter des vêtements qui peuvent occasionner des risques, tels des vêtements amples (pompons, cheveux longs détachés). Veillez également à assurer que le produit n'est pas utilisé de manière abusive : il doit être utilisé de manière conforme. Ne permettez pas aux enfants de grimper sur les éléments qui n'ont pas été conçus à cet effet.

INFORMATIONS SUR LE BOIS ET LE TRAITEMENT

Tous les produits sont fabriqués à partir de bois de première qualité. Des processus stricts de sélection du bois garantissent que tout le bois est sélectionné, coupé et raboté selon les spécifications correctes. Cependant, le bois est un matériau naturel et subira donc des changements d'apparence et de composition au cours de son cycle de vie. Cela signifie qu'il peut;

- développer des fissures dans la structure du bois en suivant le grain (fissures, craquelures, trous et fentes). Ces fissures sont occasionnées par les différences de teneur d'humidité à la surface et à l'intérieur du bois. Elles évoluent au fil des saisons sèches et humides et ne constituent pas une raison d'inquiétude, puisqu'elles ne nuisent pas à l'intégrité structurelle, à la longévité ou aux garanties accordées sur le produit.
- travailler au niveau de la forme globale. Le travail et les torsions du bois seront mineures et ne nuisent pas au plaisir des enfants ou à l'intégrité structurelle du produit.
- se décolorer suite à l'exposition du bois aux UV. Le bois réagit à la lumière du soleil et se décolore au fil du temps. Nous recommandons d'appliquer une fois par un traitement pour le bois.

Le bois est fourni non traité, à décorer et à finir selon vos goûts et votre style. Nous vous conseillons vivement de traiter votre produit bois dès sa construction ! et continuez à le traiter régulièrement pour le renforcer contre les conditions météorologiques variables. S'il n'est pas traité, votre produit commencera à se détériorer plus rapidement.

Si vous construisez et traitez le bois pendant les saisons plus humides, vérifiez les prévisions météorologiques et construisez pendant une période sèche. Assurez-vous que le produit est sec avant de commencer le traitement. Il en va de même pour l'entretien ; afin qu'il soit entrepris par temps sec.

Une fois que vous avez appliqué votre traitement du bois, vous devez vous assurer qu'il est bien entretenu. Suivez les directives du fabricant ; la plupart des traitements doivent être réappliqués tous les trois à cinq ans.

ENTRETIEN COURANT

-Comme indiqué précédemment, nous recommandons d'effectuer des contrôles périodiques du produit au début de la saison d'utilisation, puis tous les mois. Parmi les points à contrôler figurent les éléments principaux, les assemblages, les boulons, ancrages et les tissus. En absence de contrôler périodiques, des blessures sont possibles.

-Vérifiez régulièrement l'étanchéité des fixations et resserrez si nécessaire, maintenez les joints lubrifiés et remplacez les fixations/rebords manquants.

-Tous les accessoires tels que les balançoires et les cordes doivent faire l'objet de contrôles réguliers pour déceler les dégradations ou détériorations. Remplacez tous les éléments qui présentent des signes d'usure ou de détérioration.

-Nous recommandons de démonter le produit et de le ranger à un endroit sec et frais, par ex. un garage ou un abri de jardin, s'il n'est pas utilisé pendant une période prolongée. Cela permettra de prolonger la durée de vie du produit pendant les périodes d'intempéries. Ceci ne concerne pas la structure en bois.

-Gardez le présent manuel en lieu sûr afin de pouvoir vous y reporter le cas échéant.



SEZIONE AVVISI

IT

PER GARANTIRE LA PROPRIA SICUREZZA, LA SICUREZZA DELL'INSTALLATORE E DEI BAMBINI, È IMPORTANTE CHE IL MANUALE DI ISTRUZIONI SIA LETTO E COMPRESO INTERAMENTE PRIMA DI INIZIARE IL MONTAGGIO E L'USO DEL PRODOTTO!

CONSIDERAZIONI SULLA SICUREZZA

- Il presente prodotto contiene delle piccole parti e quindi non è adatto per bambini di età inferiore ai 36 mesi (3 anni)
- Solo per uso domestico all'aperto e deve essere installato da un adulto! Essendo un prodotto domestico, esso non deve essere installato in una scuola, in un giardino pubblico o in un parco giochi comunale, ecc.
- Installare il prodotto su una superficie piana (meno del 2% di pendenza), ciò ridurrà il rischio di instabilità e lesioni.
- Il prodotto deve essere installato su superfici idonee (ad es. non su cemento, tavole, asfalto, catrame o qualsiasi superficie dura/rotta)
- Il prodotto deve essere installato in un'area libera e sicura, a 2 m di distanza da ostacoli o strutture, ad es. recinzioni, garage, case, alberi/rami sporgenti, fili per il bucato o cavi elettrici ecc.
- Eventuali modifiche a questo giocattolo, ad es. la modifica o l'aggiunta di un accessorio, deve essere eseguita secondo le nostre istruzioni. In caso contrario, la garanzia verrà annullata e il prodotto potrebbe non essere sicuro
- Se possibile orientare/posizionare il prodotto in modo che i componenti in plastica (scivoli, altalene, ecc.) abbiano una ridotta esposizione al sole

La sicurezza dei bambini che utilizzano questa attrezzatura è responsabilità dell'utente, pertanto, si consiglia di sorvegliare i bambini in ogni momento. Non permettere ai bambini di indossare indumenti che possano causare un pericolo, ad es. indumenti larghi (alamari/nappe e capelli sciolti). È inoltre necessario prestare attenzione per garantire che il prodotto non venga utilizzato in maniera impropria, ovvero utilizzato in un modo al di fuori dello scopo previsto, non consentire ai bambini di arrampicarsi su aree non progettate per essere arrampicate.

INFORMAZIONI SUL LEGNO E SUL TRATTAMENTO

Tutti i prodotti sono realizzati utilizzando legname di prima qualità. Processi rigorosi di selezione del legname assicurano che tutto il legname sia selezionato, tagliato e piallato secondo le specifiche corrette. Il legno, tuttavia, è un materiale prodotto naturale e pertanto subirà cambiamenti sia nell'aspetto che nella composizione durante il suo ciclo di vita. Ciò significa che potrebbe;

- Sviluppare aperture nella sua struttura seguendo la venatura, queste le aperture comprendono interstizi, fessure, aperture, crepe e anche spaccature. Queste aperture sono causate dalla differenza del contenuto di umidità sulle superfici interne ed esterne del legno. Ciò potrebbe manifestarsi durante le stagioni più secche e umide e non rappresenta alcun motivo di preoccupazione e non influirà sull'integrità strutturale, sulla durata o sulla garanzia del prodotto.
- Deformarsi e deformarsi nella sua forma generale. Qualsiasi distorsione o deformazione del legno sarà solo lieve e non influirà sul godimento complessivo o sull'integrità strutturale del prodotto.
- Presentare uno sbiadimento del colore come reazione del legno all'esposizione ai raggi UV. Il legno reagirà con la luce solare e sbiadirà nel tempo, si consiglia quindi un trattamento del legno con un prodotto proprietario su base annuale.

Il legname viene fornito non trattato, da decorare e rifinire secondo il proprio gusto e stile. Ti consigliamo vivamente di trattare il tuo prodotto in legno non appena lo costruisci! e continua a trattarlo regolarmente per rafforzarlo contro le condizioni meteorologiche variabili. Se non trattato, il prodotto inizierà a deteriorarsi più rapidamente.

Se si costruisce e si tratta il legname durante le stagioni più umide, controllare le previsioni del tempo e costruire durante un periodo di siccità. Assicurarsi che il prodotto sia asciutto prima di iniziare il trattamento. Lo stesso vale per la manutenzione; in modo che sia intrapreso con tempo asciutto.

Dopo aver applicato il trattamento del legno, devi assicurarti che sia adeguatamente mantenuto. Seguire le linee guida del produttore; la maggior parte dei trattamenti deve essere riapplicata ogni tre o cinque anni.

MANUTENZIONE ORDINARIA

-Come già accennato in precedenza, si consiglia di effettuare controlli di manutenzione periodici sul prodotto, all'inizio della stagione e in seguito mensilmente. Gli elementi da controllare includono: elementi principali, fissaggi, bulloni, ancore e tessuti. La mancata esecuzione dei controlli periodici può causare lesioni.

-Controllare regolarmente la tenuta dei fissaggi ed eventualmente riserrare, mantenere lubrificati i giunti e sostituire eventuali fissaggi/coperchi bordi mancanti.

-Eventuali accessori, quali altalene e funi, devono essere controllati regolarmente per rilevare eventuali segni di deterioramento. Sostituire tutte le parti che mostrano tali segni.

-Durante i lunghi periodi di inutilizzo, si consiglia di smontare e riporre le apparecchiature in un luogo fresco e asciutto, ad es. garage o capannoni. Ciò prolungherà la vita del prodotto in condizioni meteorologiche avverse, escluso il legno.

-Sempre conservare questo manuale in un luogo sicuro per riferimento e uso futuro.



ADVERTENCIAS

ES

PARA GARANTIZAR SU SEGURIDAD, LA DEL INSTALADOR Y LA DE LOS NIÑOS, ES IMPORTANTE LEER EL MANUAL DE INSTRUCCIONES CON PRECAUCIÓN Y ENTENDERLO COMPLETAMENTE ANTES DE EMPEZAR CON LA INSTALACIÓN Y EL JUEGO.

CONSIDERACIONES DE SEGURIDAD

- Este producto contiene piezas pequeñas, por lo que no es apto para niños menores de 36 meses (3 años).
- Solo para uso doméstico en exteriores. Debe ser instalado por un adulto. Por ser un producto para uso doméstico, no debería instalarse en un colegio, jardín o zona de juegos públicos, etc.
- Instalar sobre una superficie plana (con una pendiente inferior a 2%) para reducir el riesgo de inestabilidad y lesiones.
- El producto debe ser instalado sobre una superficie adecuada, es decir, no se debe instalar sobre hormigón, losas, asfalto, pista o cualquier superficie dura/rota.
- El producto debe ser instalado en una zona segura y despejada, a 2 m de distancia de obstáculos o estructuras como vallas, garajes, casas, árboles/ramas suspendidas, tendederos o cables eléctricos, etc.
- Cualquier cambio en este juguete, p. cambiar o agregar un accesorio, debe hacerse de acuerdo con nuestras instrucciones. Si no lo hace, su garantía quedará anulada y sin efecto y puede hacer que su producto no sea seguro.
- Si es posible, oriente/posicione el producto de modo que los componentes de plástico (toboganes, columpios, etc.) tengan una exposición solar reducida

Velar por la seguridad de los niños que utilizan este producto es su responsabilidad, por lo que se aconseja que los niños estén vigilados en todo momento. No permita que los niños lleven ropa que pueda suponer un peligro, como ropa suelta (botones de trenca/flecos o el pelo suelto). También hay que tener cuidado de que el producto no se utilice de forma incorrecta, es decir, que se utilice de forma distinta a la prevista, y que no se permita a los niños subirse a zonas que no han sido diseñadas para ello.

INFORMACIÓN DE MADERA Y TRATAMIENTO

Todos los productos se fabrican utilizando madera de primera calidad. Los estrictos procesos de selección de madera garantizan que toda la madera se seleccione, corte y cepilla según las especificaciones correctas. Sin embargo, la madera es un material de producto natural y, por lo tanto, experimentará cambios tanto en apariencia como en composición durante su ciclo de vida. Esto significa que puede;

- formarse aberturas en la estructura de la madera siguiendo la veta, tales como grietas, fisuras, rendijas e incluso astillas. Estos espacios se forman por la diferencia de humedad que contienen las superficies internas y externas de la madera. Se trata de un proceso esperable en las estaciones secas y húmedas y no debe provocar ninguna inquietud puesto que no afectará la integridad estructural, la durabilidad o la garantía del producto.
- combarse o deformarse en general. Cualquier deformación o pandeo de la madera será ligero y no afectará la integridad estructural del equipo ni su disfrute.
- perder color a medida que la madera reacciona a la exposición a los rayos ultravioletas. La madera reaccionará con la luz del sol y perderá su color con el tiempo. Se recomienda tratar la madera anualmente con un producto específico.

La madera se suministra sin tratar, para que pueda decorarla y terminarla a su gusto y estilo. ¡Le recomendamos encarecidamente que trate su producto de madera tan pronto como lo construya! y continúe tratándolo regularmente para fortalecerlo frente a las diferentes condiciones climáticas. Si no se trata, su producto comenzará a deteriorarse más rápidamente.

Si construye y trata la madera durante las estaciones más húmedas, verifique el pronóstico del tiempo y construya durante un período de sequía. Asegúrese de que el producto esté seco antes de comenzar el tratamiento. Lo mismo aplica para el mantenimiento; para que se lleve a cabo en tiempo seco.

Una vez que haya aplicado su tratamiento de madera, debe asegurarse de que se mantenga adecuadamente. Siga las pautas de los fabricantes; la mayoría de los tratamientos deben volver a aplicarse cada tres a cinco años.

MANTENIMIENTO RUTINARIO

-Tal y como se ha indicado anteriormente, se aconseja realizar controles periódicos de mantenimiento del producto, al principio de la temporada y mensualmente a partir de entonces. Los elementos a revisar son: las piezas principales, las sujeciones, los tornillos y los tejidos. Si no se realizan las comprobaciones periódicas, pueden, anclas causar lesiones.

-Comprobar regularmente el apriete de la fijación y volver a apretar si es necesario, mantener las juntas lubricadas y sustituir las cubiertas de fijación/borde que falten

-Cualquier accesorio, como los columpios y las cuerdas, debe ser revisado regularmente para localizar evidencias de degradación o deterioro. Sustituya cualquier pieza que muestre signos de ello.

-Durante largos periodos de inactividad, se recomienda desmontar el producto y almacenarlo en un lugar seco y fresco, como en garajes o cobertizos. Esto prolongará la vida del producto en condiciones climáticas adversas, esto no incluye la madera.

-Recuerde guardar este manual en un lugar seguro para poderlo consultar y utilizar en el futuro.

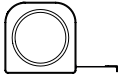

ALL MEASUREMENTS ARE IN MILLIMETRES
(mm) UNLESS STATED OTHERWISE

PRE-DRILL

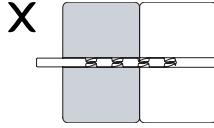
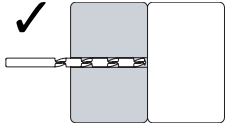

FIX WITH SCREW

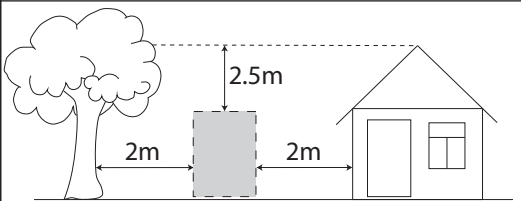
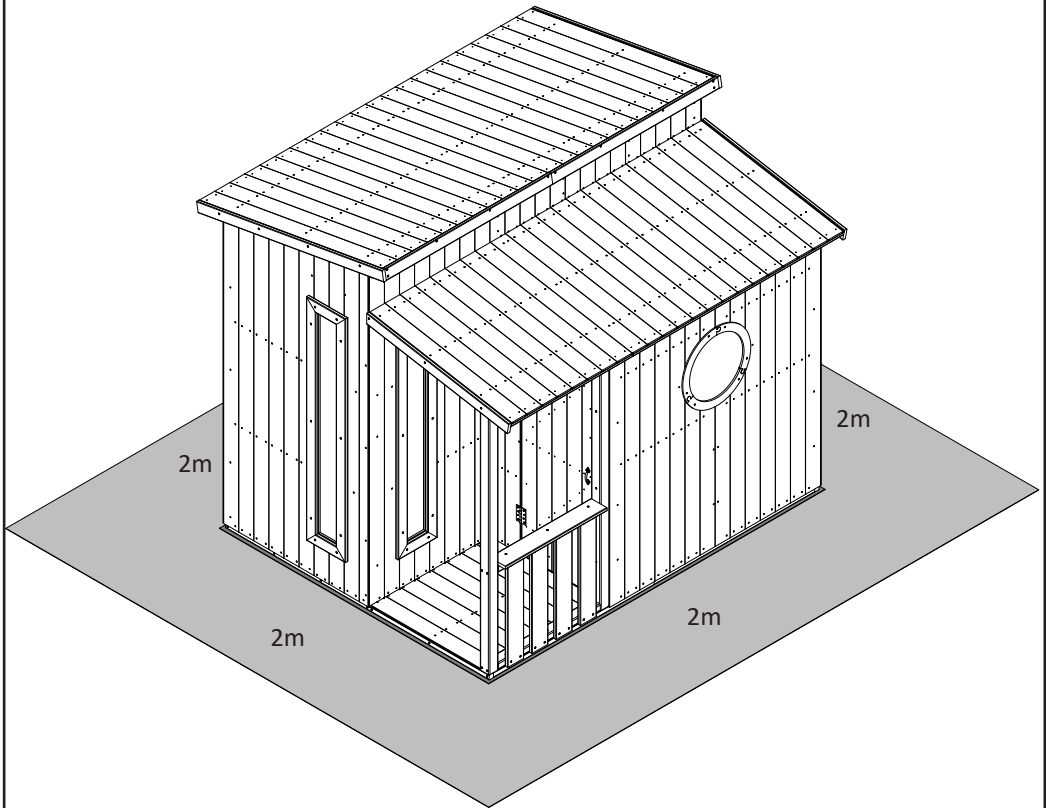
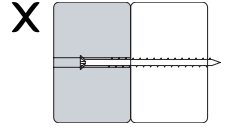
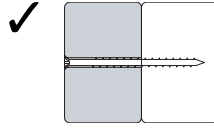

The safe play area refers to the zone extending 2m around the product on all sides and 2.5m above the product.

You will need/supplied...

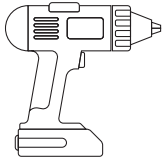

Powered Drill



3mm Drill Bit

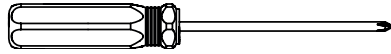

Screwdriver

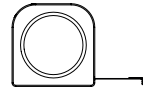
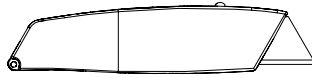
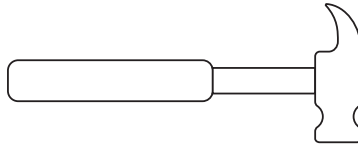
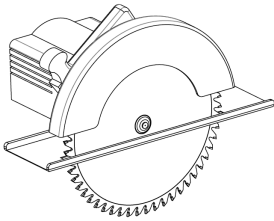
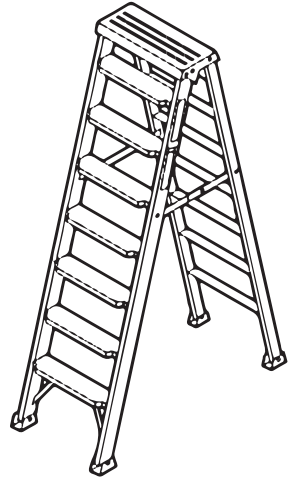

Tape Measure

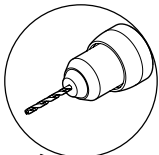

PRE-DRILL

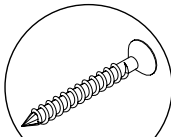

FIX WITH SCREW

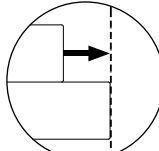

ALIGN

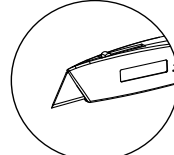

TRIM

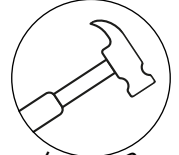

HAMMER



2x

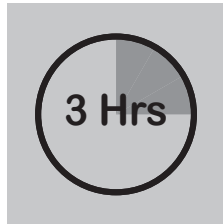

3 Hrs

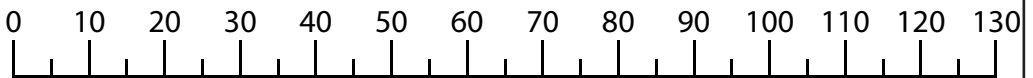

mm

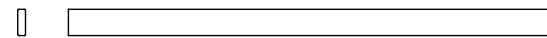

W1 WD01-1237 (69x20) x 1237mm x 8

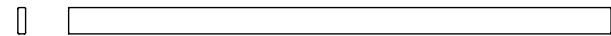

W2 WD01-1400 (69x20) x 1400mm x 2



W3 WD02-0670 (120x20) x 670mm x 4



W4 WD02-0755 (120x20) x 755mm x 1

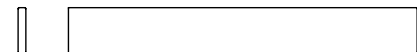

W5 WD02-0900 (120x20) x 900mm x 5

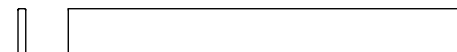

W6 WD02-1006 (120x20) x 1006mm x 19



W7 WD02-1030 (120x20) x 1030mm x 1

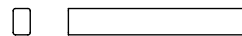

W8 WD03-0450 (69x44) x 450mm x 3



W9 WD03-0756 (69x44) x 756mm x 2

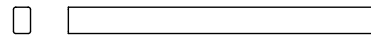

W10 WD03-0786 (69x44) x 786mm x 1

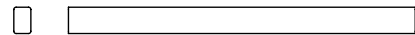

W11 WD03-0895 (69x44) x 895mm x 1

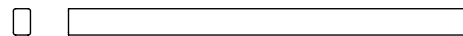

W12 WD03-1020 (69x44) x 1020mm x 1

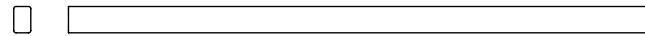

W13 WD03-1492 (69x44) x 1492mm x 1

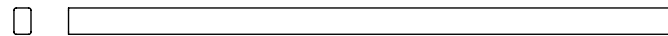

W14 WD03-1556 () x 1556mm x 1

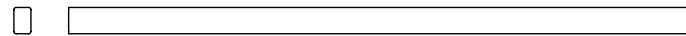

W15 WD03-1600 (69x44) x 1600mm x 1

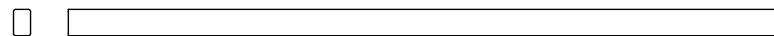

W16 WD03-1834 (69x44) x 1834mm x 1

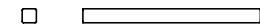

W17 WD09-0400 (32x32) x 400mm x 7

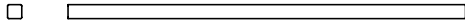

W18 WD09-0896 (32x32) x 896mm x 1

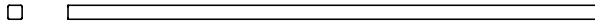

W19 WD09-1194 (32x32) x 1194mm x 14

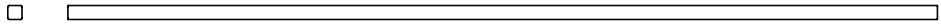

W20 WD09-1960 (32x32) x 1960mm x 2

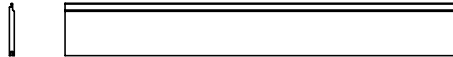

W21 WD10-0878 (120x11) x 878mm x 8

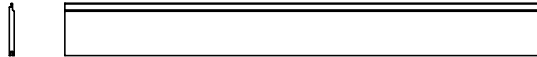

W22 WD10-1070 (120x11) x 1070mm x 8

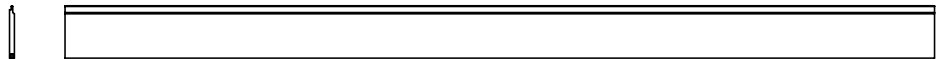

W23 WD10-1960 (120x11) x 1960mm x 14

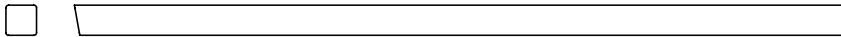

W24 WD1886 (69x69) x 1738mm x 2



W25 WD1887 (69x20) x 1072mm x 2



W26 WD1889 (69x20) x 1568mm x 8

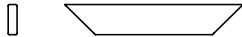

W27 WD1890 (69x20) x 402mm x 4

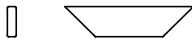

W28 WD1910 (69x20) x 290mm x 4

W29 PH079 817 x 2010 x 43

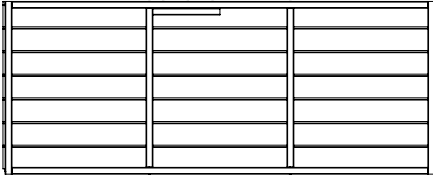

W30 PH080 904 x 2010 x 43

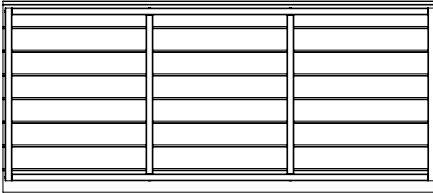

W31 PH081 817 x 2010 x 43

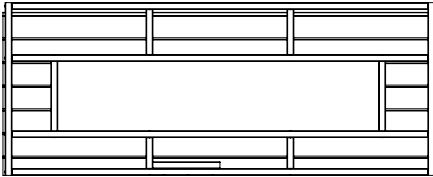

W32 PH082 1081 x 2200 x 43

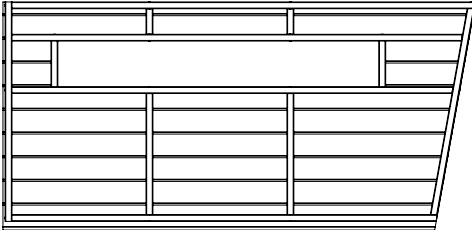

W33 PH083 1081 x 2200 x 43

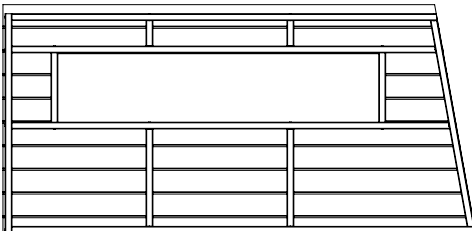

W34 PH084 890 x 1894 x 43

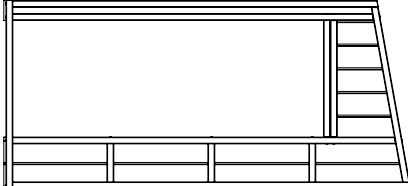

W35 PH085 890 x 1894 x 43

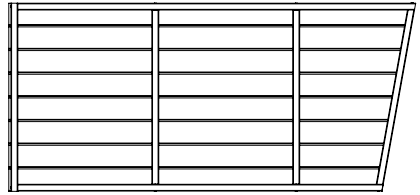

W36 PH086 939 x 2200 x 43

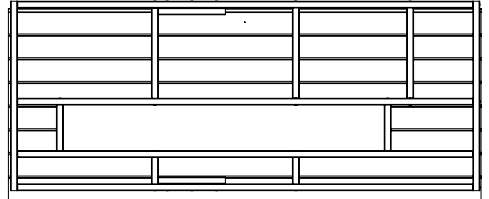

W37 PH087 1576 x 310 x 43



W38 PH088 789 x 1739 x 43

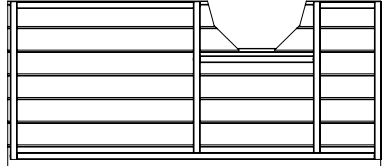

W39 PH089 792 x 1739 x 43

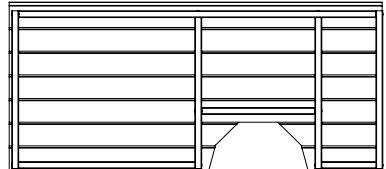

W40 PH090-A 1380 x 792 x 43

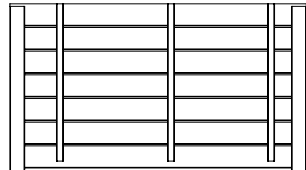

W41 PH090-B 1380 x 936 x 43

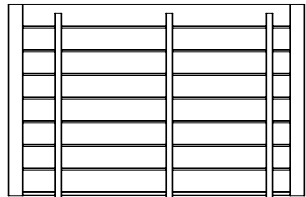

W42 PH090-C 1380 x 792 x 43

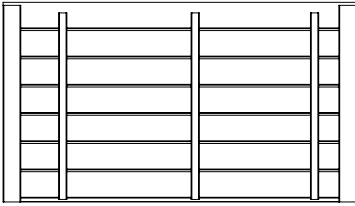

W47 PH093 1500 x 544 x 32

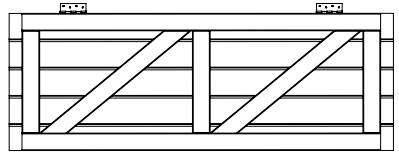

W43 PH091-A 1070 x 1576 x 43

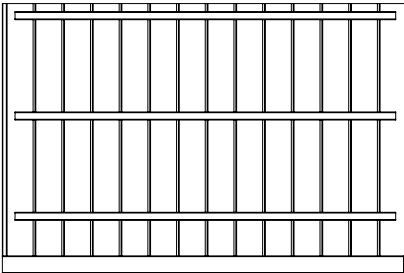

W48 PH096 500 x 500 x 25

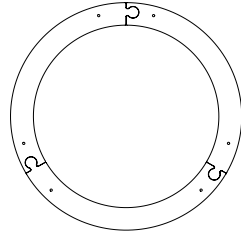

W44 PH091-B 1070 x 905 x 43

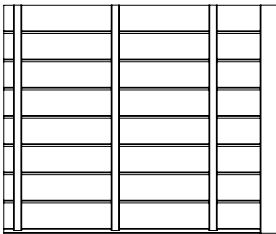

W45 PH094 1494 x 328 x 32

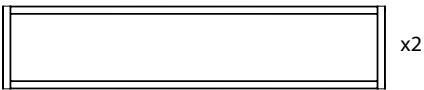

x2

W46 PH095 1494 x 216 x 32

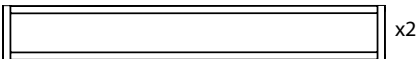

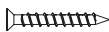

x2

 5 x 35mm x 80

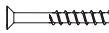
 5 x 55mm x 340

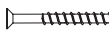
 5 x 80mm x 85

 5 x 100mm x 12

 2 x 40mm x 310

 3.6 x 16mm x 10

FOUNDATION PLAN

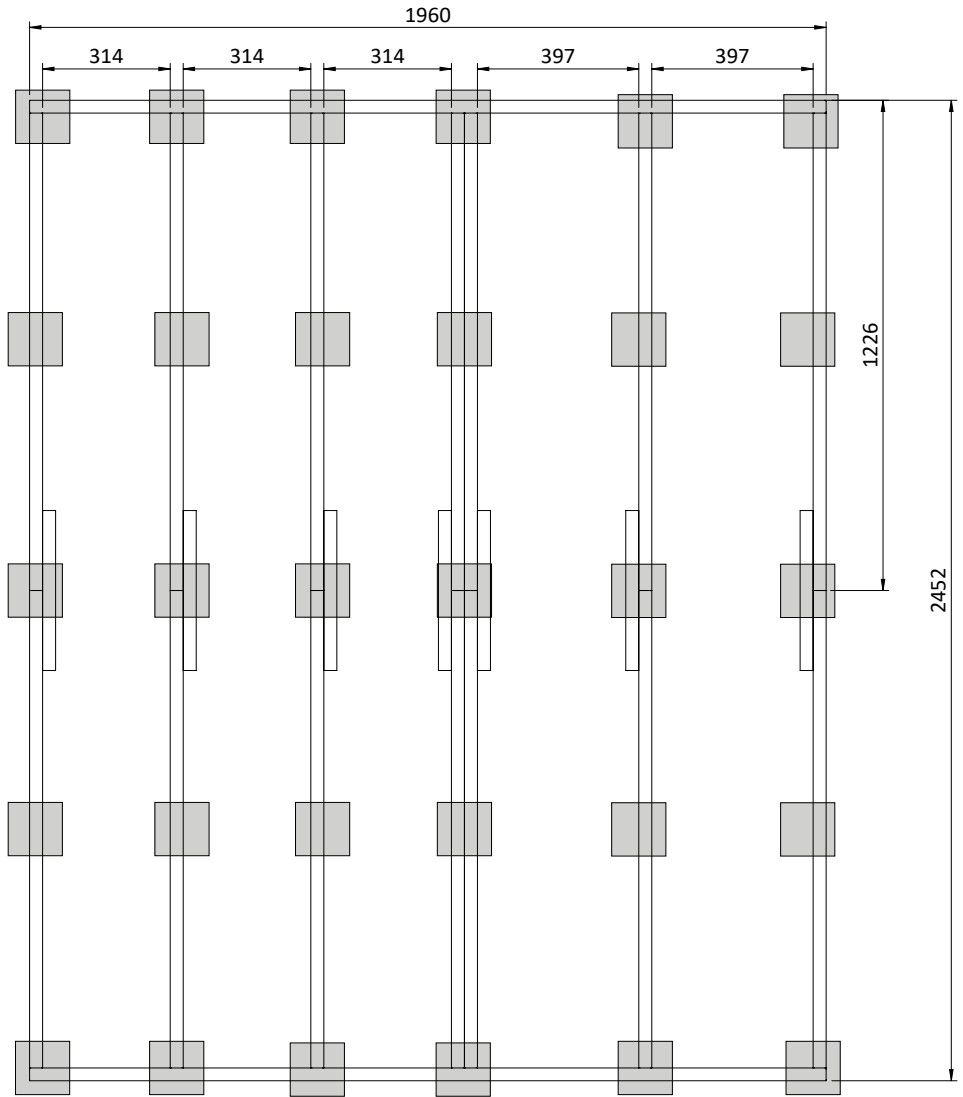

1

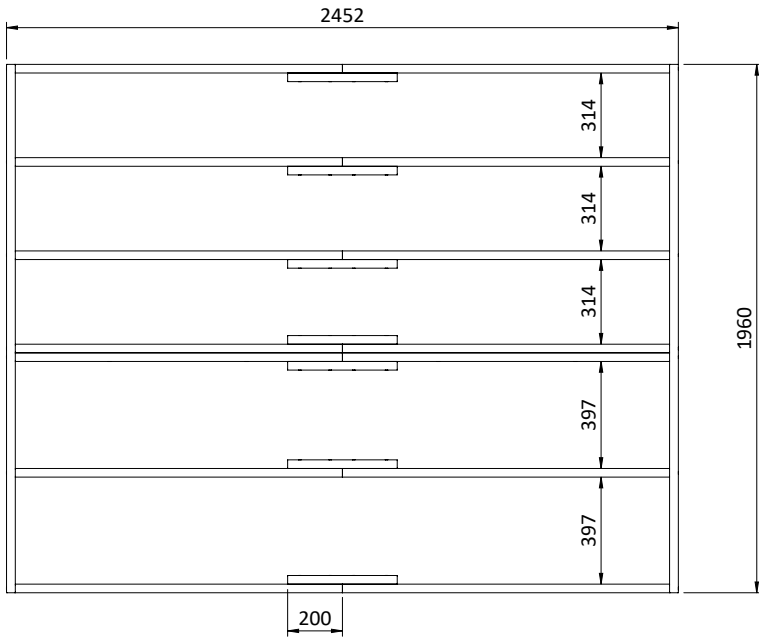

W17

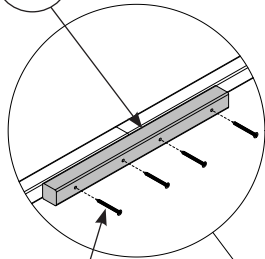

55mm

W19

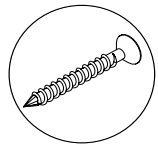
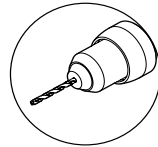
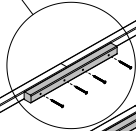

W20

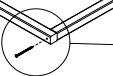

80mm

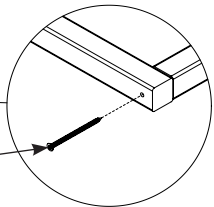

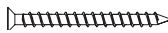
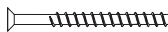
-  5 x 55mm x 32
-  5 x 80mm x 14

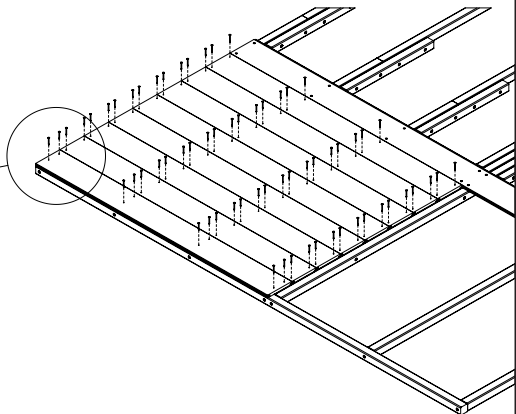
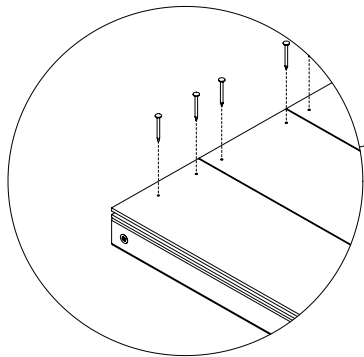
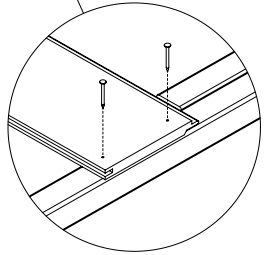
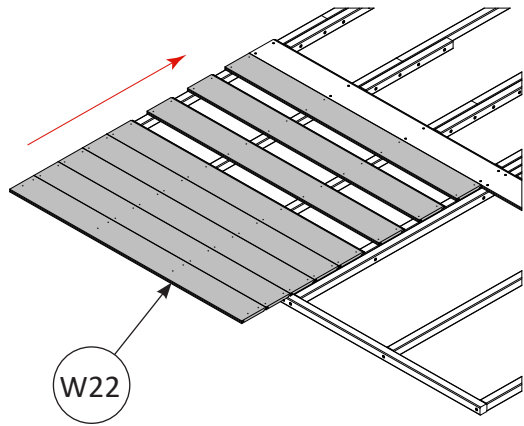
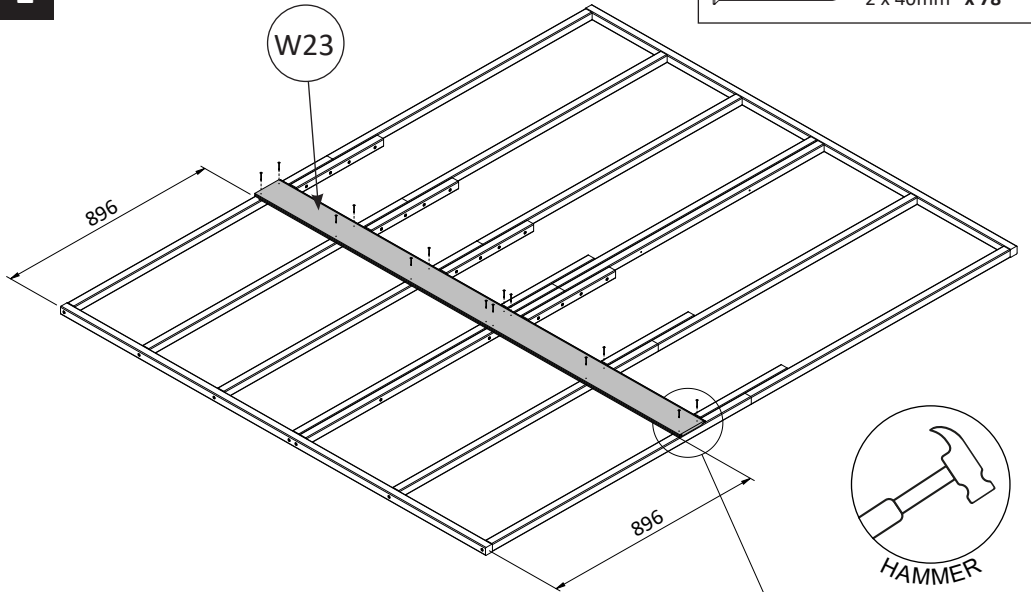
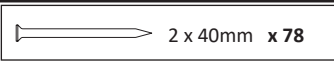

3

2 x 40mm x 182

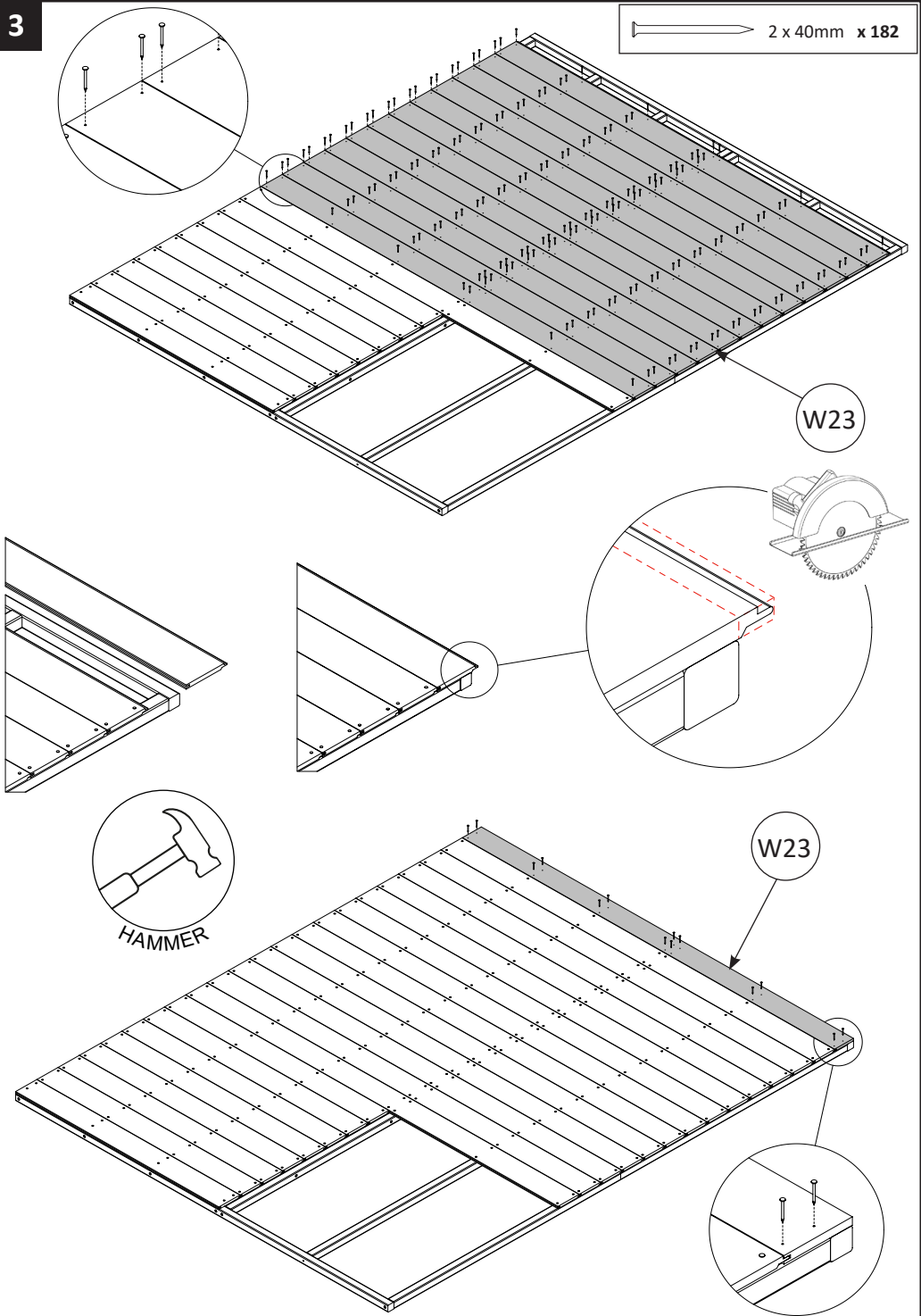

4

5 x 55mm x 12

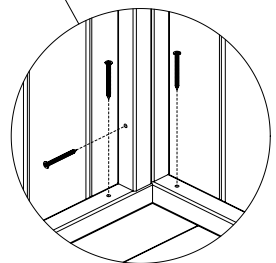
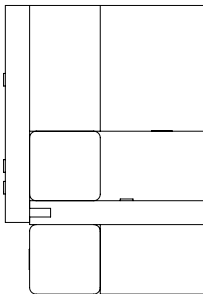
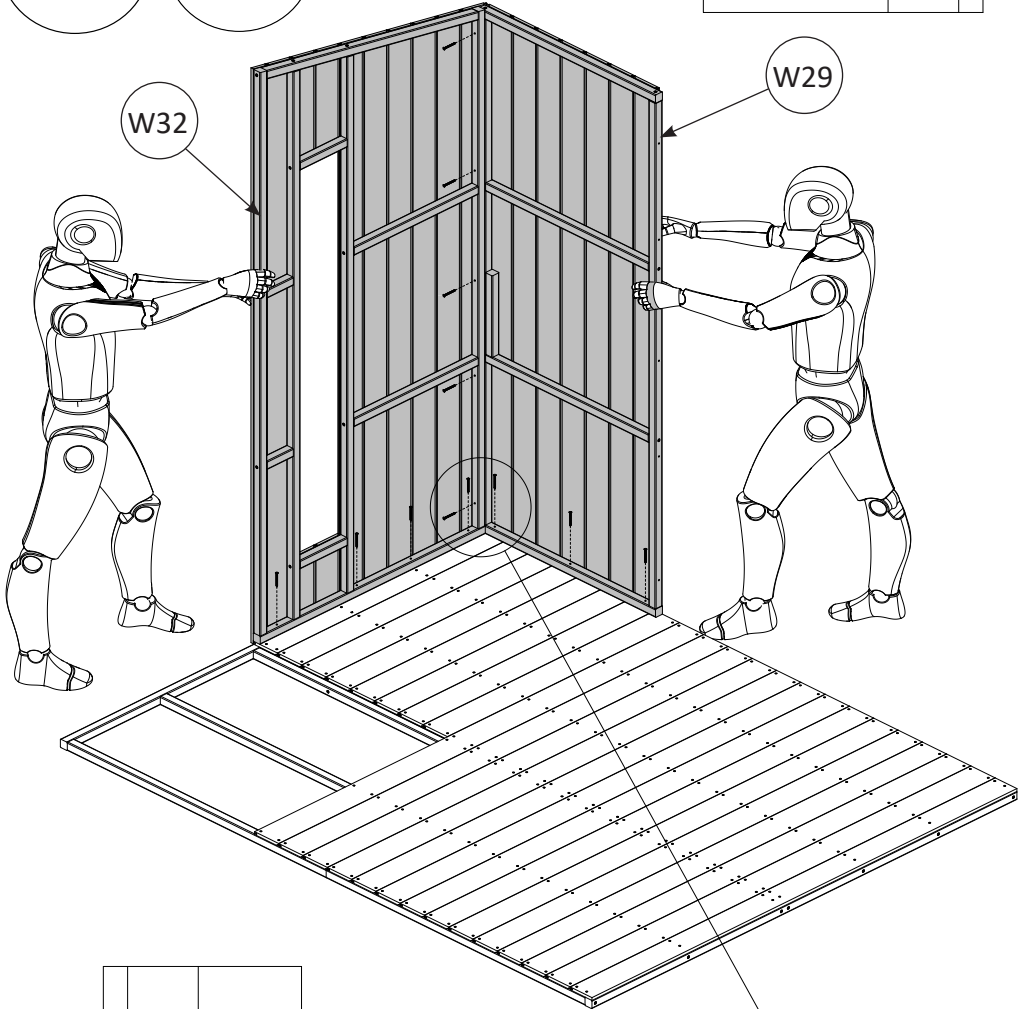
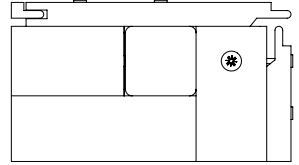
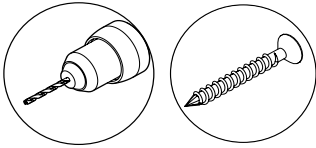

5

 5 x 55mm x 8

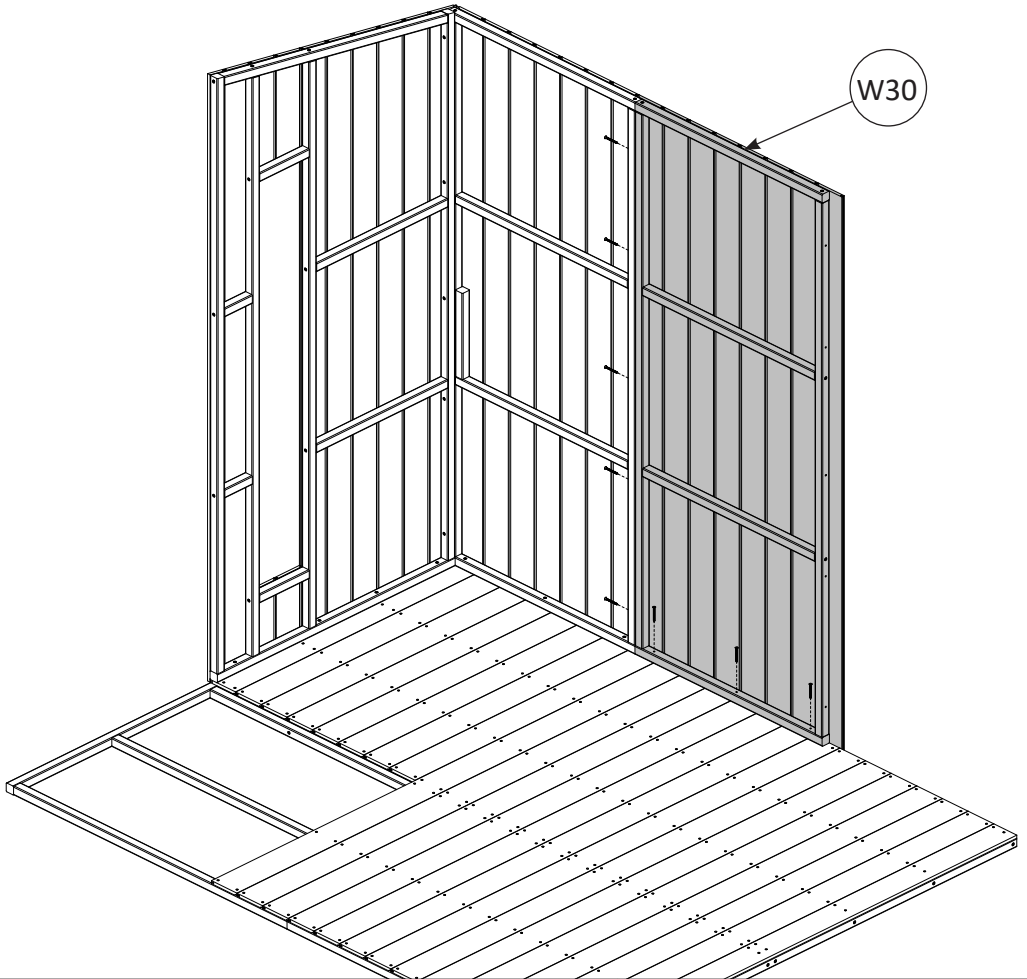
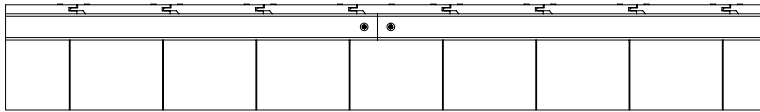
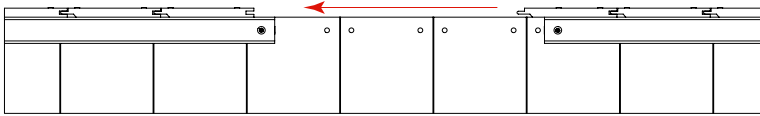
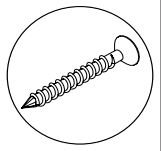
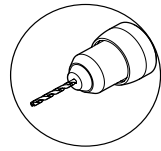

6

 5 x 55mm x 8

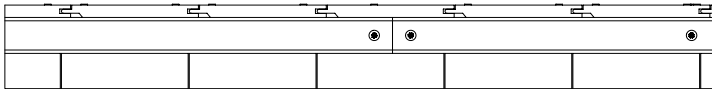
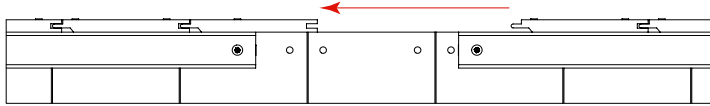
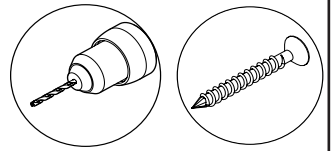

W31

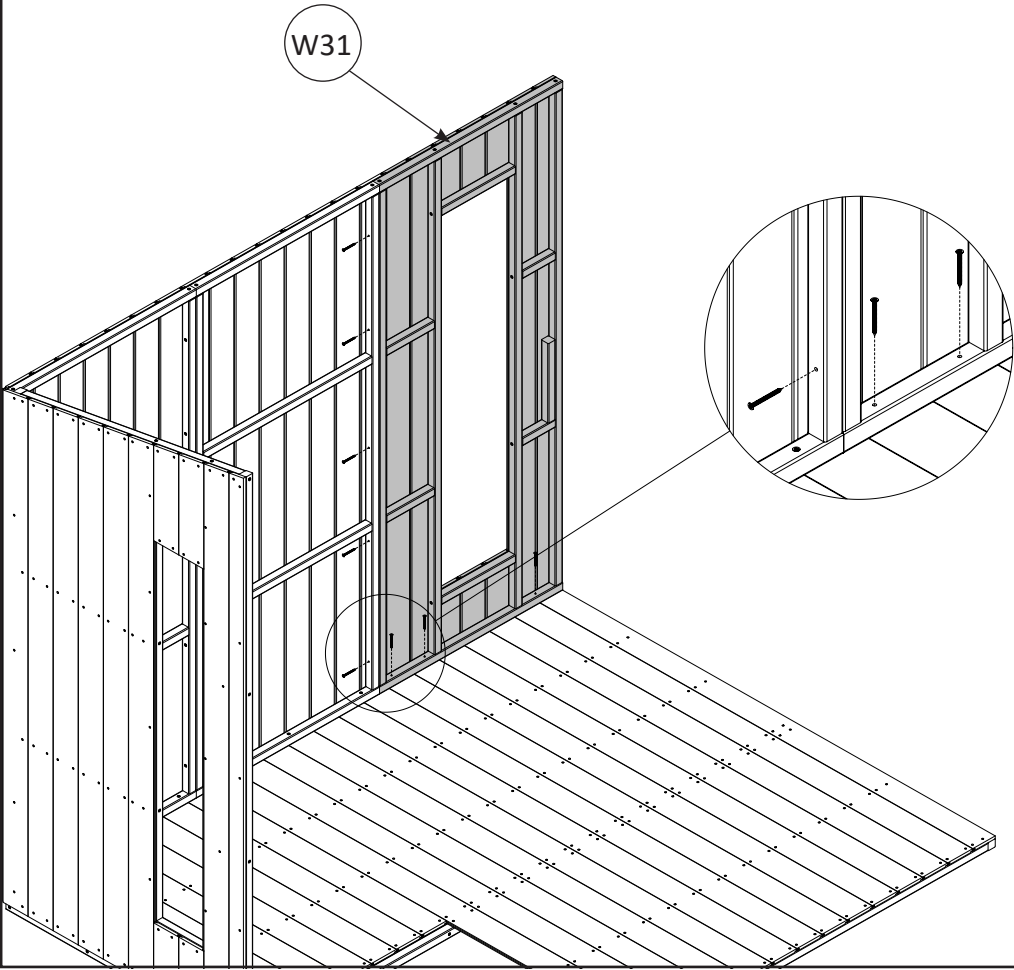

7

5 x 55mm x 8

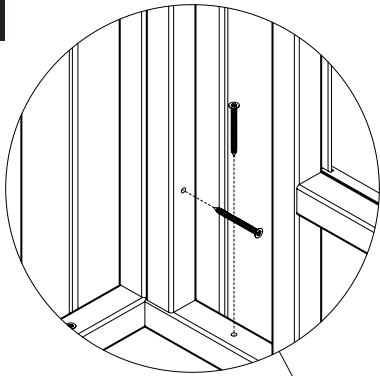
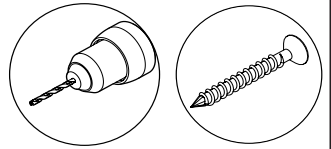

W33

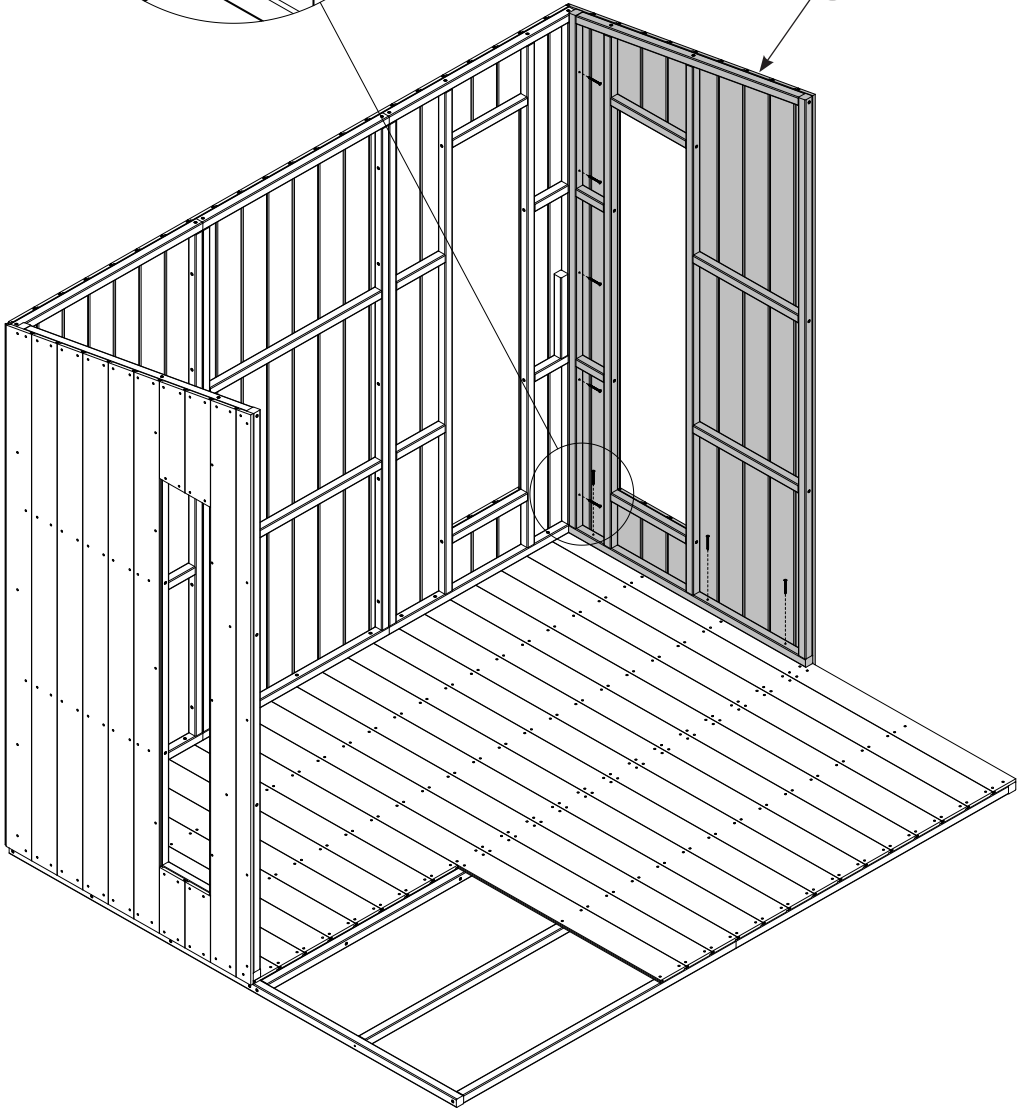

8

5 x 55mm x 8

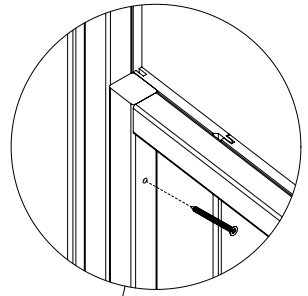
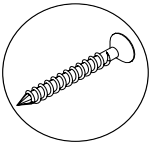
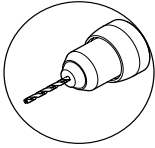

W35

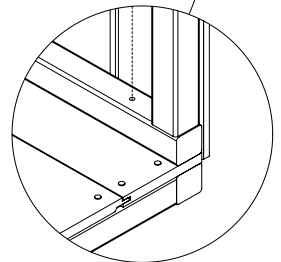
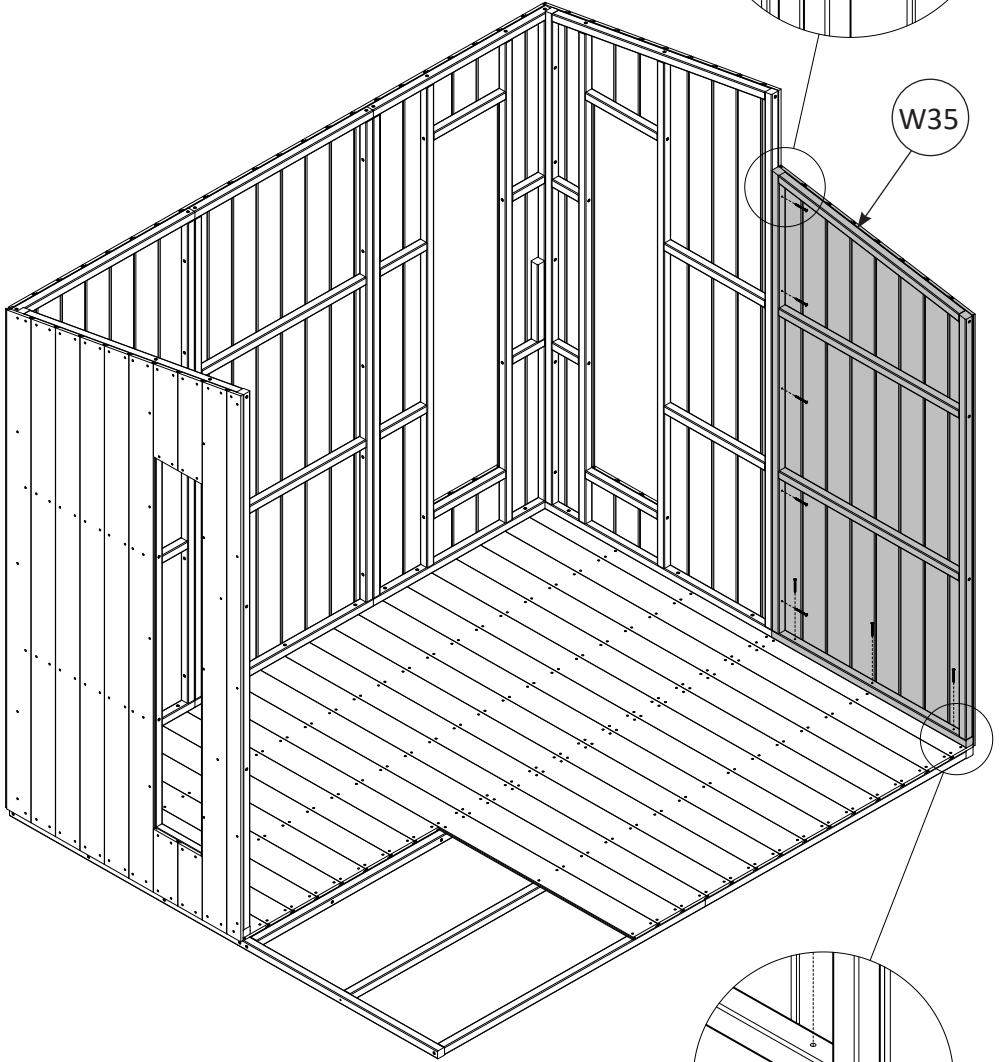

9

5 x 55mm x 10

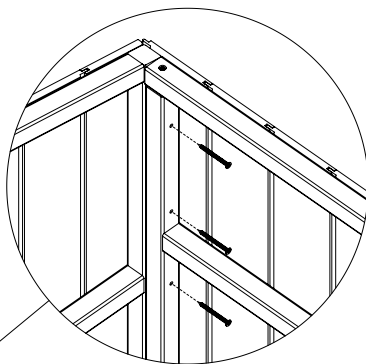
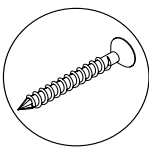
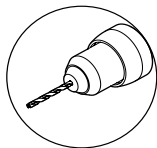

W39

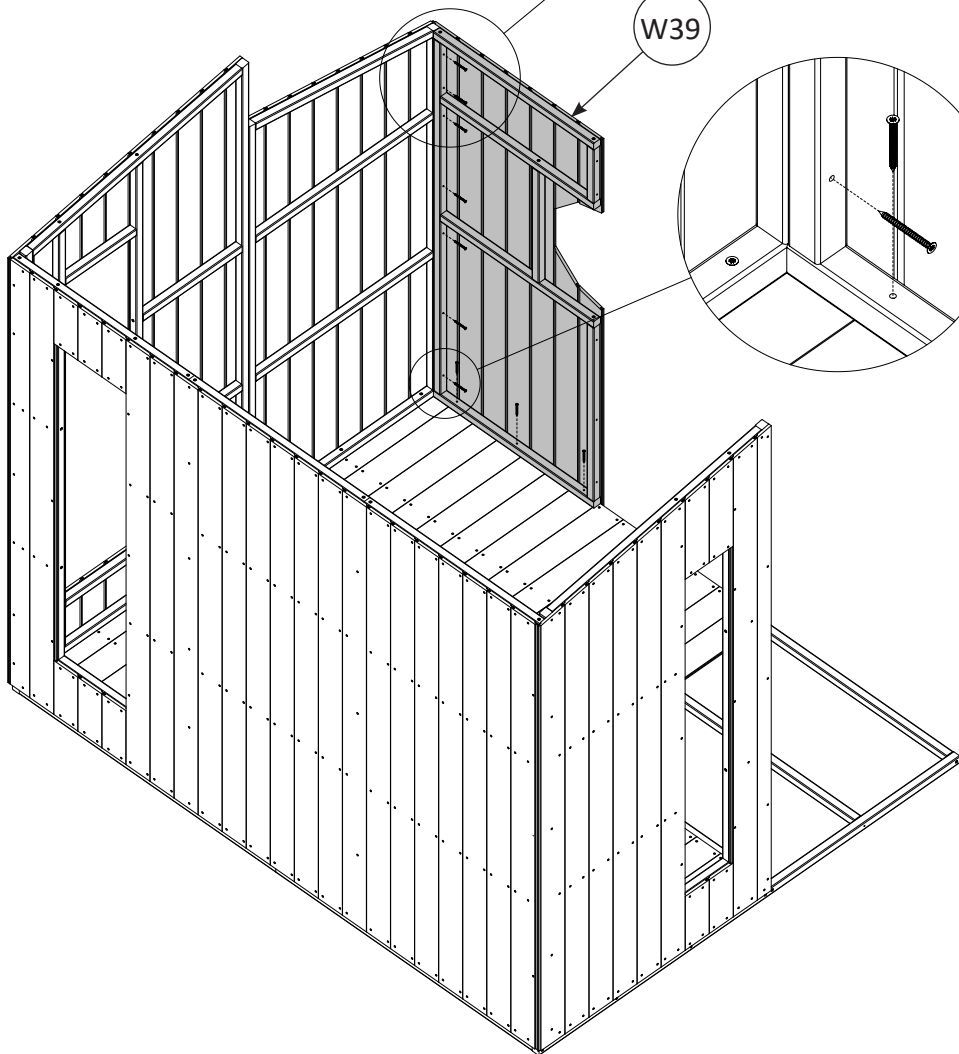
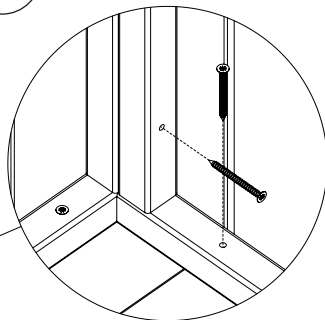

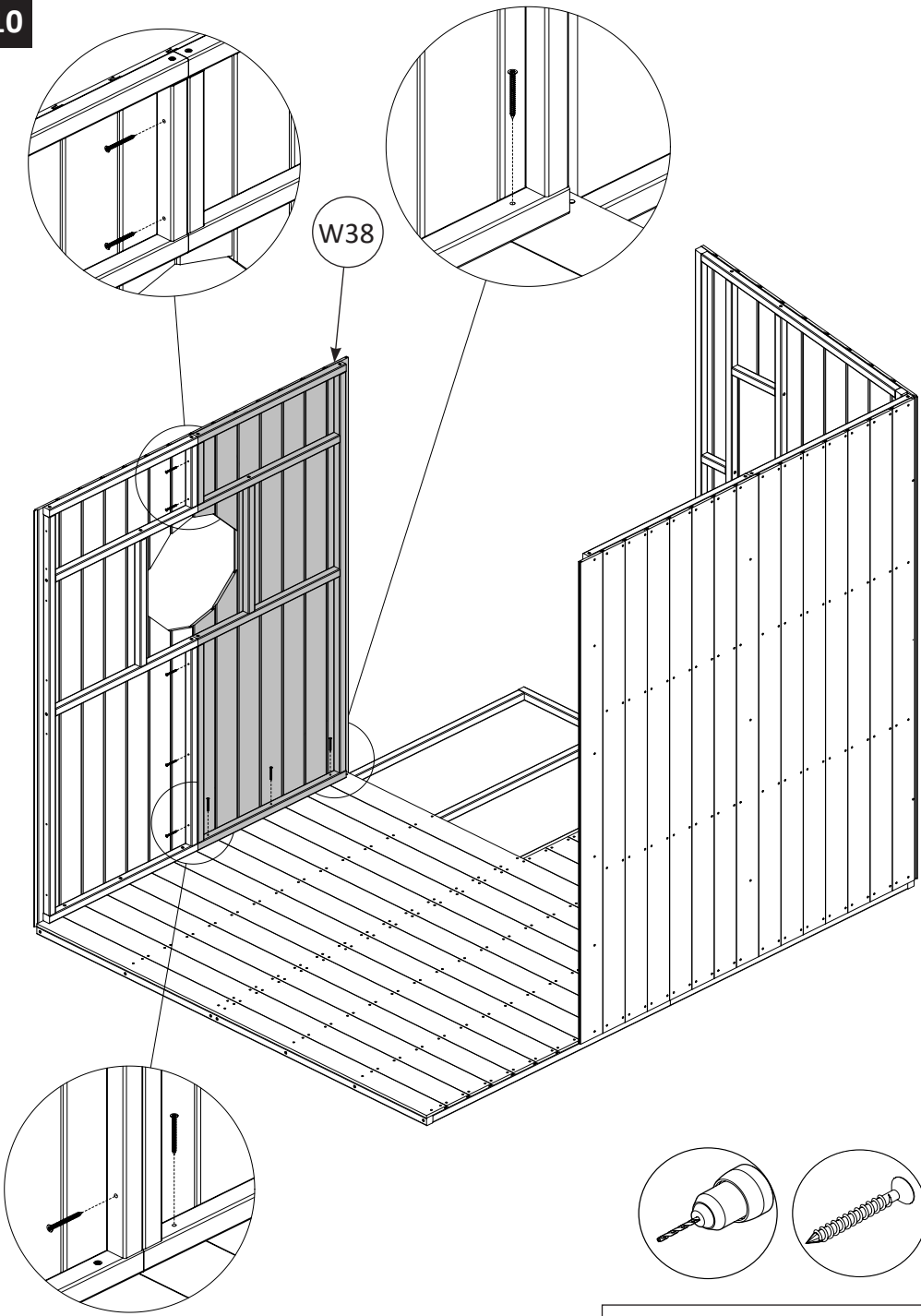

W38

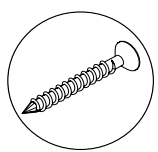

 5 x 55mm x 8

5 x 55mm x 11

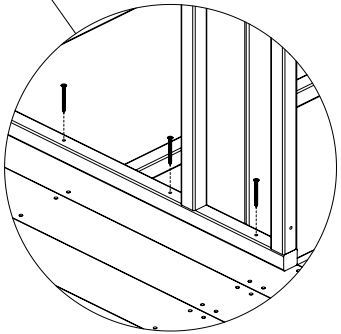
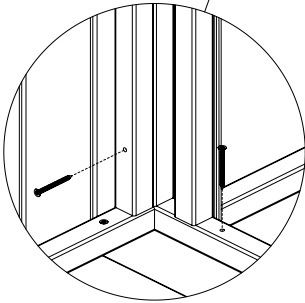
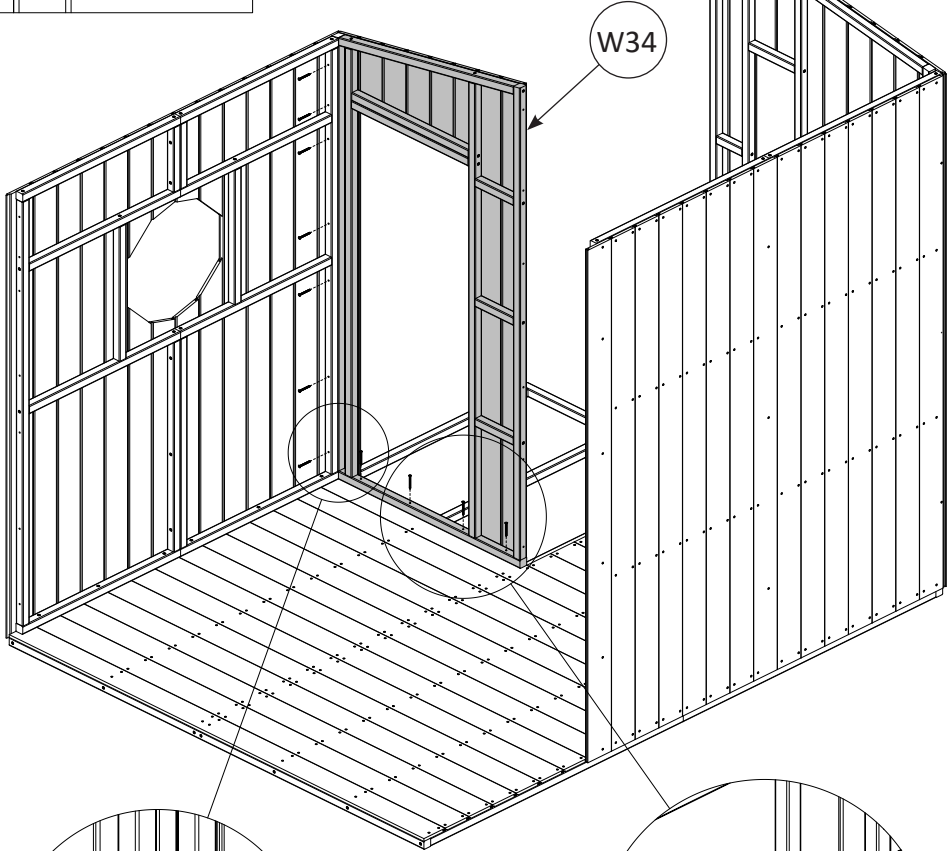
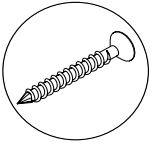
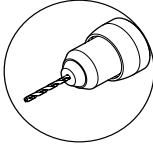
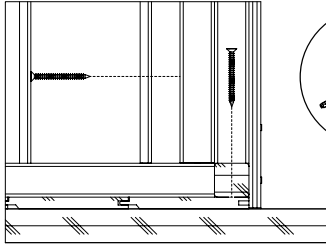
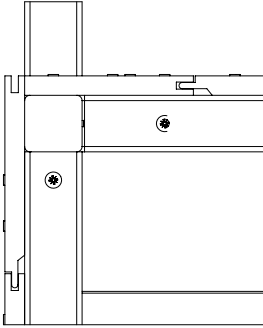

5 x 55mm x 14

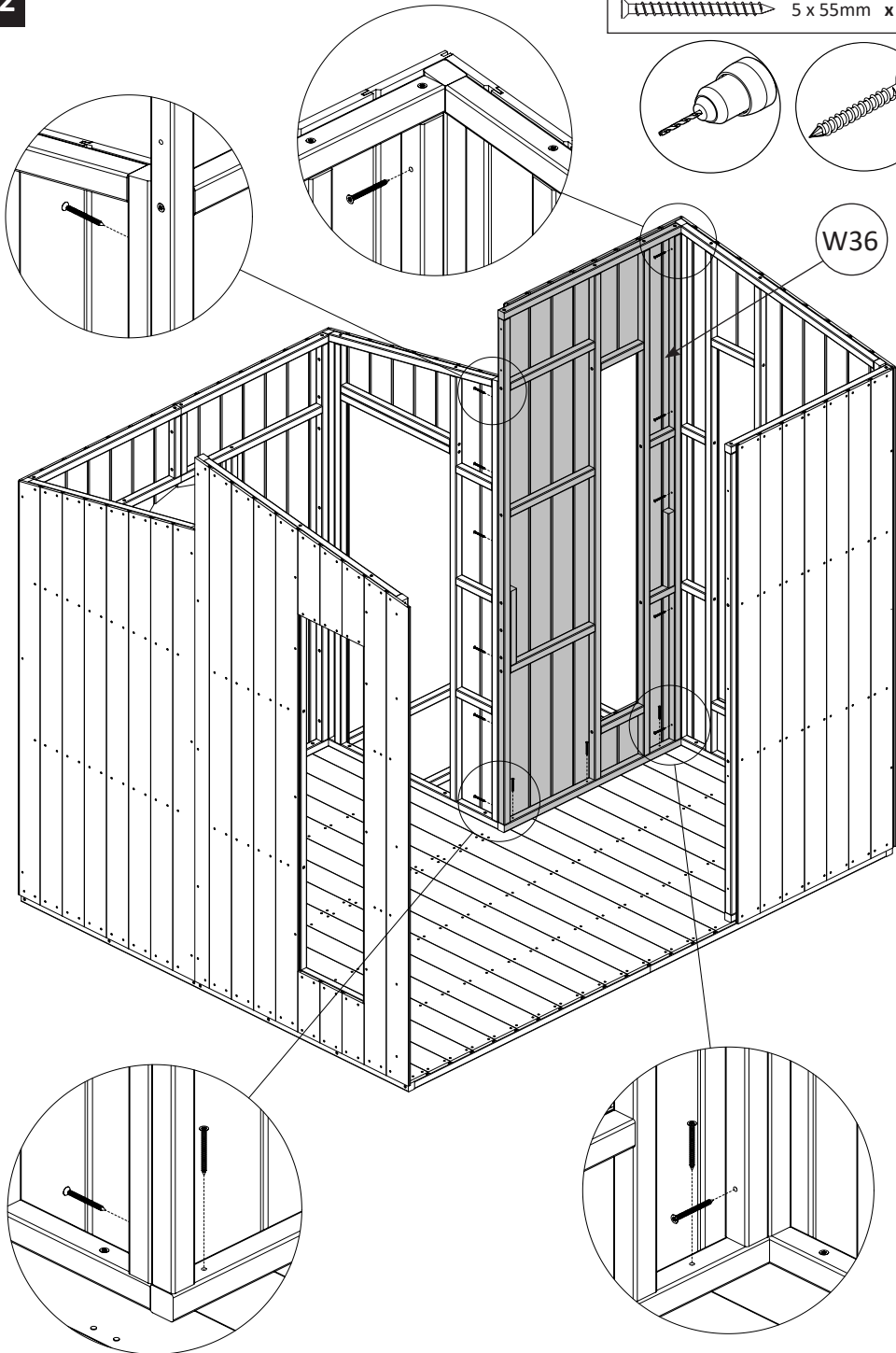
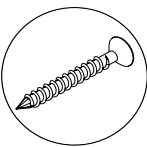

5 x 55mm x 4

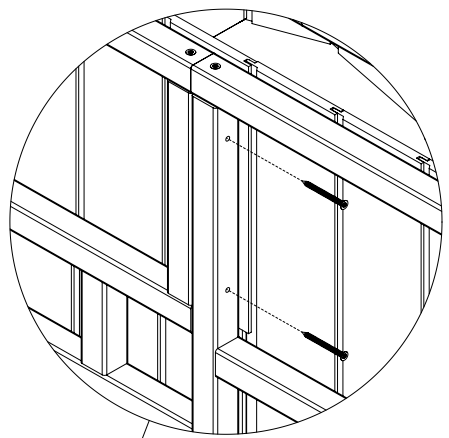
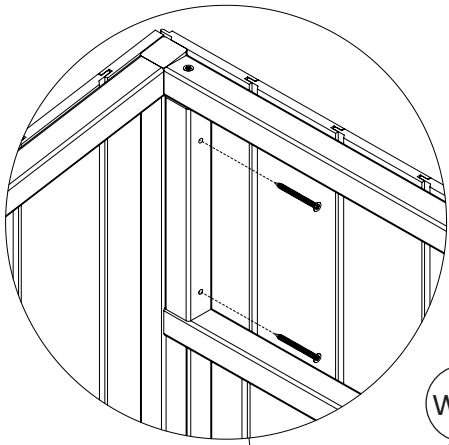
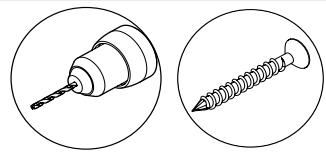

W37

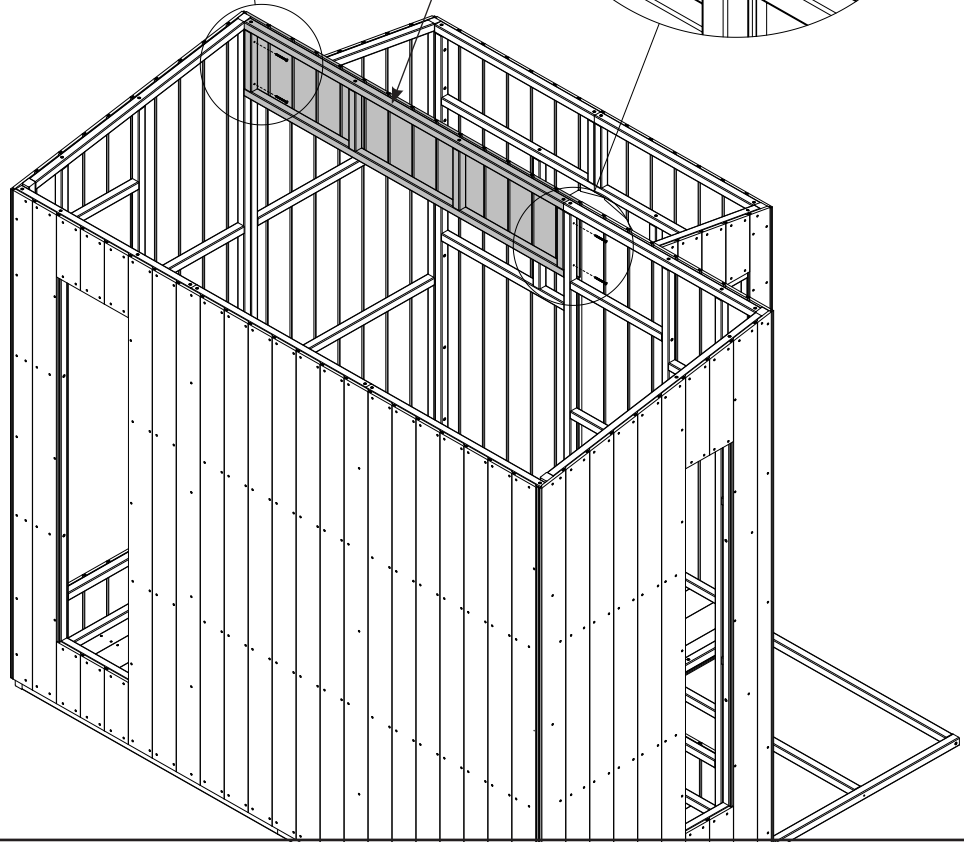

14

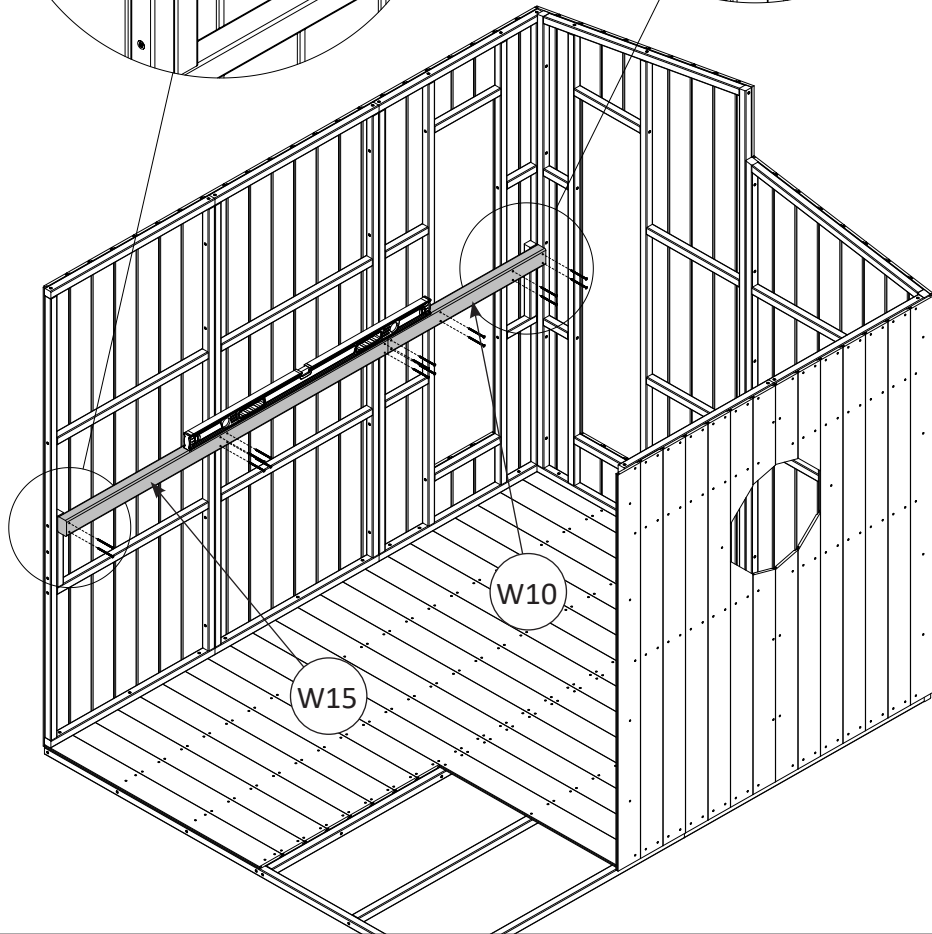
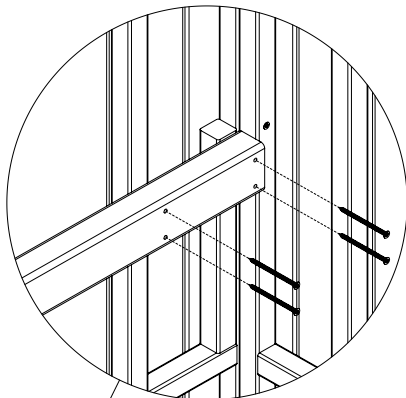
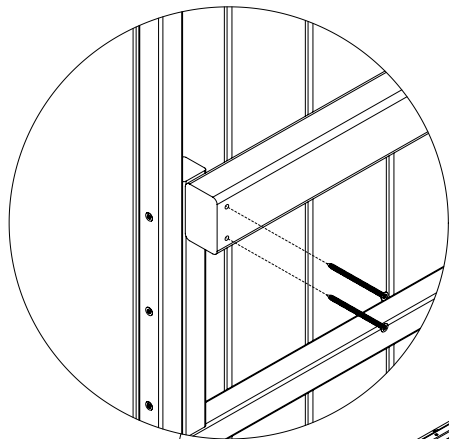
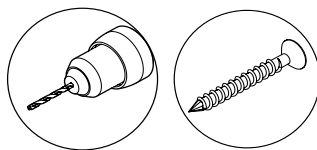
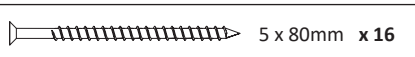

15-A

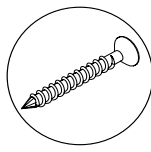
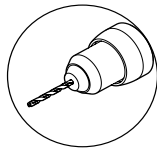

5 x 80mm x 12

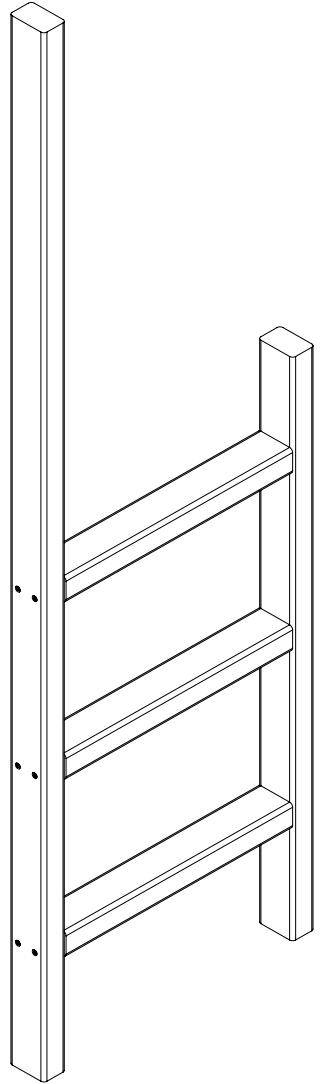
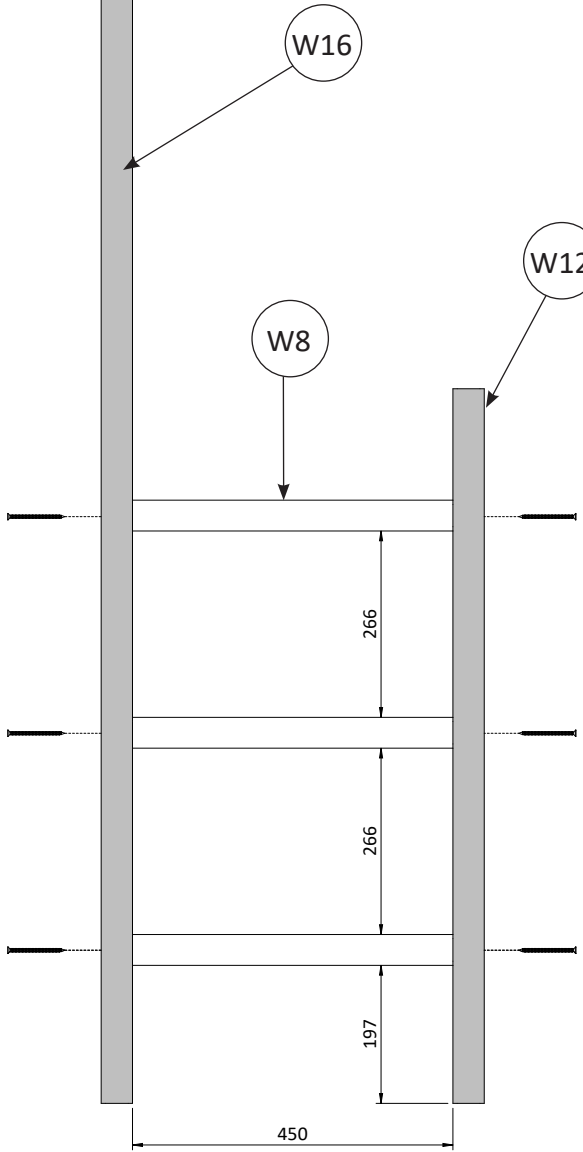

15-B

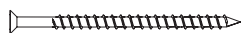
 5 x 80mm x 19

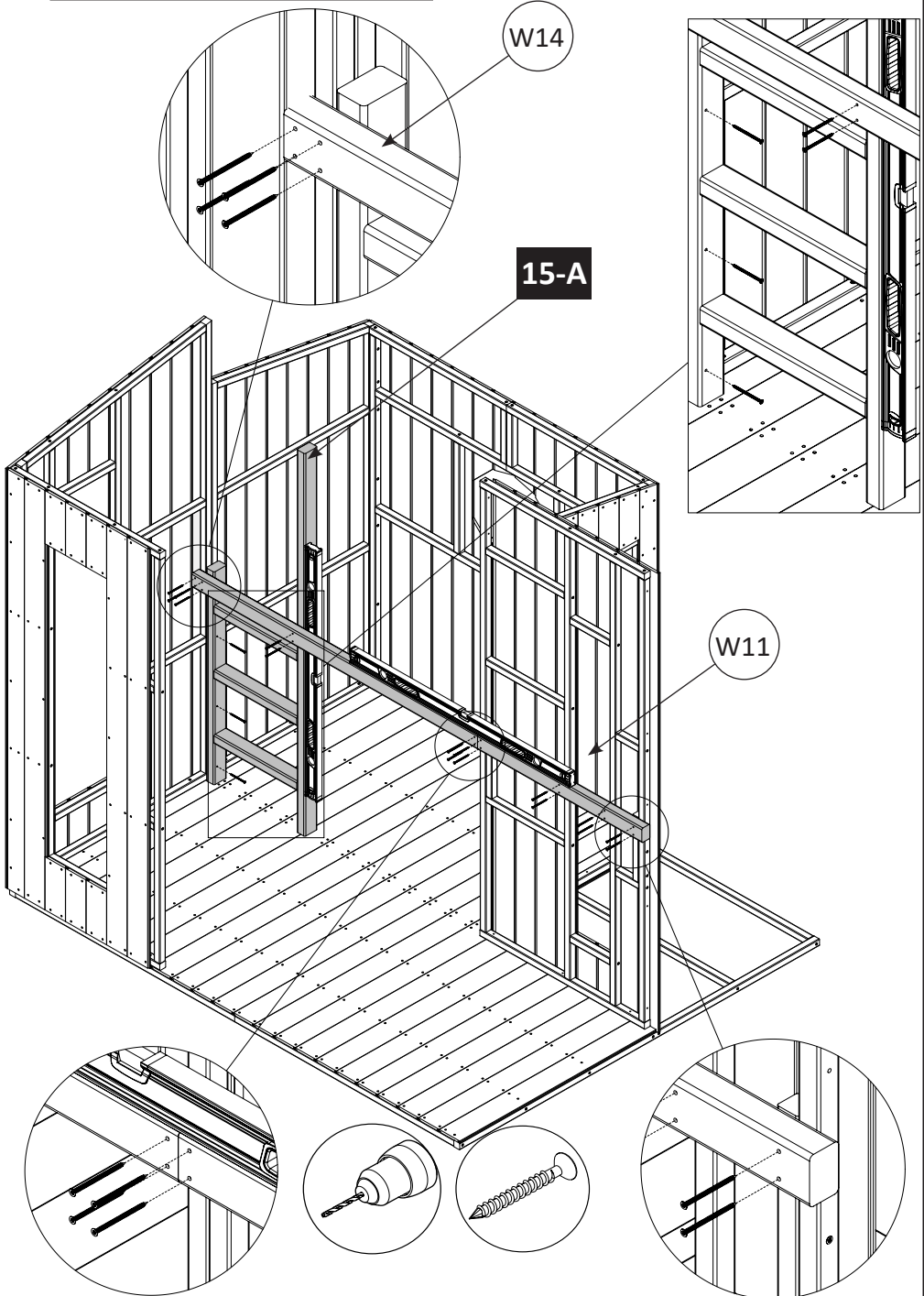

16

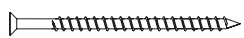

5 x 80mm x 19

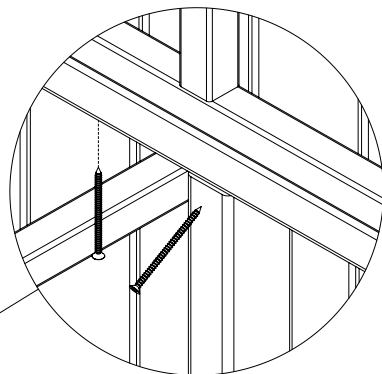
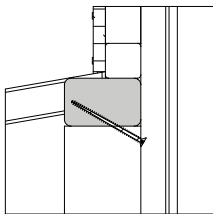
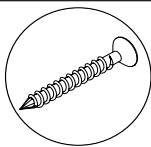

W13

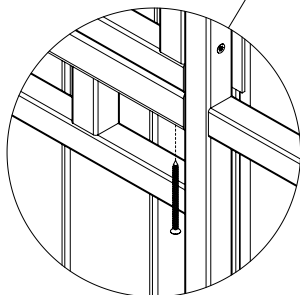
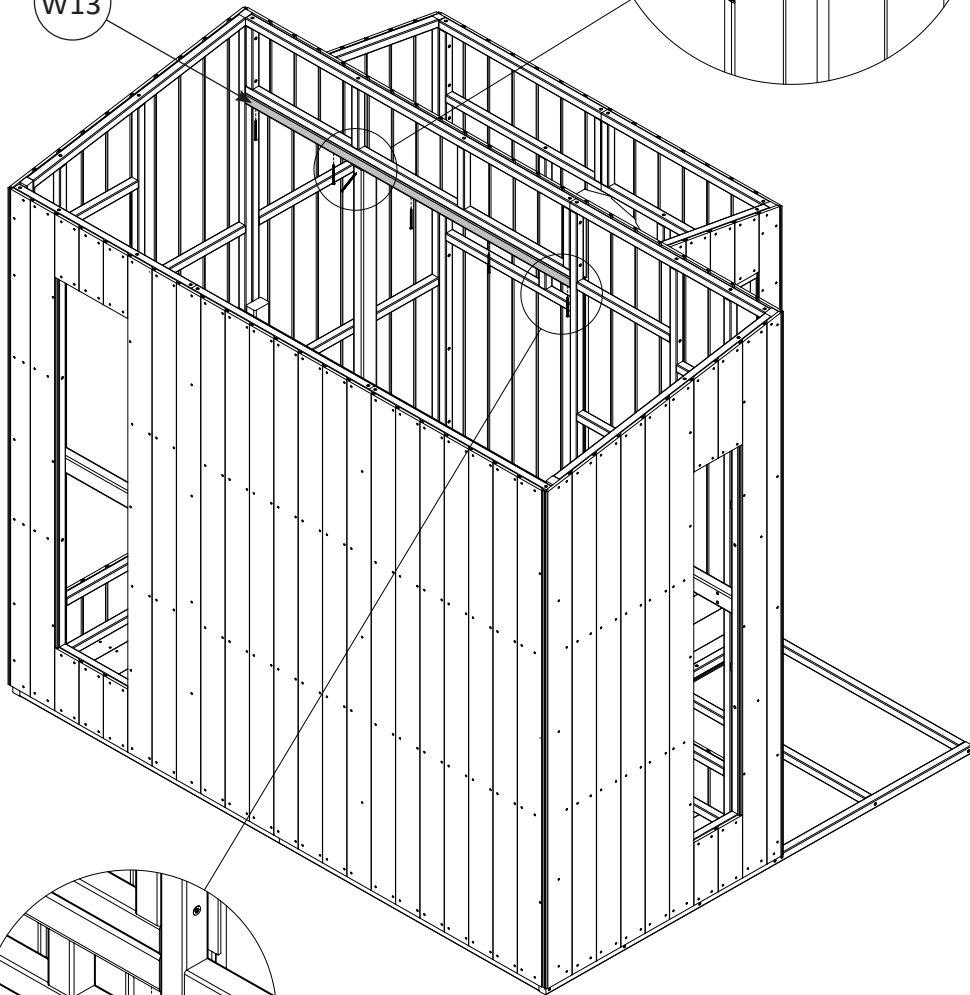

5 x 55mm x 76

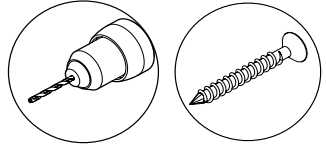

W6

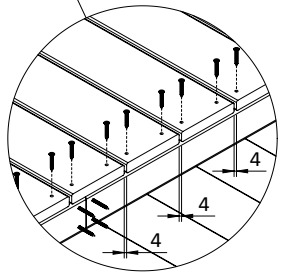
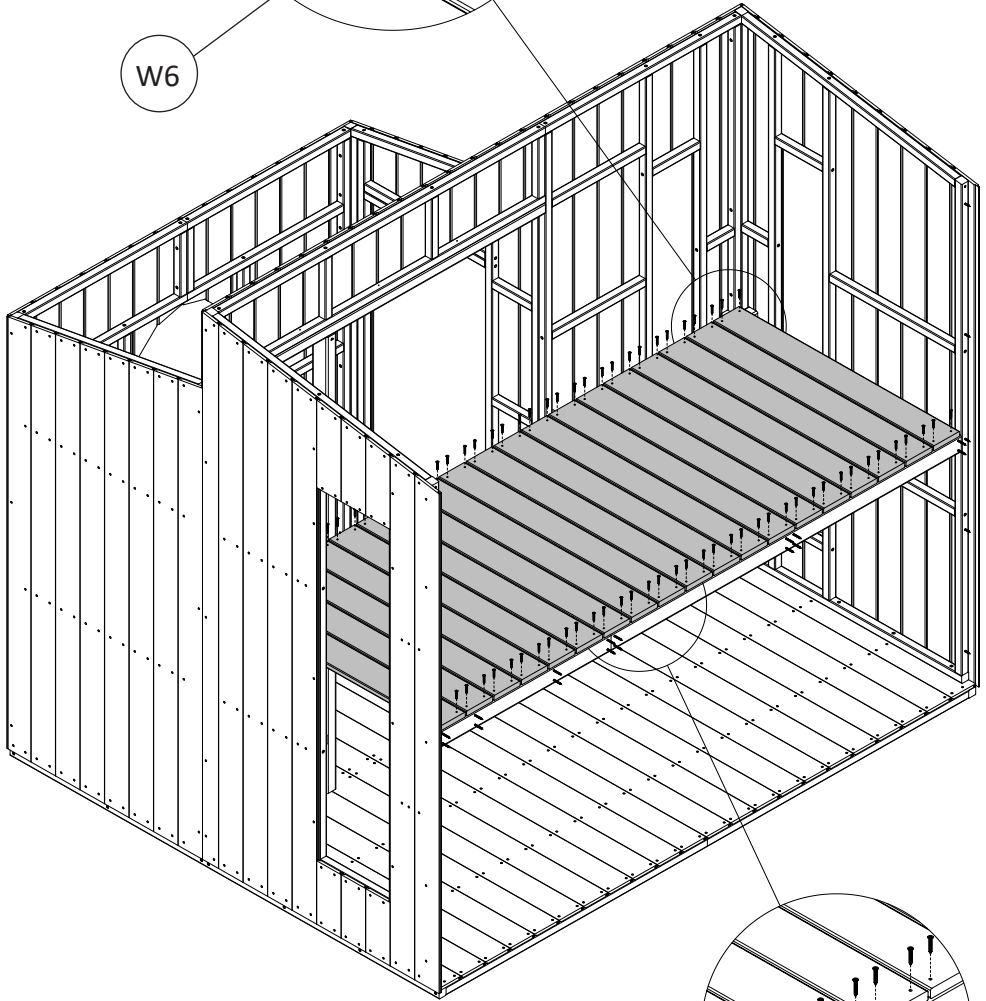
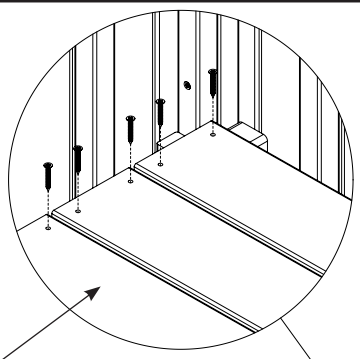

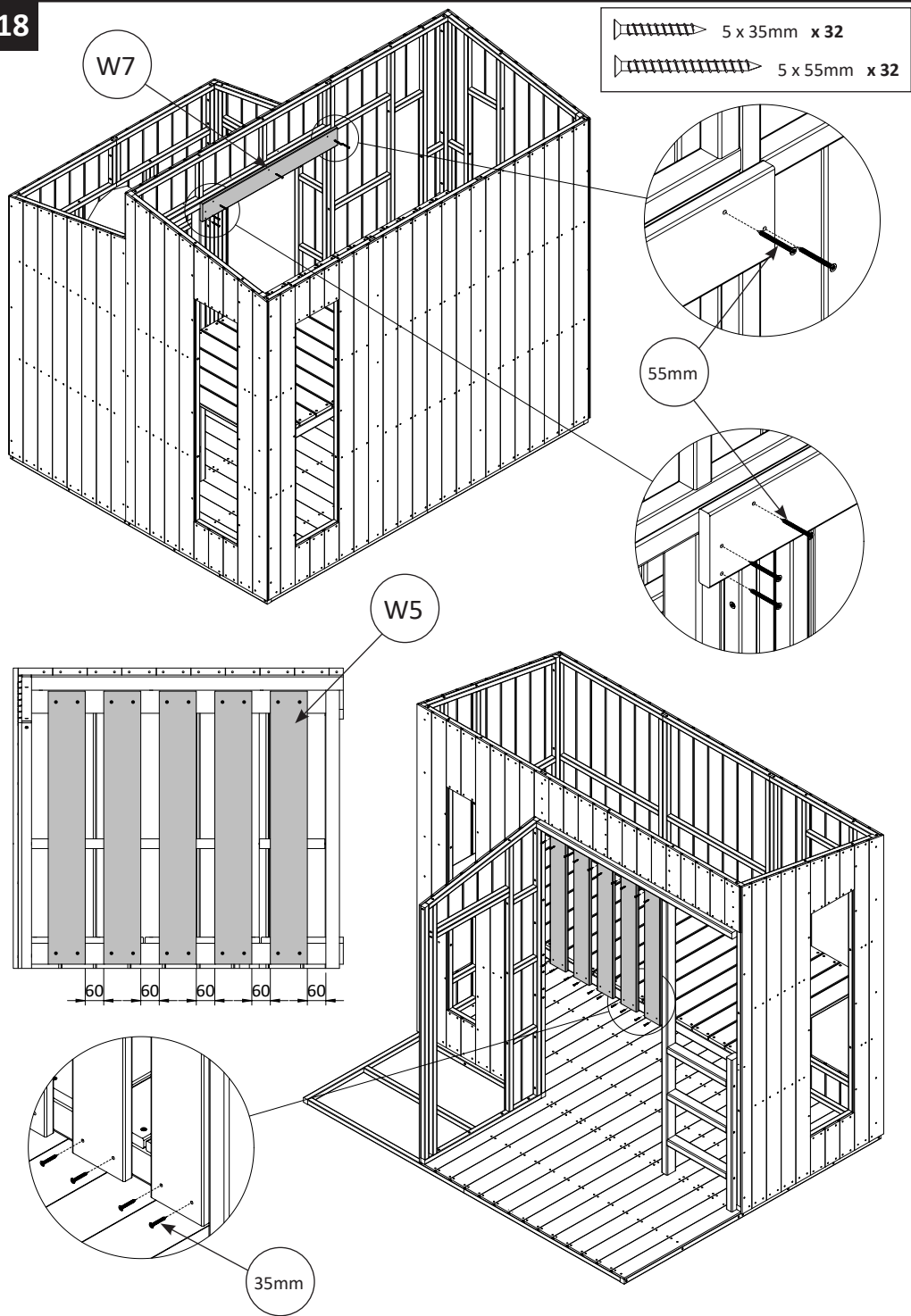

2 x 40mm x 48

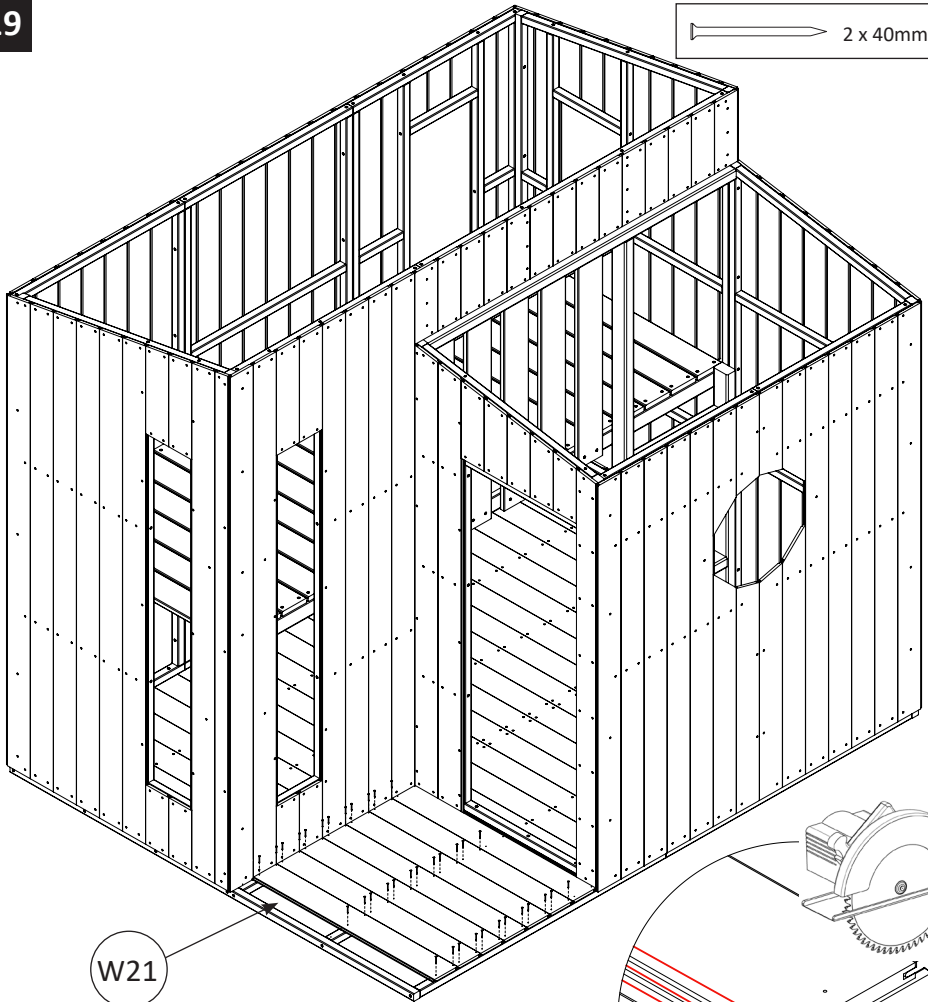

W21

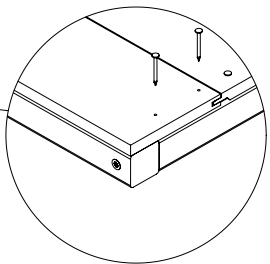
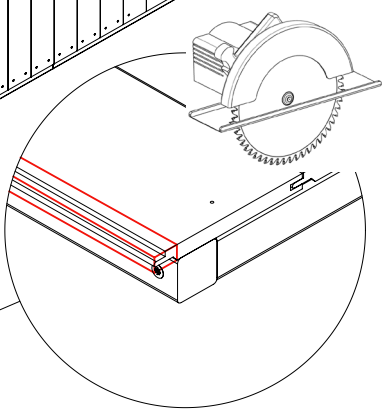
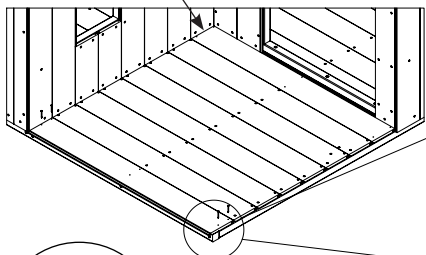

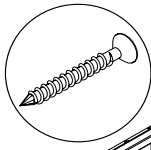
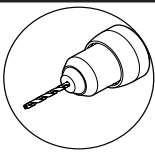

- 5 x 80mm x 3
- 5 x 100mm x 12

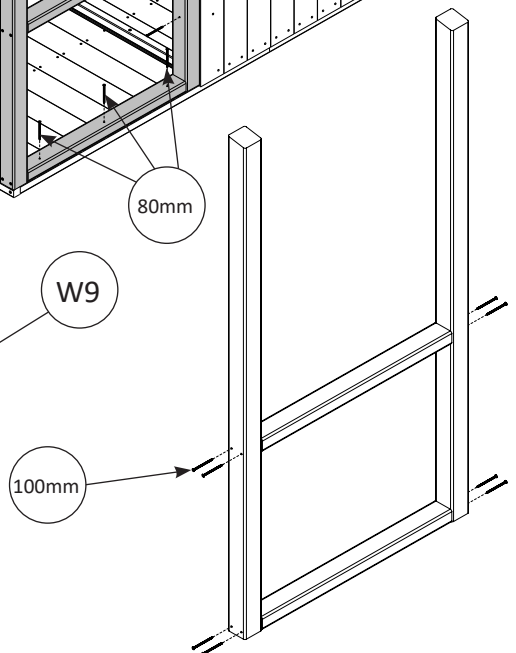
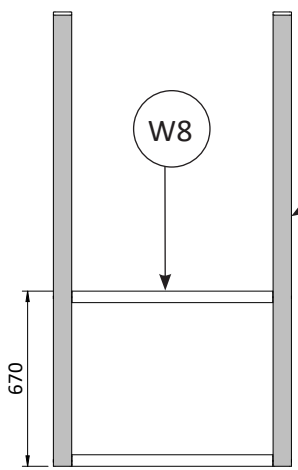
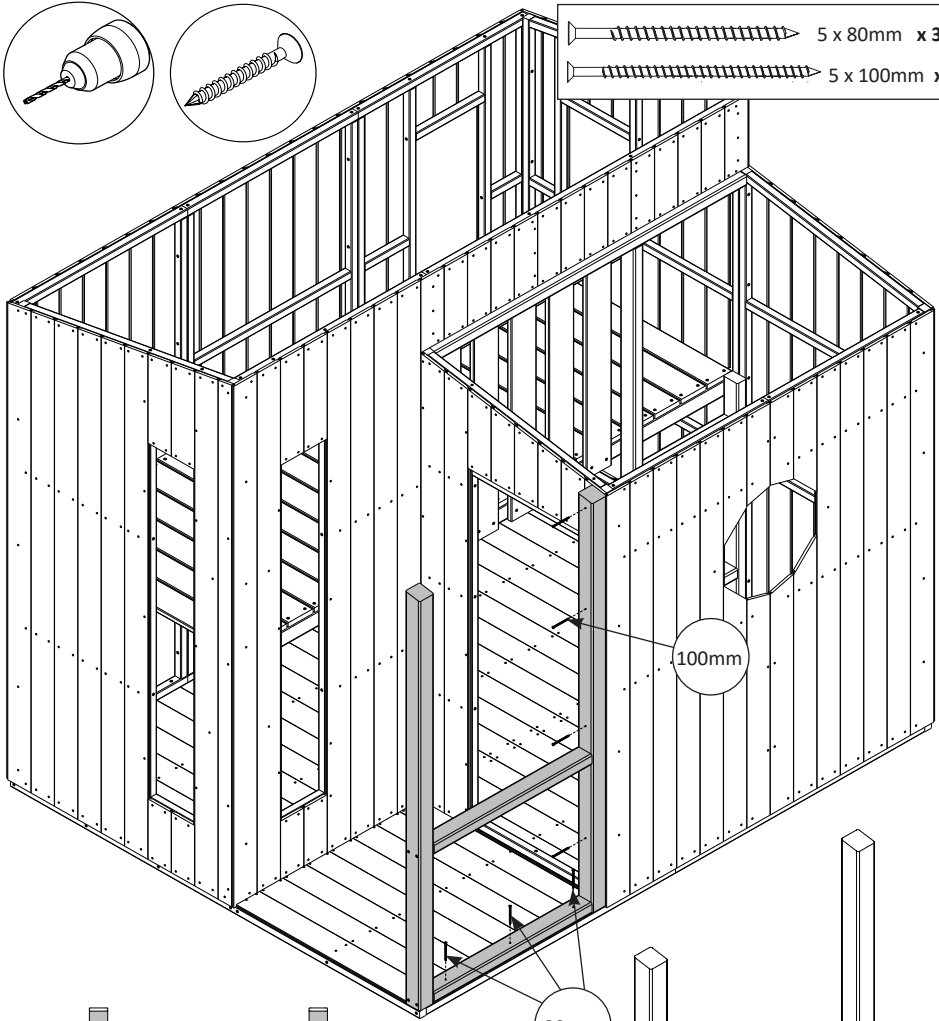

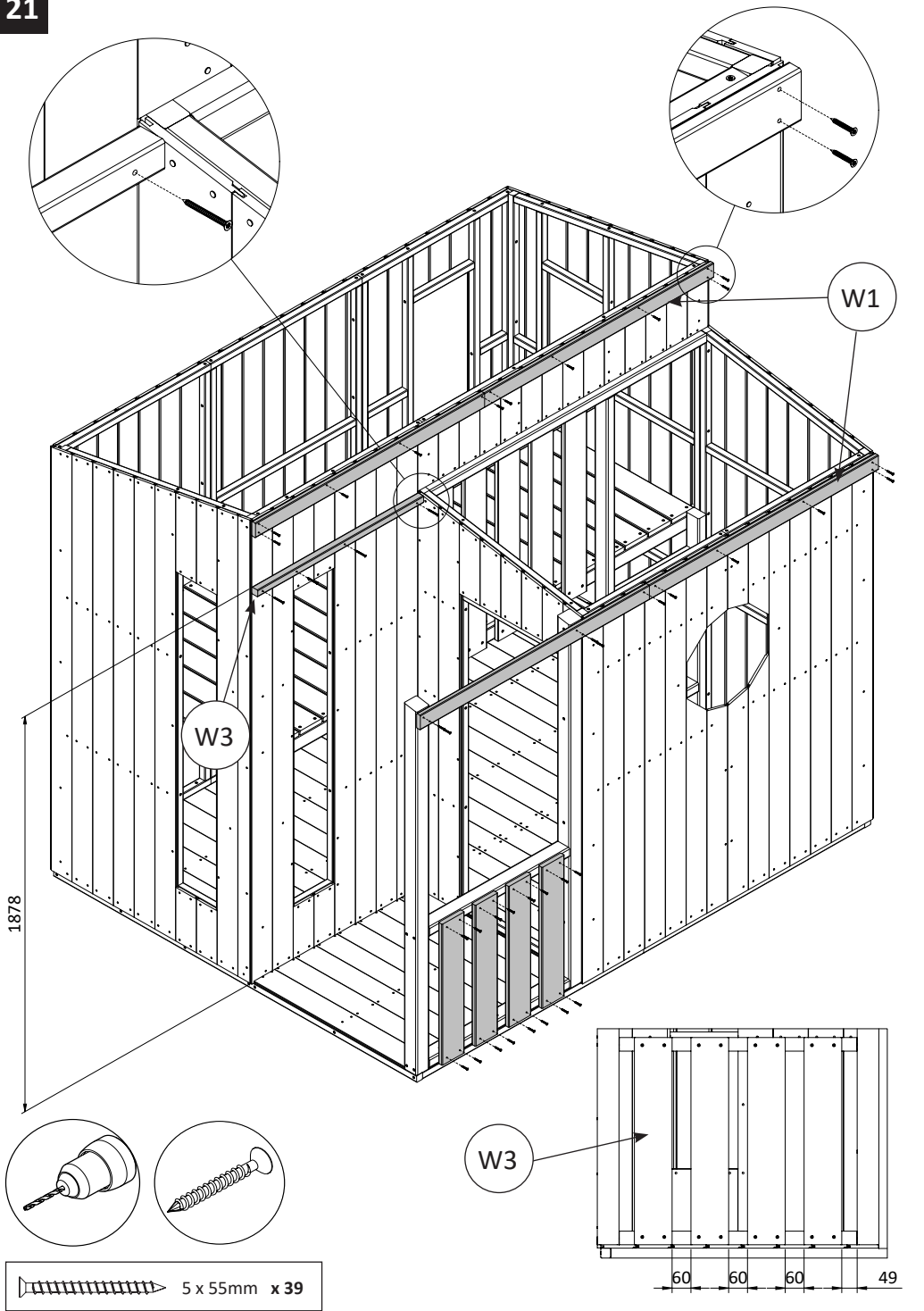

5 x 55mm x 10

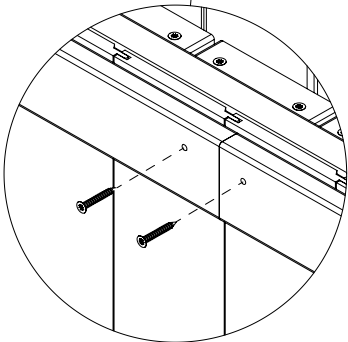
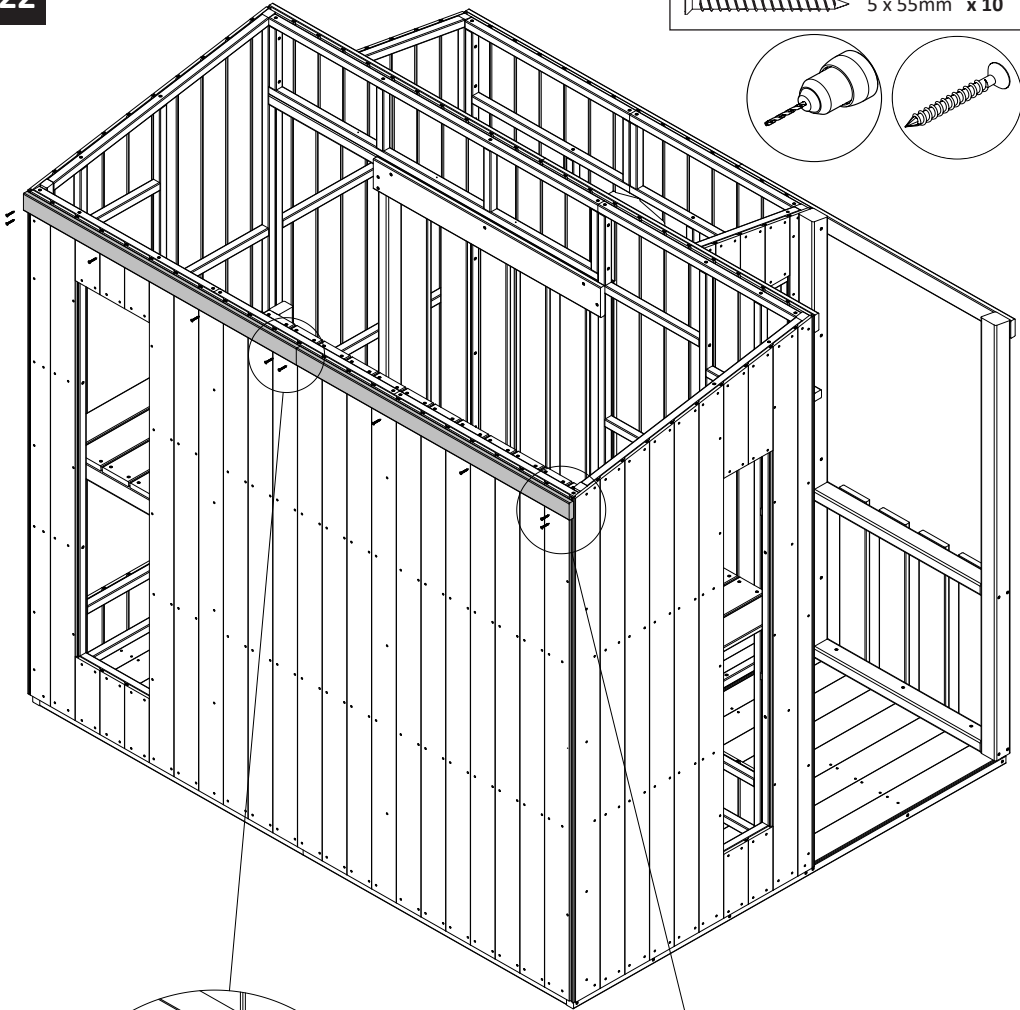
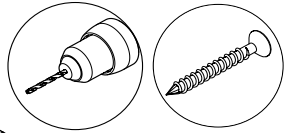

W1

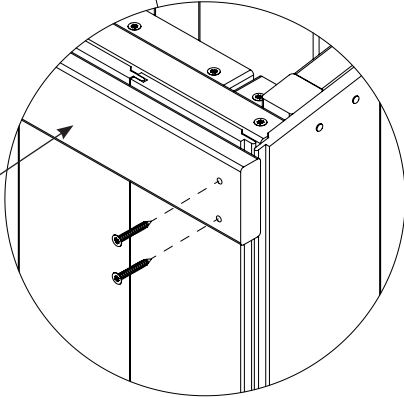

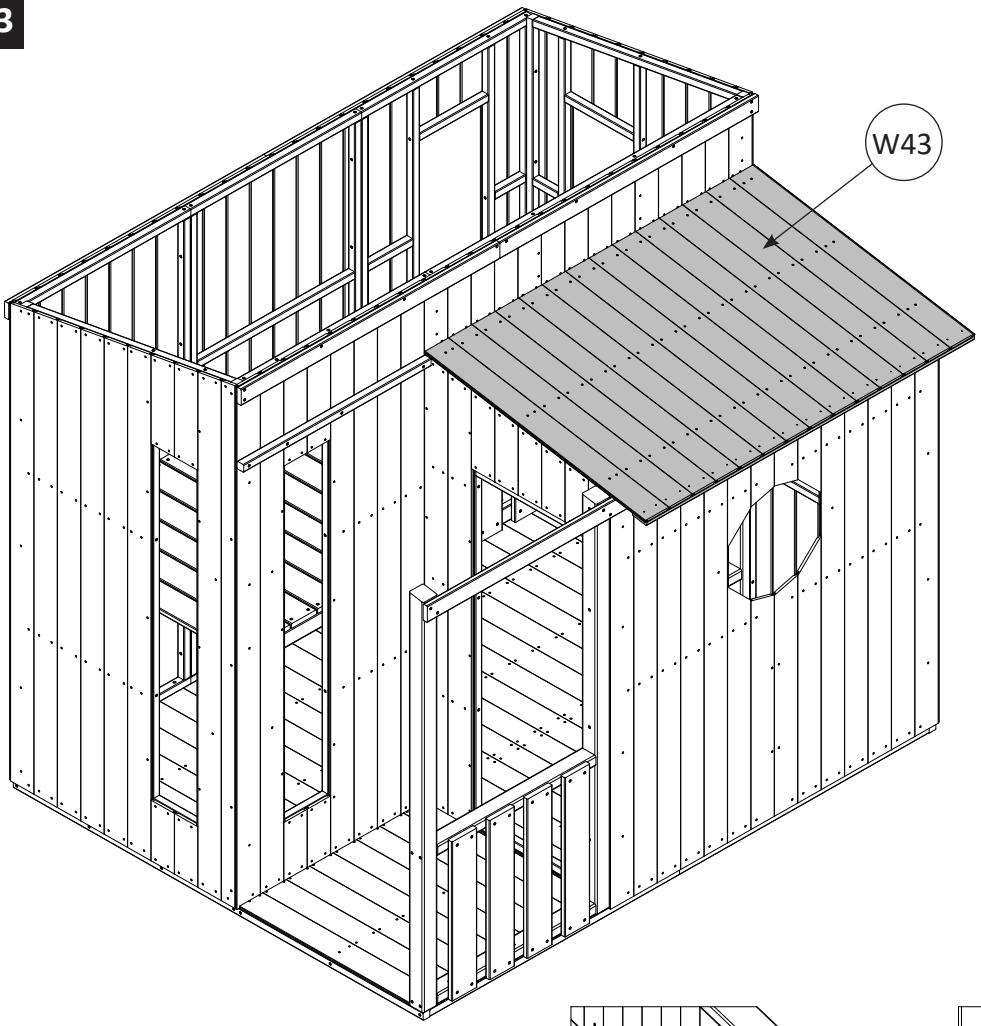

W43

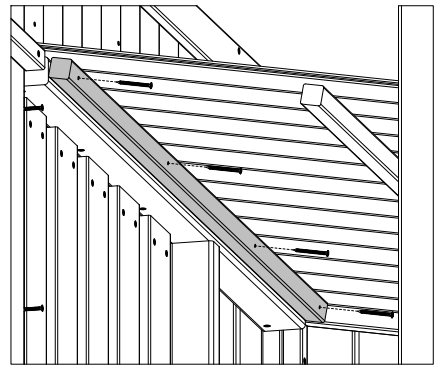
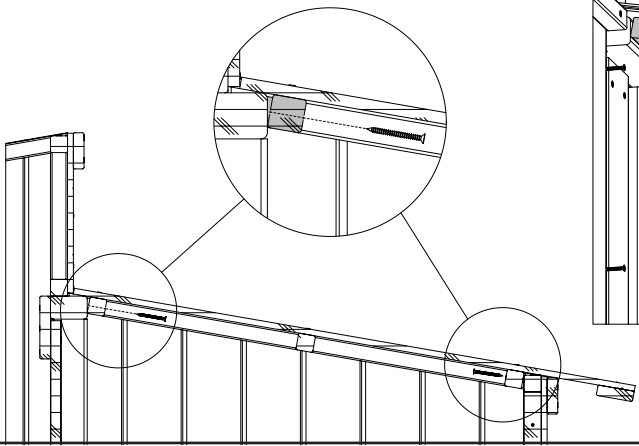

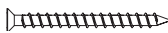
 5 x 55mm x 8

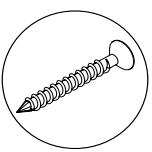
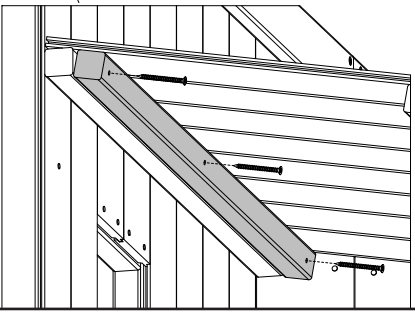
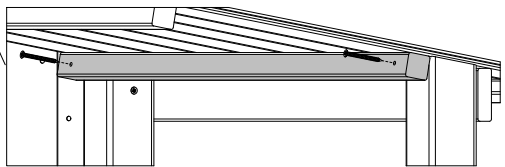
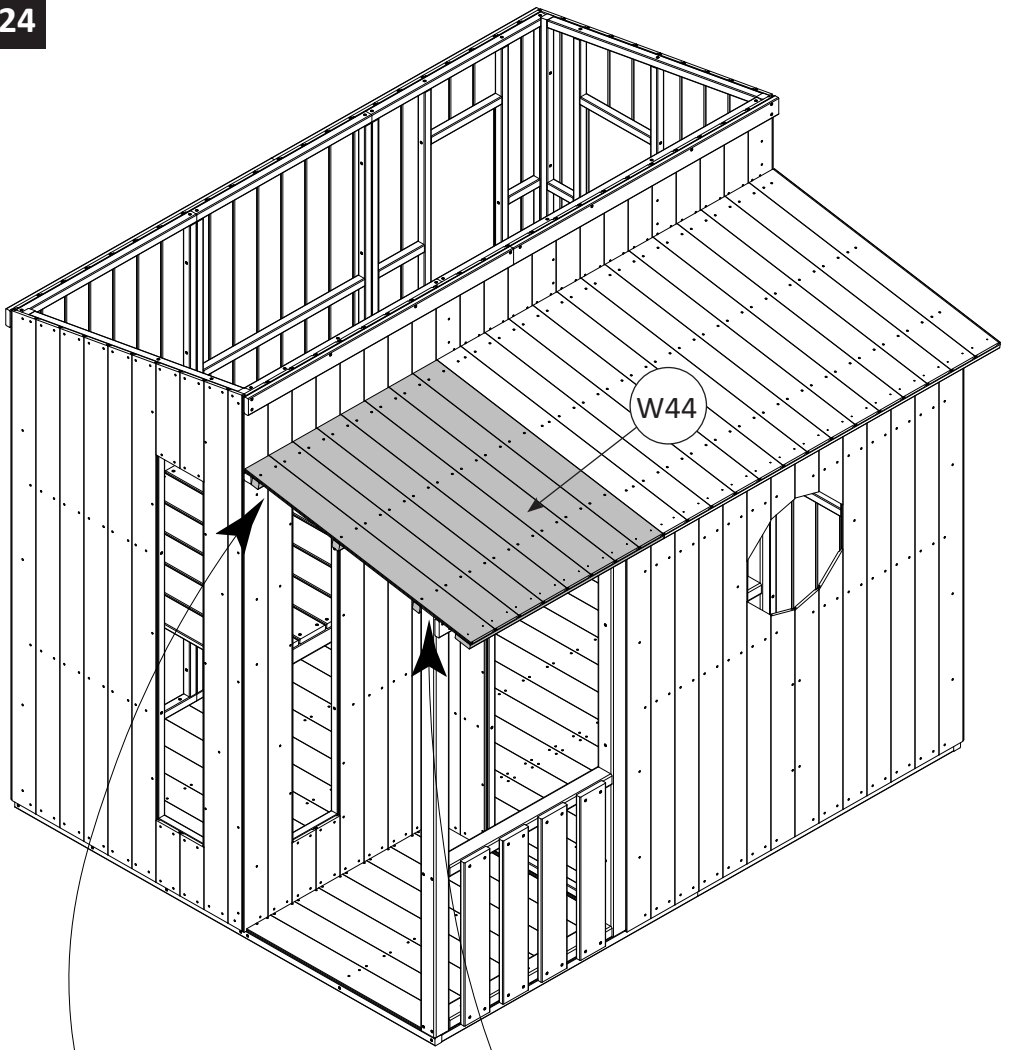

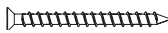
 5 x 55mm x 5

5 x 55mm x 12

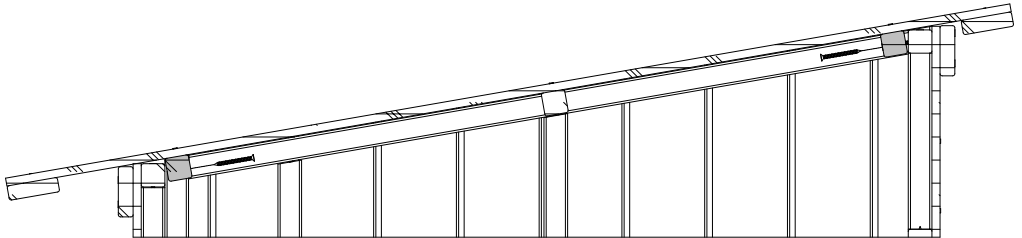
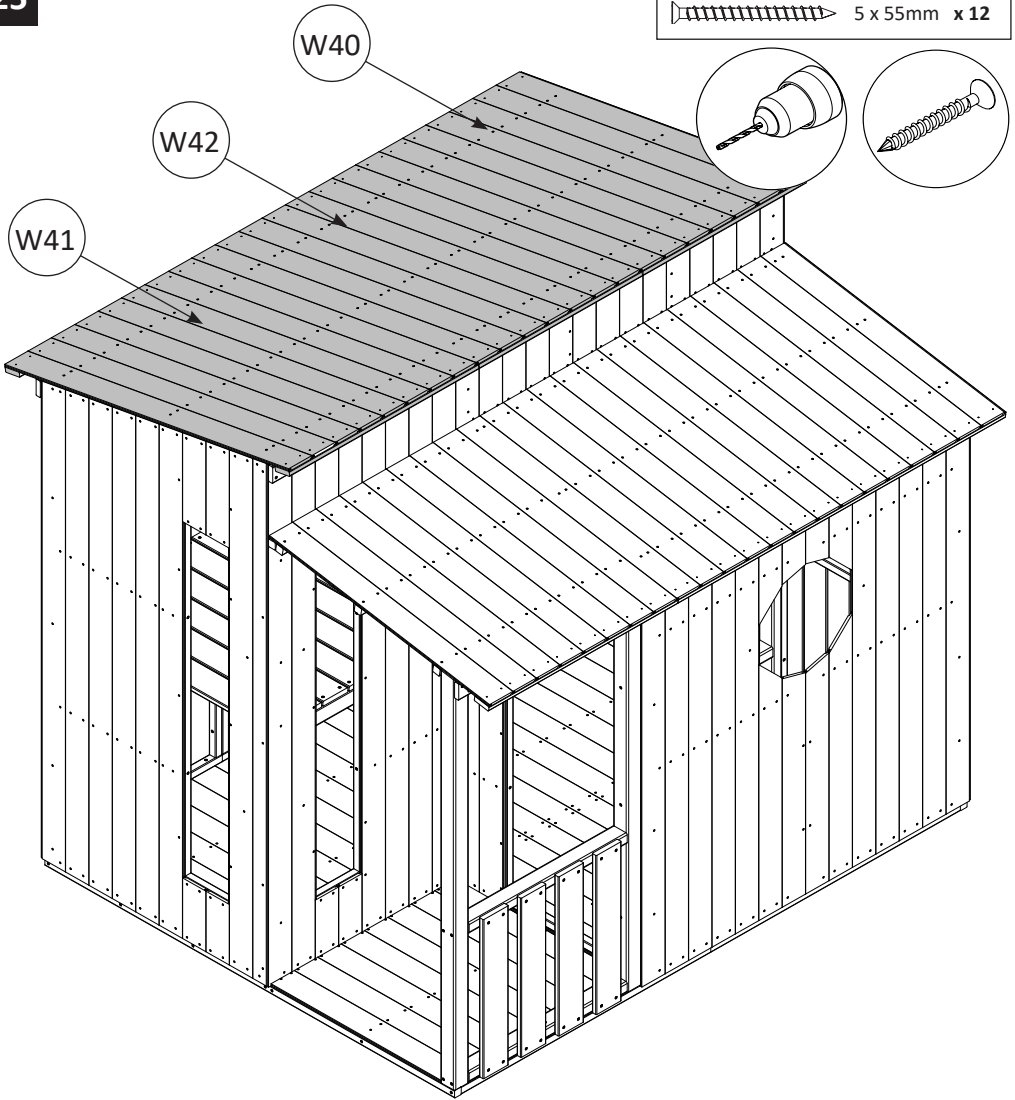

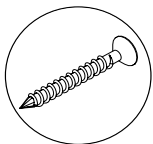
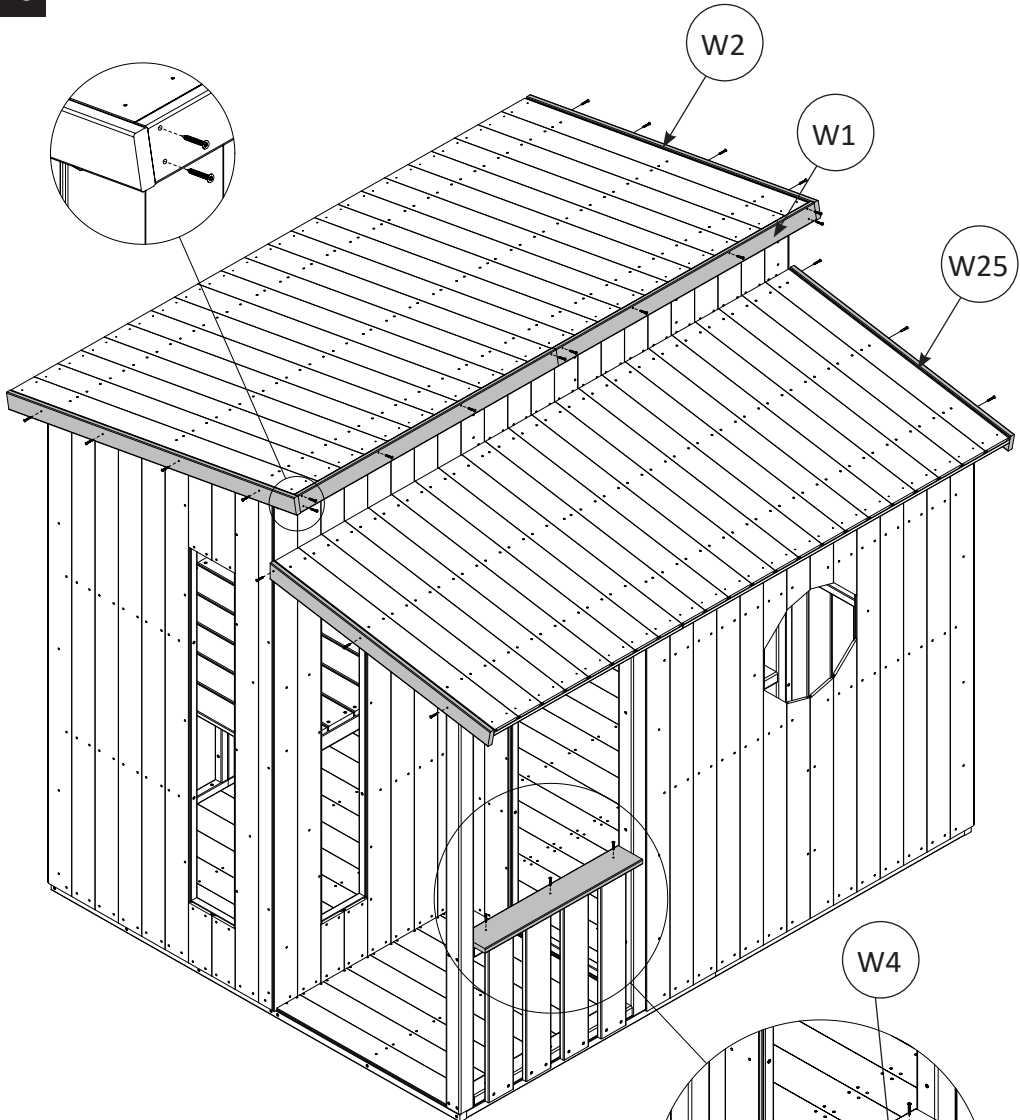

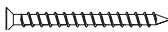
 5 x 55mm x 27

5 x 35mm x 40

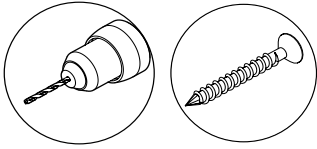

W28

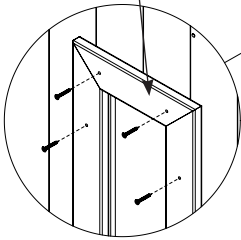

W46

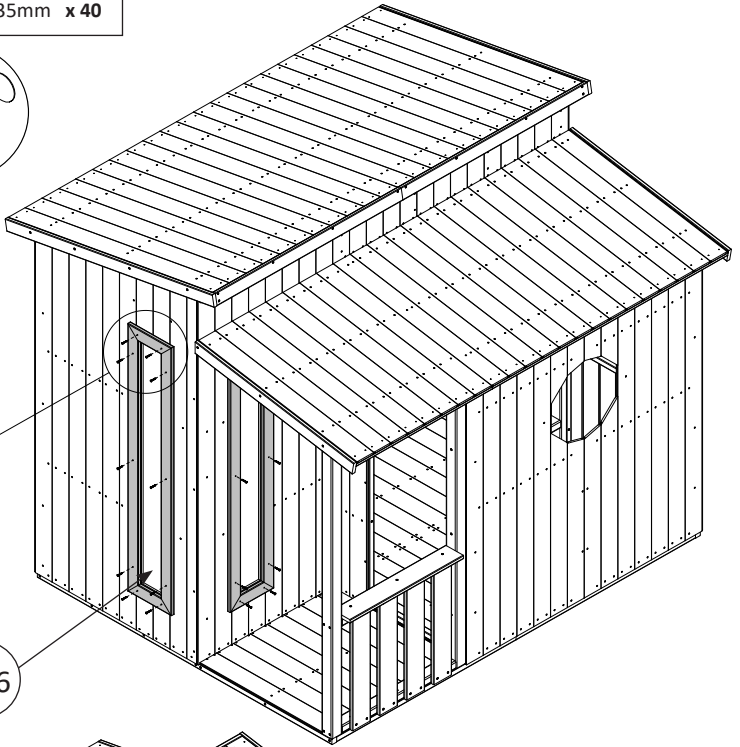

W26

W45

W27

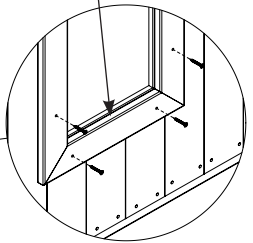

W48

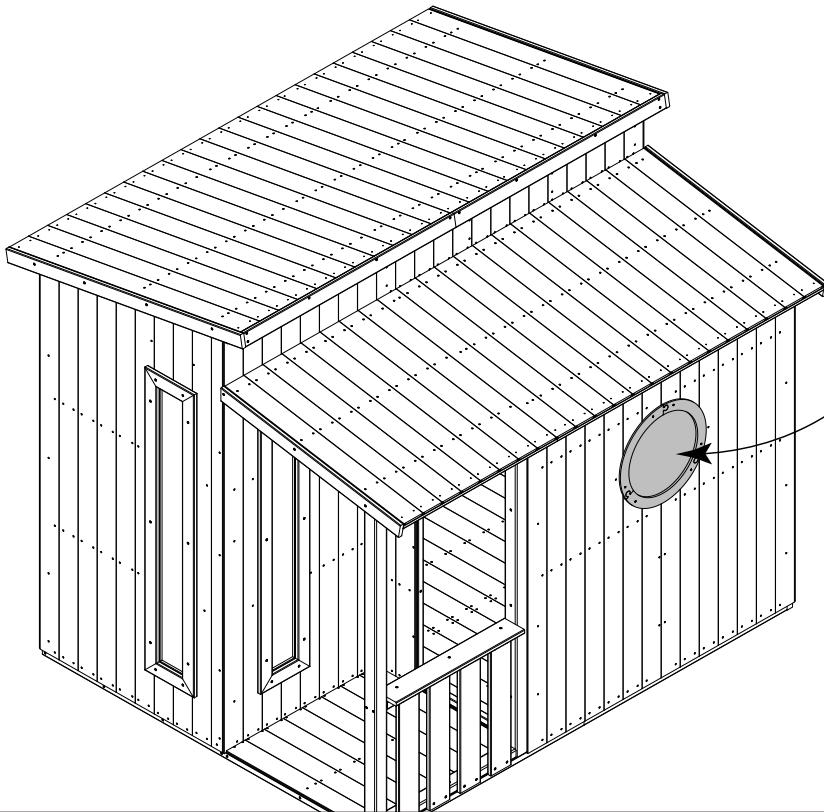
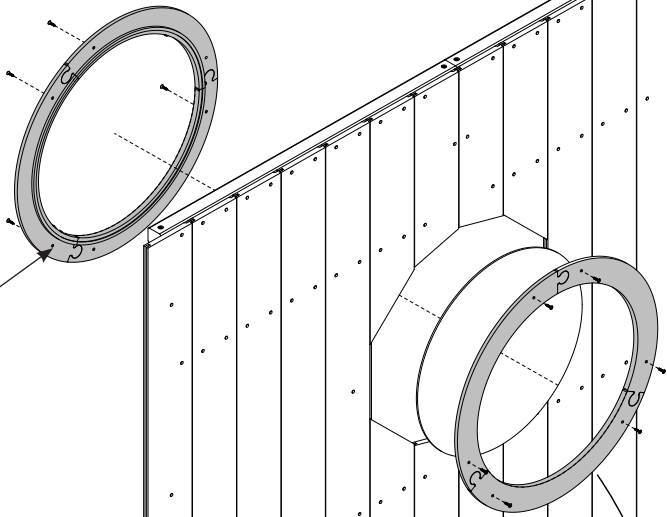

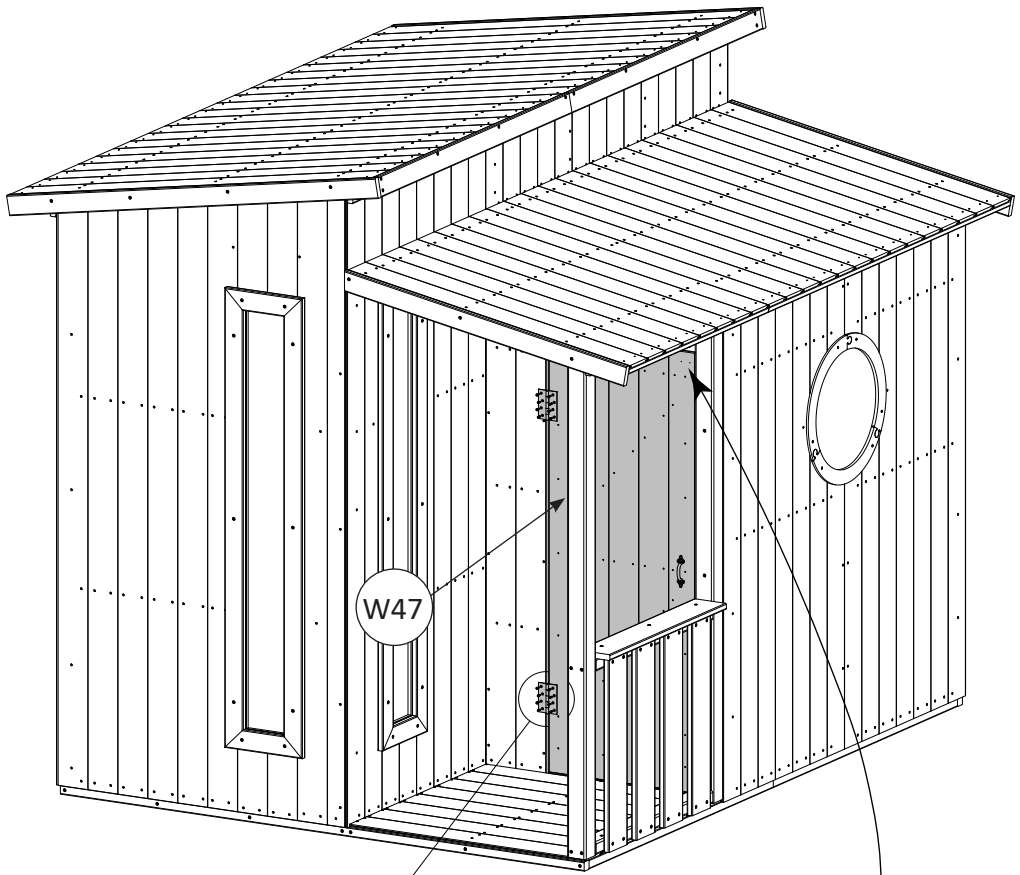

W47

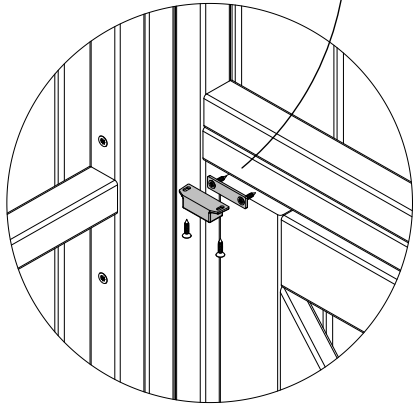
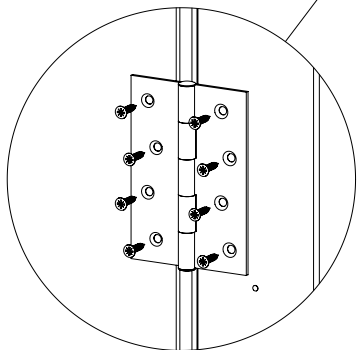

Polhus