

# Polhus

## SAUNA L1130 x 1900

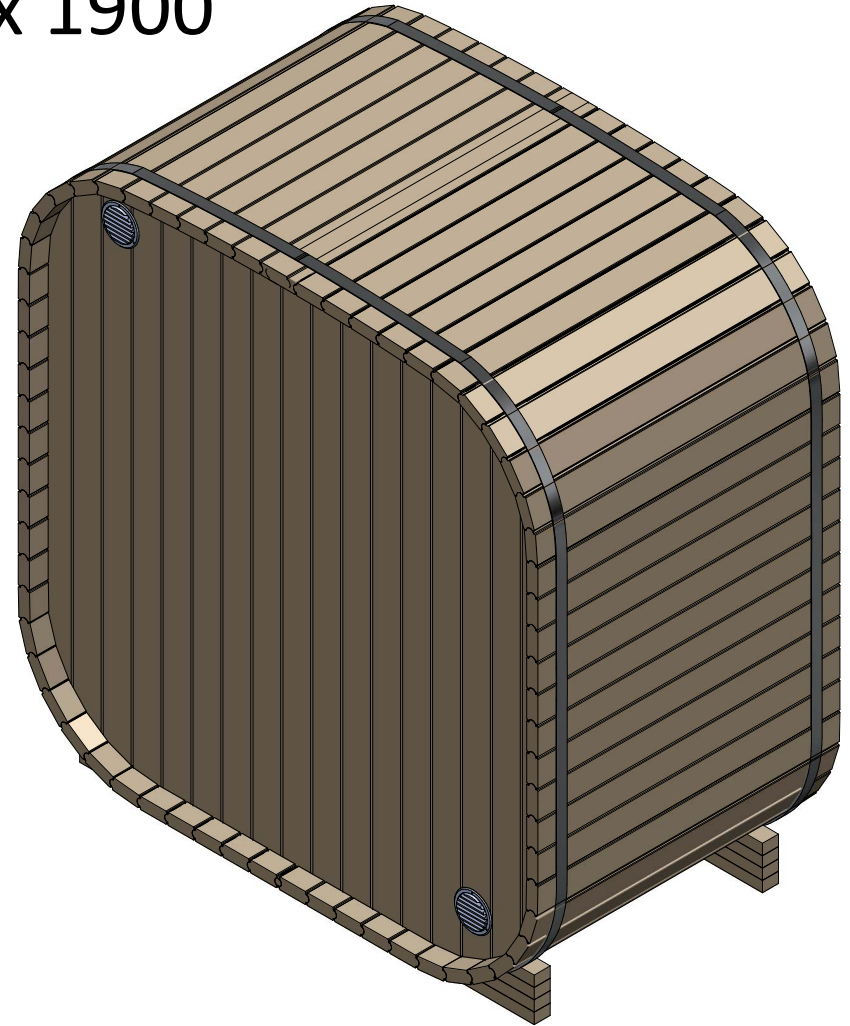

Before you start assembling the sauna, please read the entire manual.  
All units of measurement are in millimeters.  
A sauna barrel can never be 100% tight due to the construction.

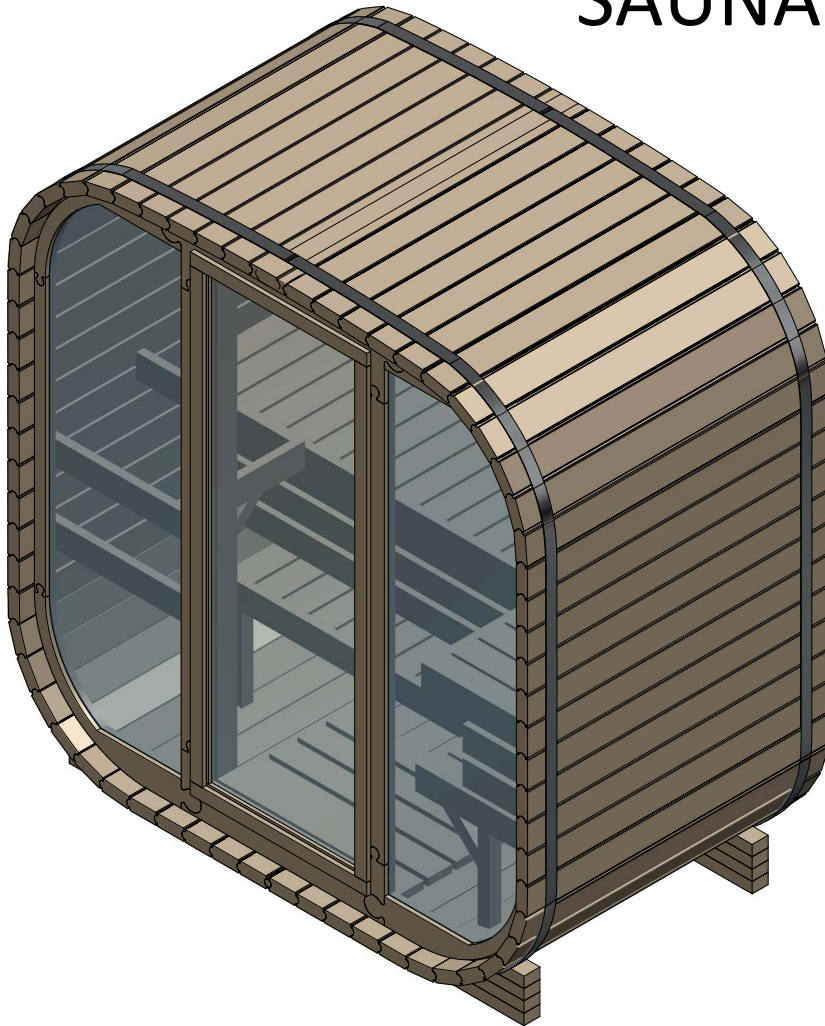





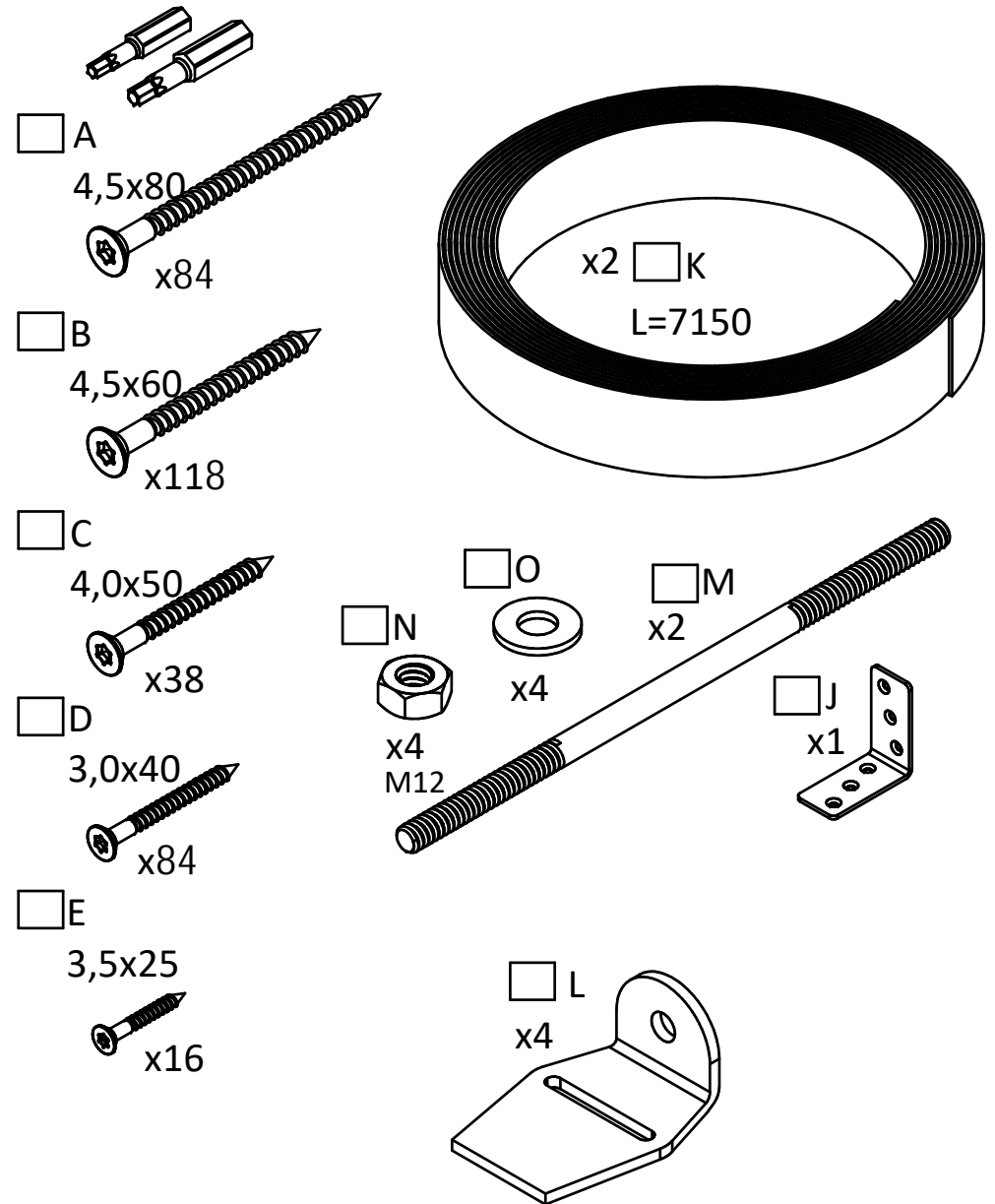
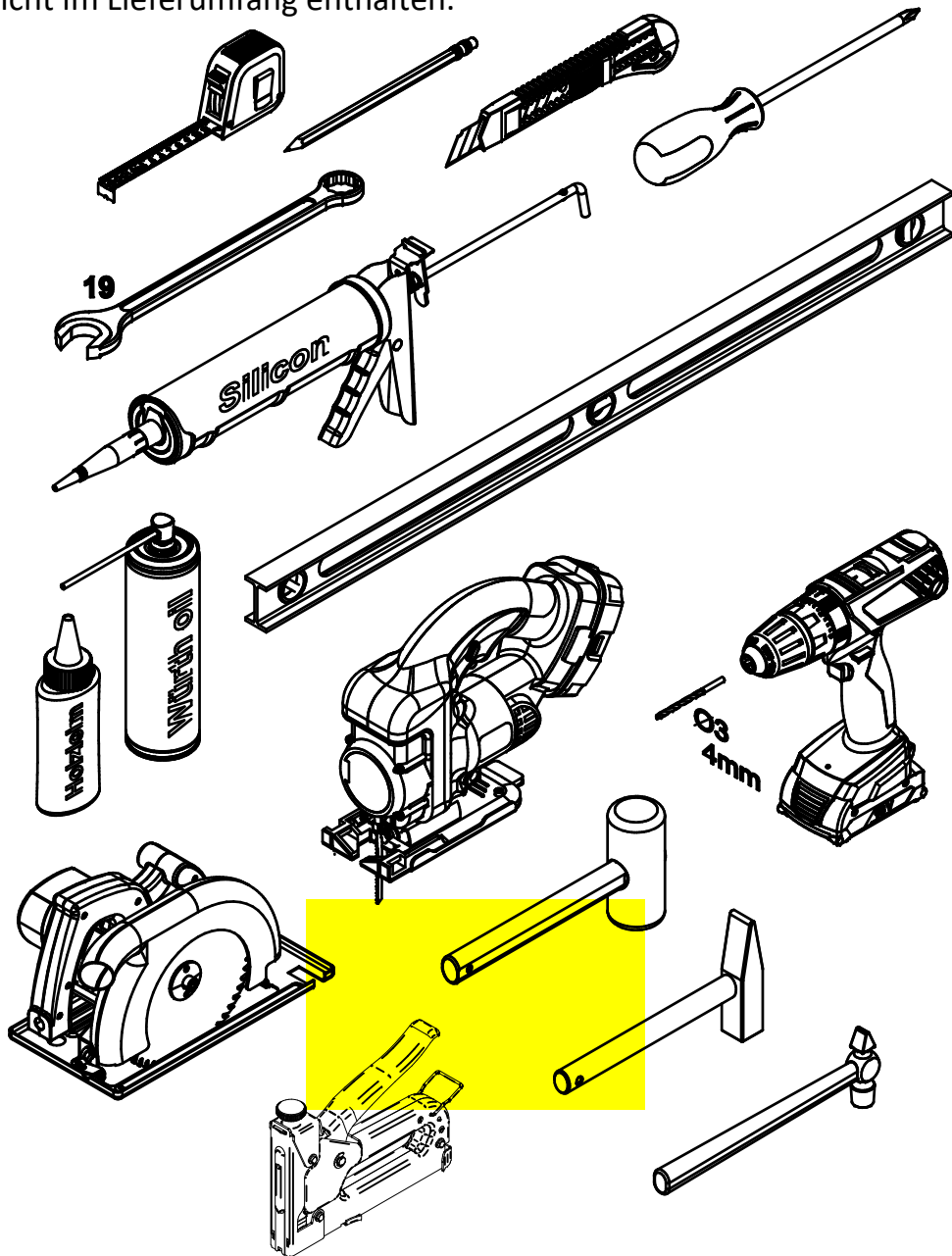





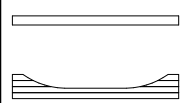

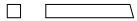
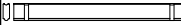

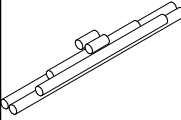
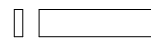
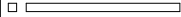



Bevor Sie mit der Saunamontage beginnen, lesen Sie bitte die ganze Anleitung durch.  
Alle Maßeinheiten sind in Millimeter angegeben.  
Ein Saunafass kann durch die Bauweise nie zu 100% dicht sein.

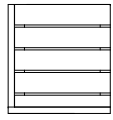
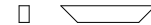

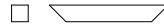
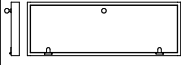





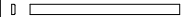



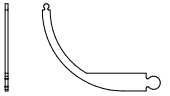

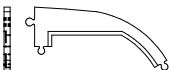

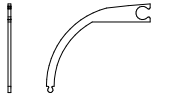
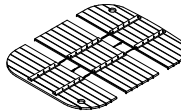

Serial no. : \_\_\_\_\_

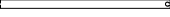
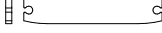
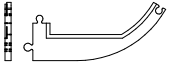
Tools that make your construction easier.  
 Not included in the delivery.  
 Werkzeuge, die Ihren Aufbau erleichtern.  
 Nicht im Lieferumfang enthalten.

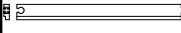

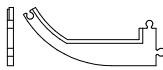

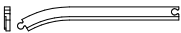
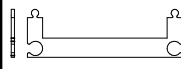

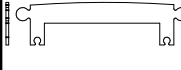
# BASE

No.	L x W x H	Qt		No.	L x W x H	Qt		No.	L x W x H	Qt	
1	1700x160x60	2		85a	400x302	1		94	372x44x44	1	
3	42x103x1130	68 +1		86	575x90x28	1		95	809x44x44	2	
21	D24	kit		87	396x90x28	3		96	813x44x44x2	2	
71	700x405	1		88	605x90x28	3		97	335x44x44	2	
81	1855x450x90	1		89	342x90x28	1		98	120x44x44	3	
82	480x450x90	1		90	300x40x28	1		99	60x28x28	10	
83	977x205x90	1		91	378x44x44	1		101	1690x590x100	1	
84	433x205x90	1		92	300x44x44	1		102	1670x45x15	2	
85	1485x414	1		93	250x44x44	3		103	660x45x15	2	

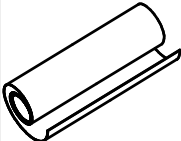
No.	L x W x H	Qt		No.	L x W x H	Qt		No.	L x W x H	Qt	
104	1690x28x28	2		626	Sperrholz Plywood 27mm	1		635	Sperrholz Plywood 15mm	2	
105	646x28x28	2		627	Sperrholz Plywood 27mm	1		636	Sperrholz Plywood 15mm	1	
161	Glas	2		628	Sperrholz Plywood 27mm	1		637	Sperrholz Plywood 15mm	1	
511	1955x1300x28	1		629	Sperrholz Plywood 27mm	1		638	Sperrholz Plywood 15mm	2	
621	Sperrholz Plywood 27mm	1		630	Sperrholz Plywood 27mm	1		901	Lüftungsgitter Air grille	3	
622	Sperrholz Plywood 27mm	1		631	Sperrholz Plywood 27mm	1		902	Lüftungsgitter Air Grille	1	
623	Sperrholz Plywood 27mm	1		632	Sperrholz Plywood 27mm	1					
624	Sperrholz Plywood 27mm	2		633	Sperrholz Plywood 15mm	2					
625	Sperrholz Plywood 27mm	1		634	Sperrholz Plywood 15mm	2					

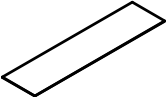
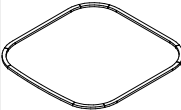
Optional

No.	L x W x H	Qt	
4	1130x44x44	2	
141	3600x1500	1	
142	L1000x320	43	
143	L1000x250	2	
151	Holz Arch	kit	
H	Nagel Nail	kit	
B	4,5x60	54	

# FOUNDATION PLAN FUNDAMENTPLAN

Use a spirit level  
Benutzen Sie eine Wasserwaage

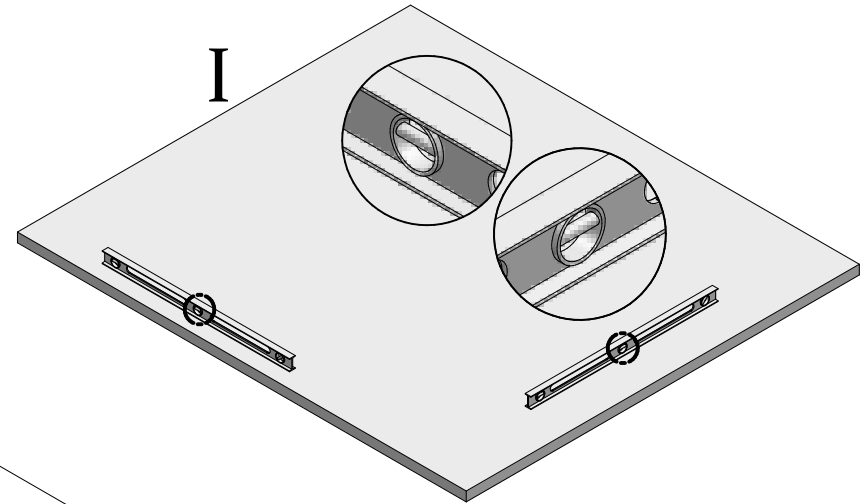

II

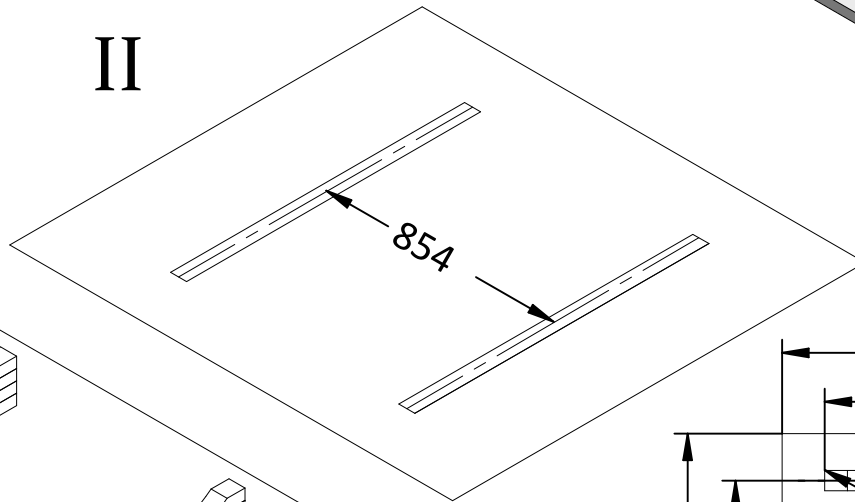

III

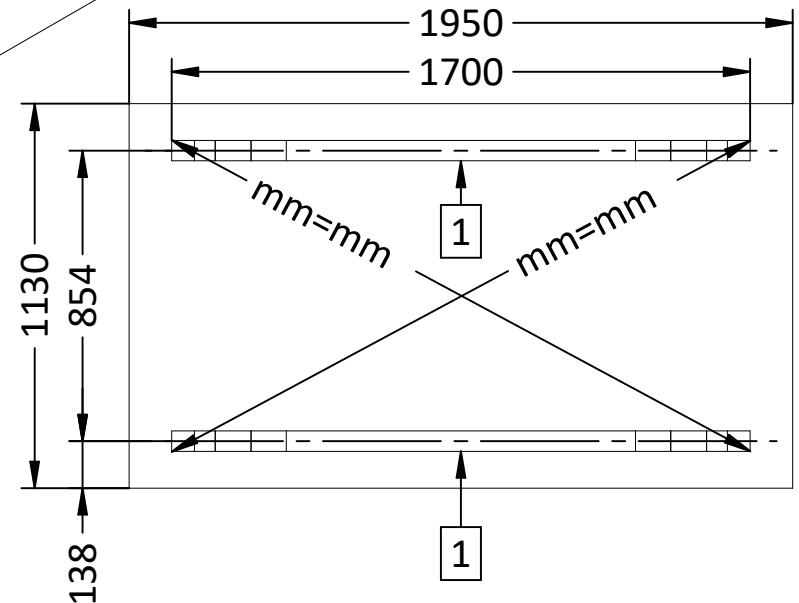
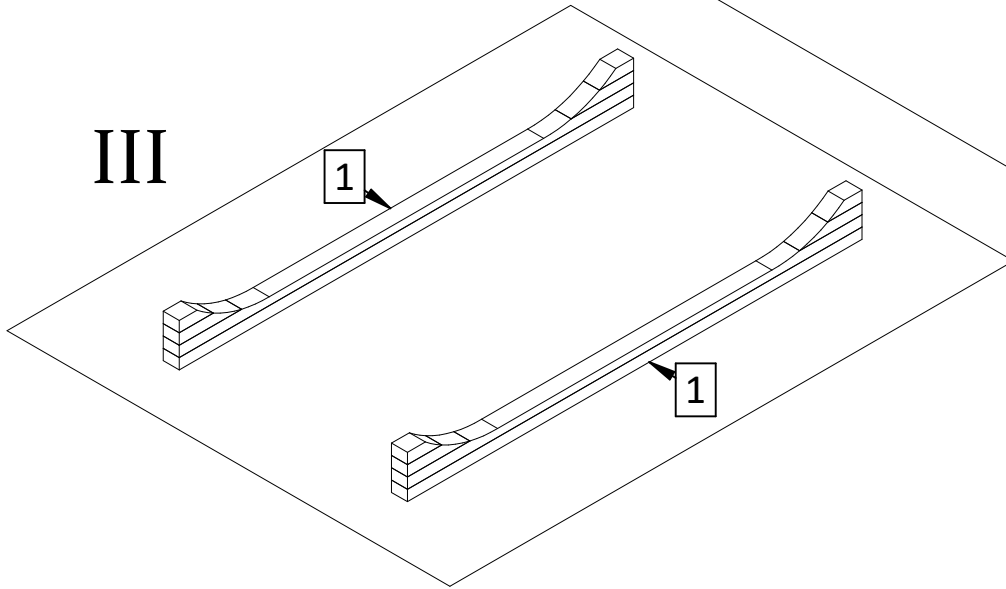

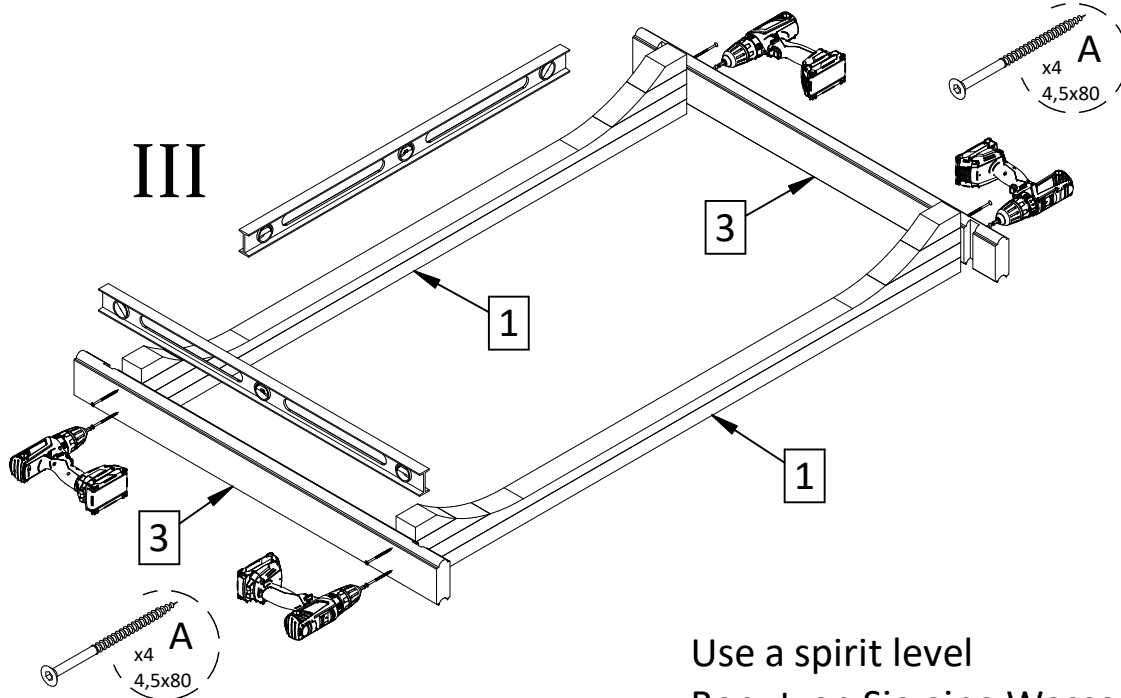
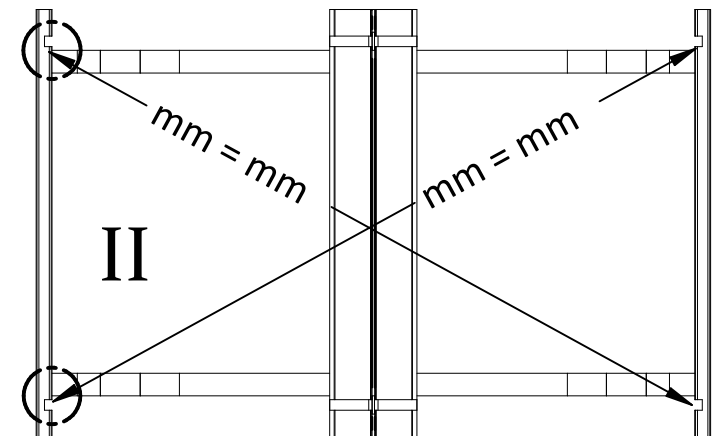
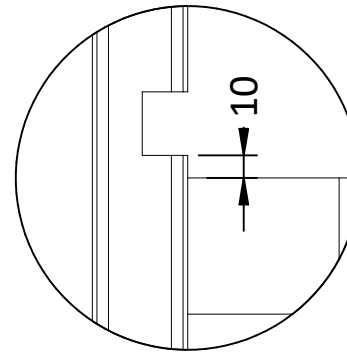
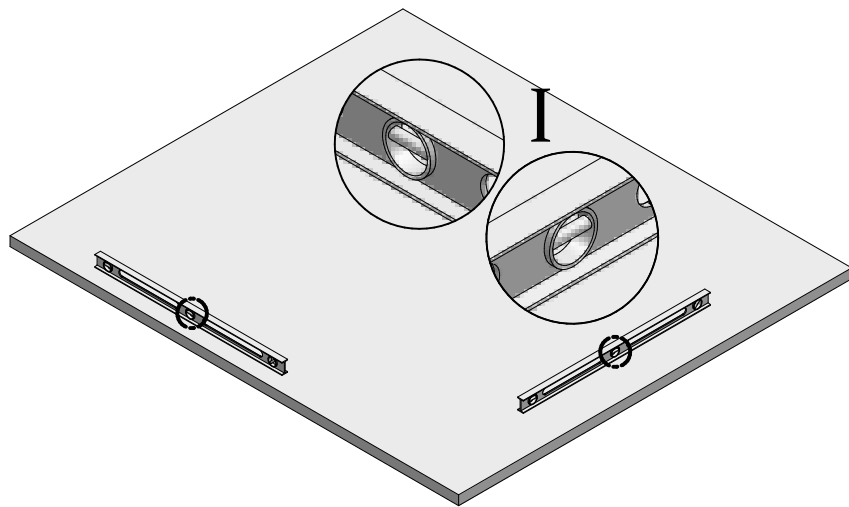

Use a spirit level  
Benutzen Sie eine Wasserwaage

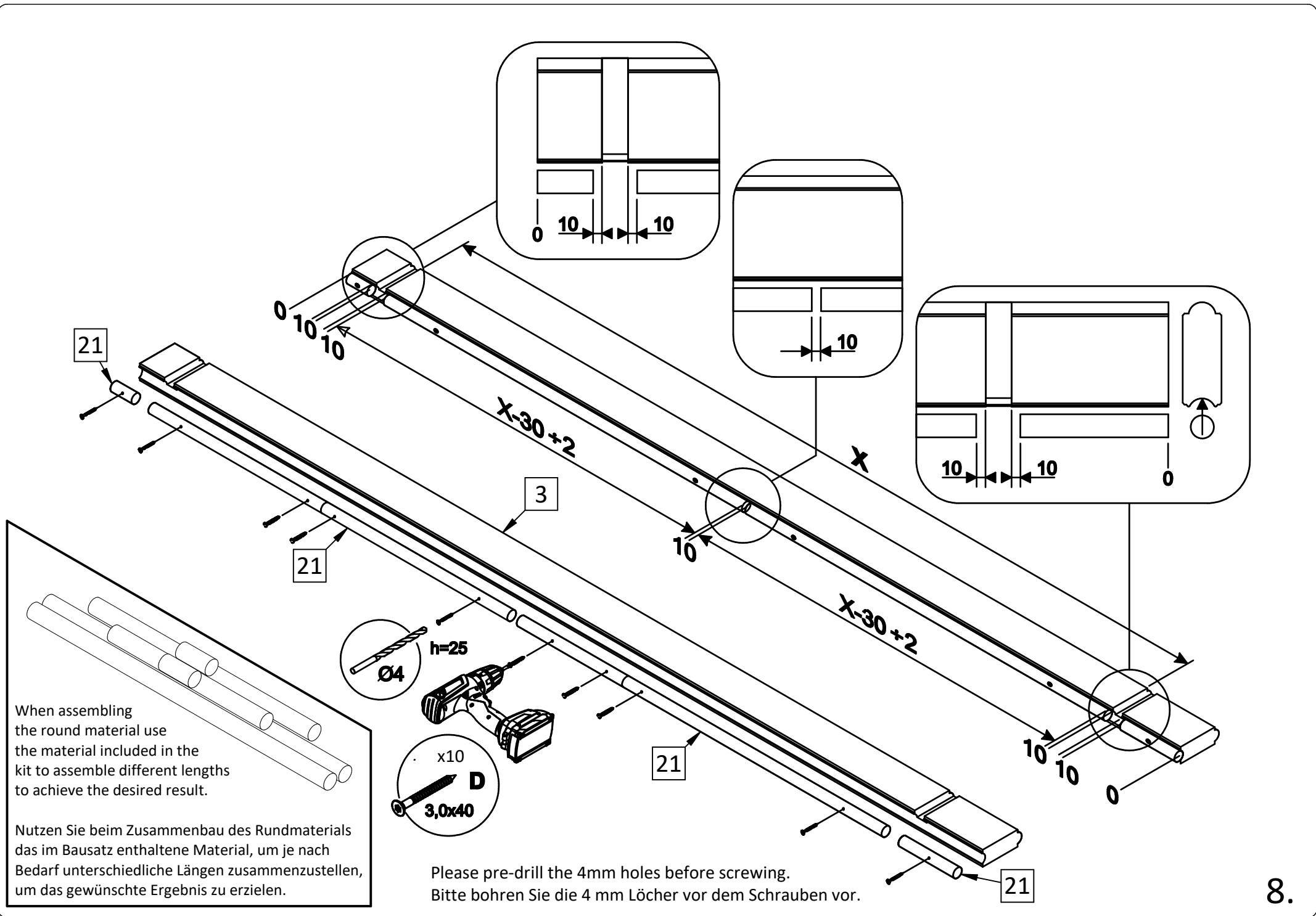

When assembling the round material use the material included in the kit to assemble different lengths to achieve the desired result.

Nutzen Sie beim Zusammenbau des Rundmaterials das im Bausatz enthaltene Material, um je nach Bedarf unterschiedliche Längen zusammenzustellen, um das gewünschte Ergebnis zu erzielen.

Please pre-drill the 4mm holes before screwing.  
Bitte bohren Sie die 4 mm Löcher vor dem Schrauben vor.



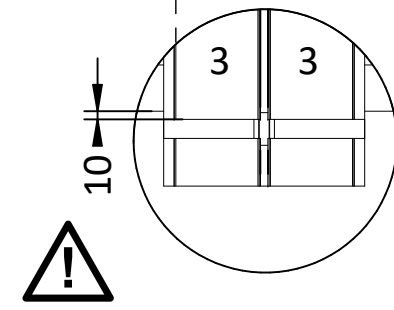
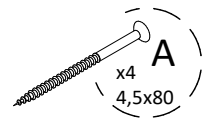
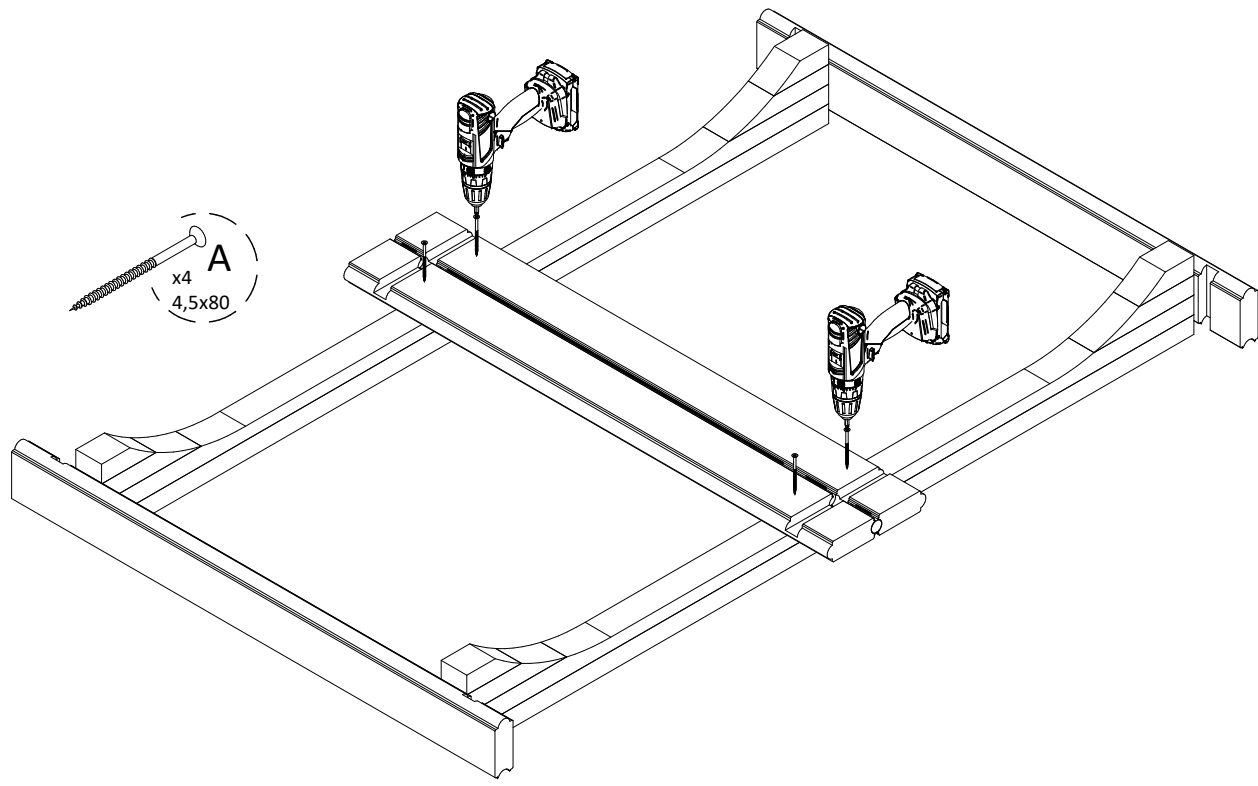
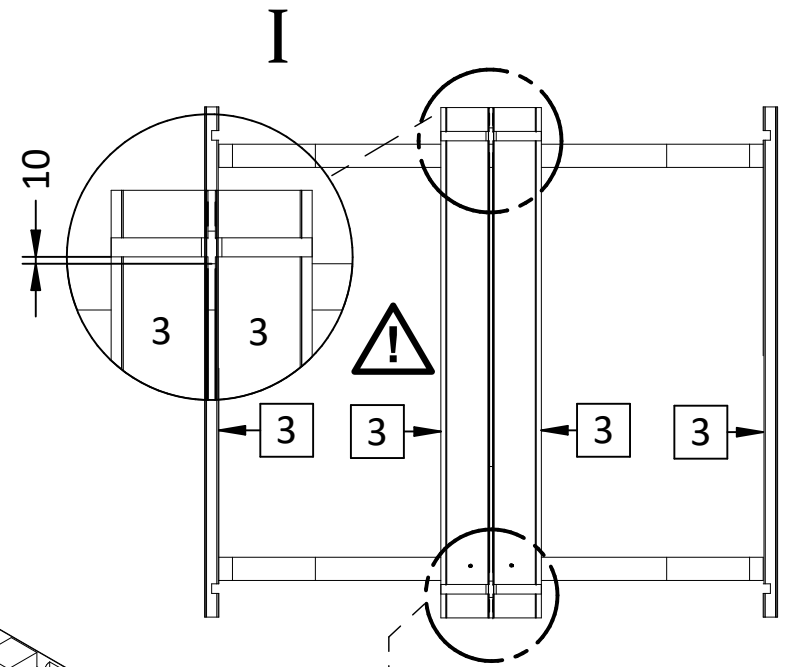
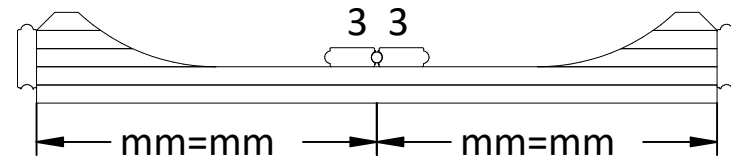
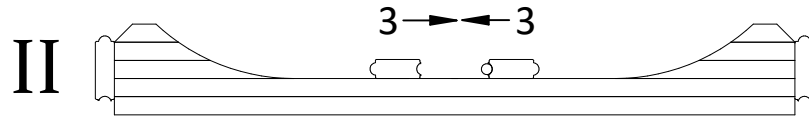

Use a spirit level  
Benutzen Sie eine Wasserwaage

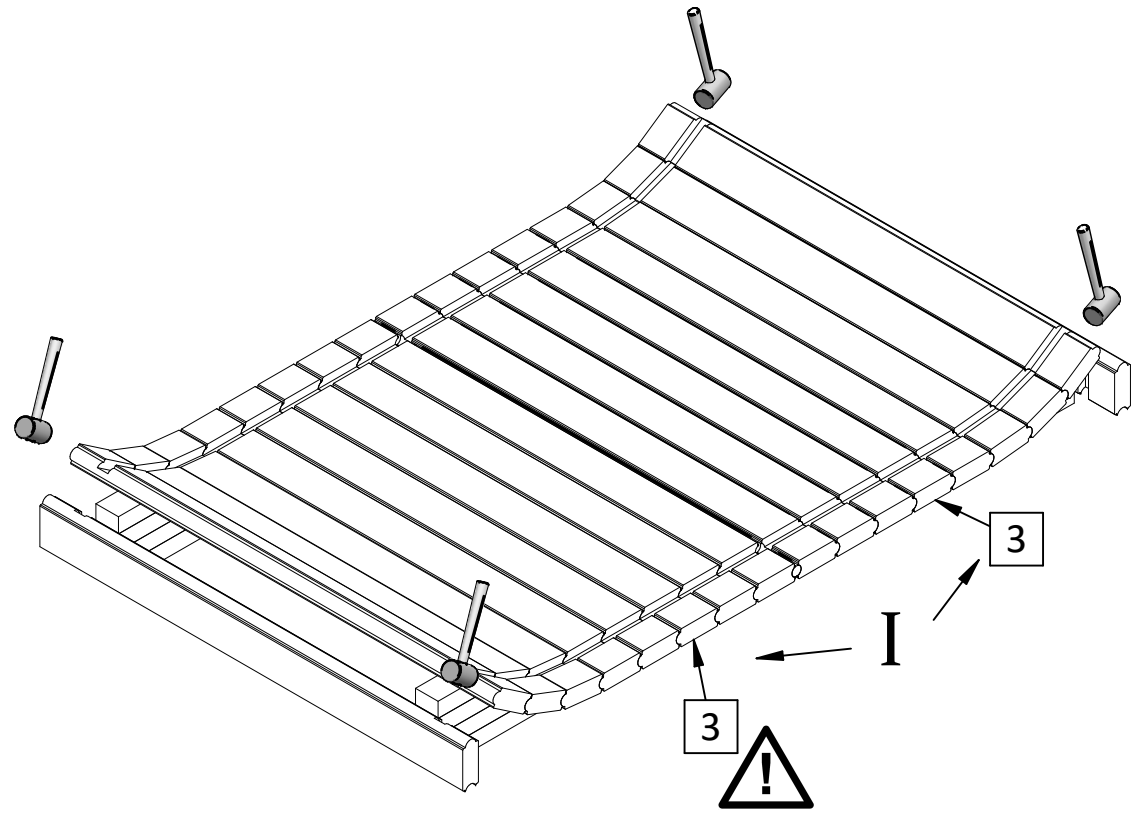
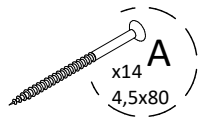
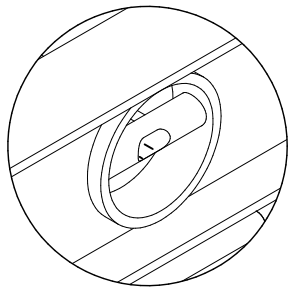

3

3

I

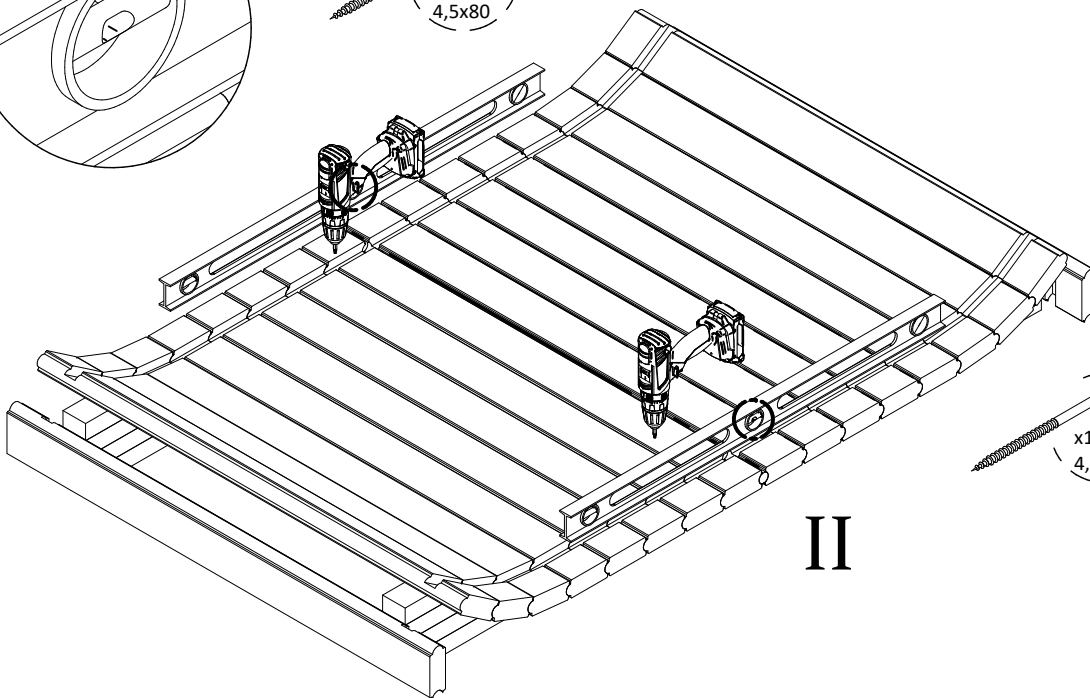
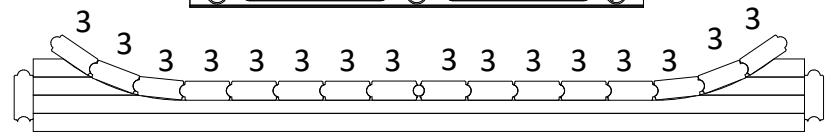

II

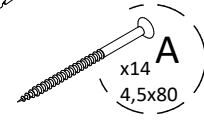

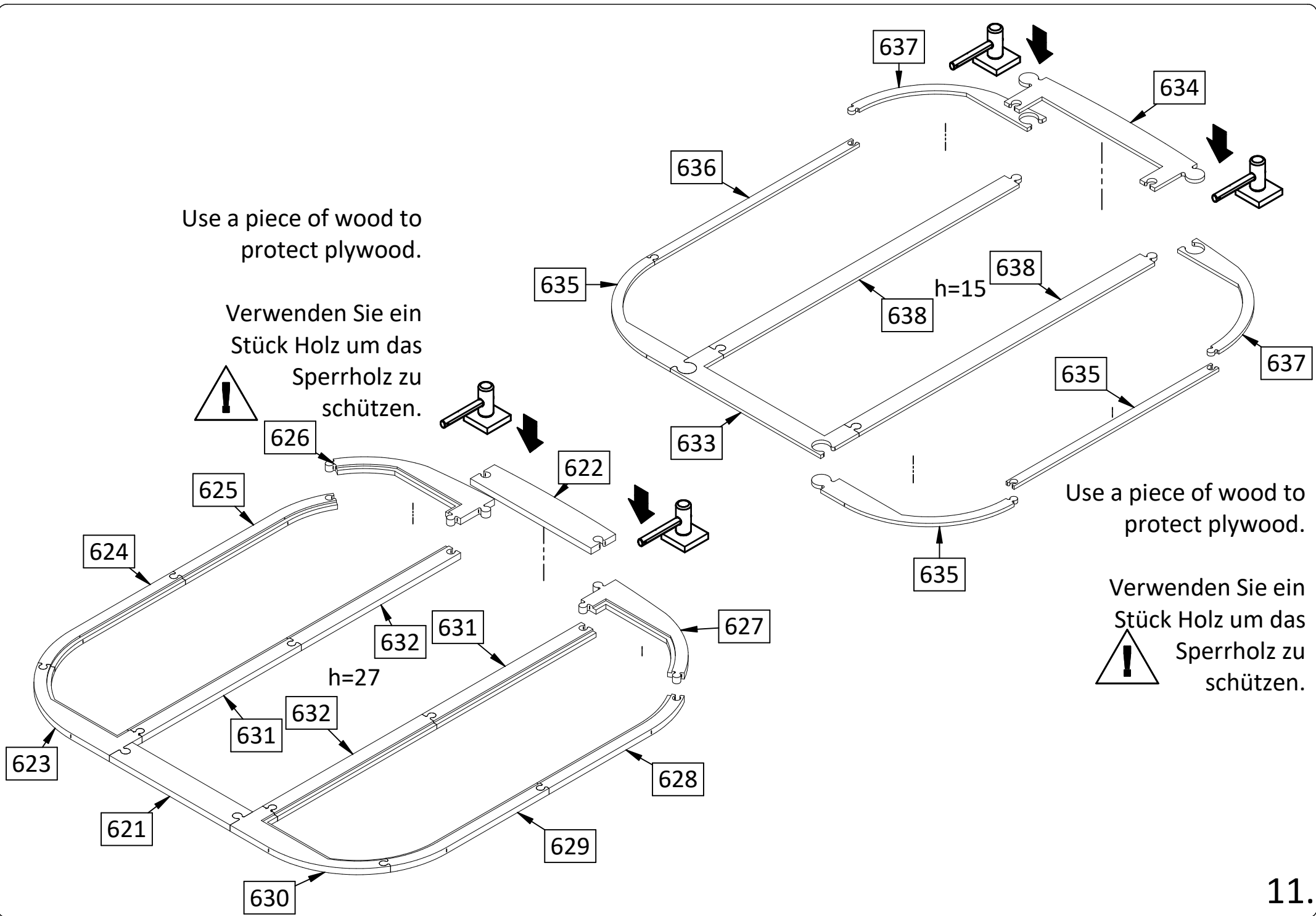

Use a piece of wood to protect plywood.

Verwenden Sie ein Stück Holz um das Sperrholz zu schützen.



Use a piece of wood to protect plywood.

Verwenden Sie ein Stück Holz um das Sperrholz zu schützen.



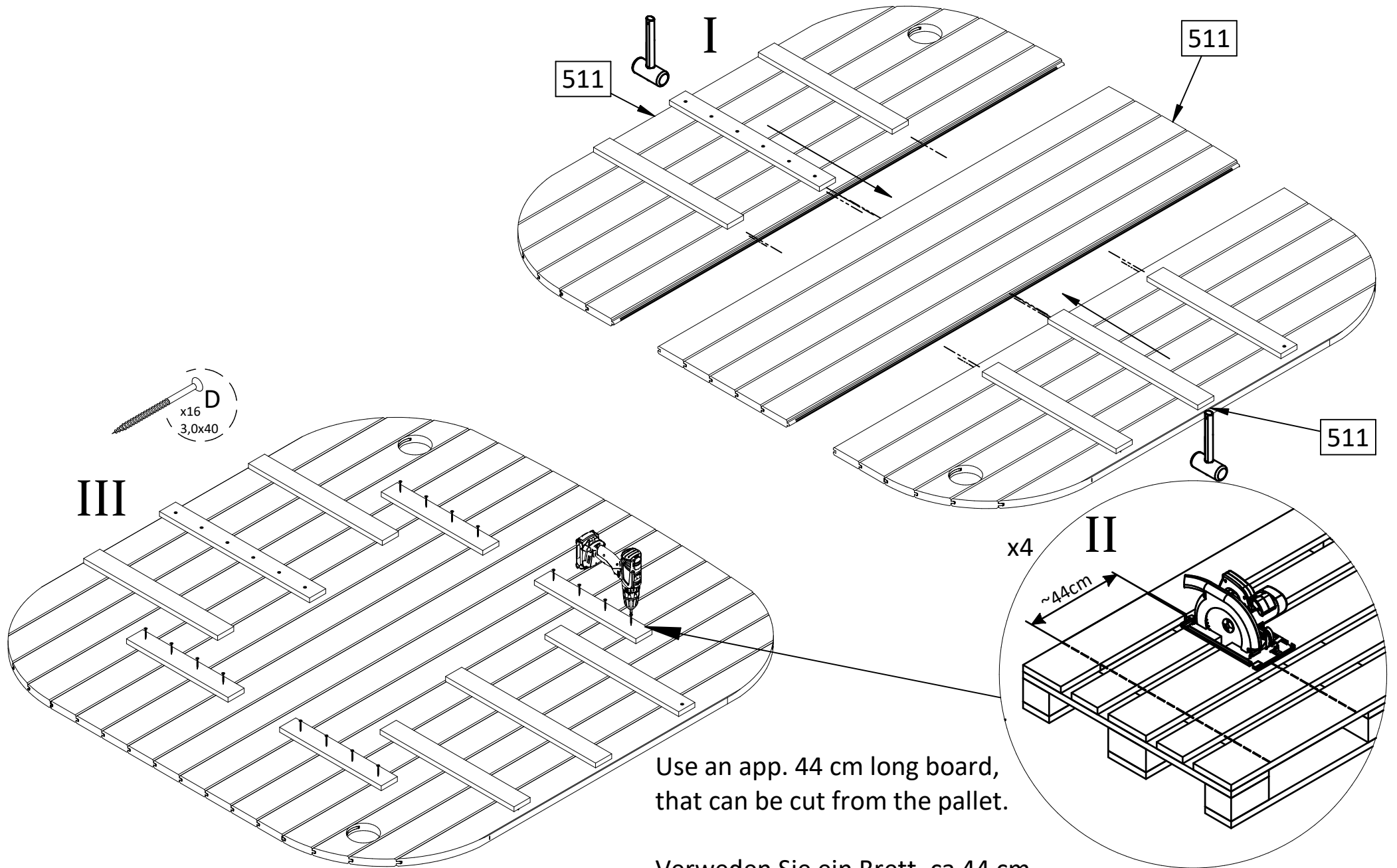

Use an app. 44 cm long board,  
that can be cut from the pallet.

Verwenden Sie ein Brett, ca 44 cm,  
das von der Palette abgeschnitten  
werden kann.

Use a spirit level  
Benutzen Sie eine Wasserwaage

II

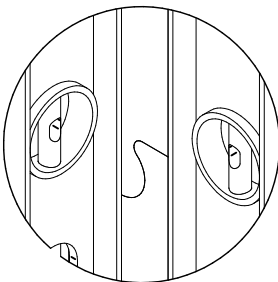

621-632

Important! Keep your distance!  
Don't leave a gap if  
the sauna is made of  
thermowood.



Wichtig! Abstand halten!  
Keine Lücke lassen,  
falls Sauna aus Thermoholz ist.

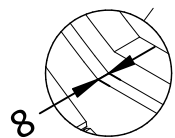

~7 mm

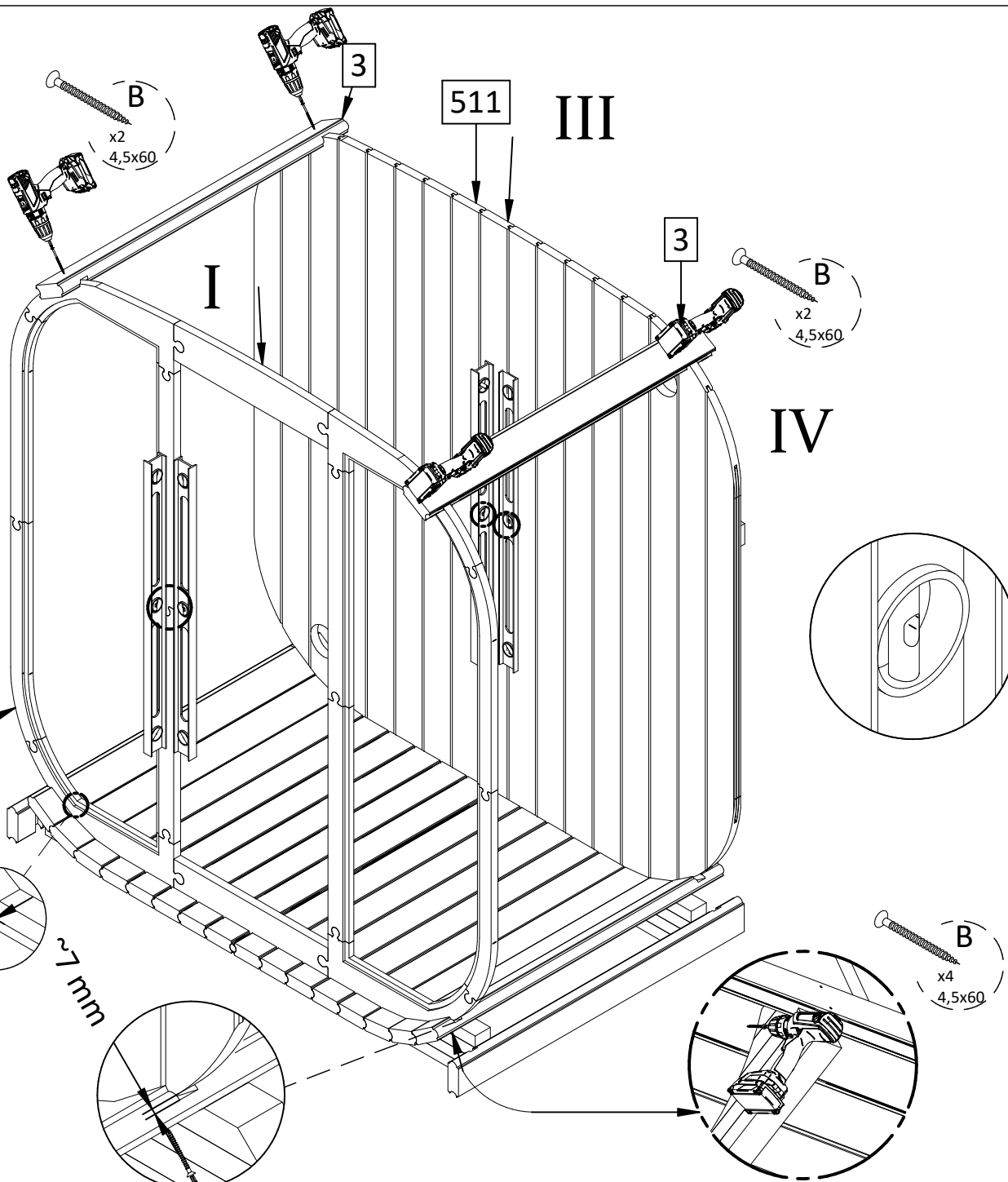
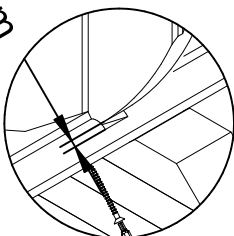

Important! Keep your distance!  
Don't leave a gap if  
the sauna is made of  
thermowood.

Wichtig! Abstand halten!  
Keine Lücke lassen,  
falls Sauna aus  
Thermoholz ist.

Important! Please remove  
the screws and use them  
for further assembly.

Wichtig! Bitte entfernen Sie  
die Schrauben und benutzen sie  
die bei der weiteren Montage

Remove the screws.  
Die Schrauben entfernen.

Remove the screws.  
Die Schrauben entfernen.

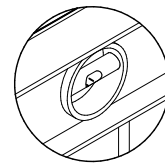
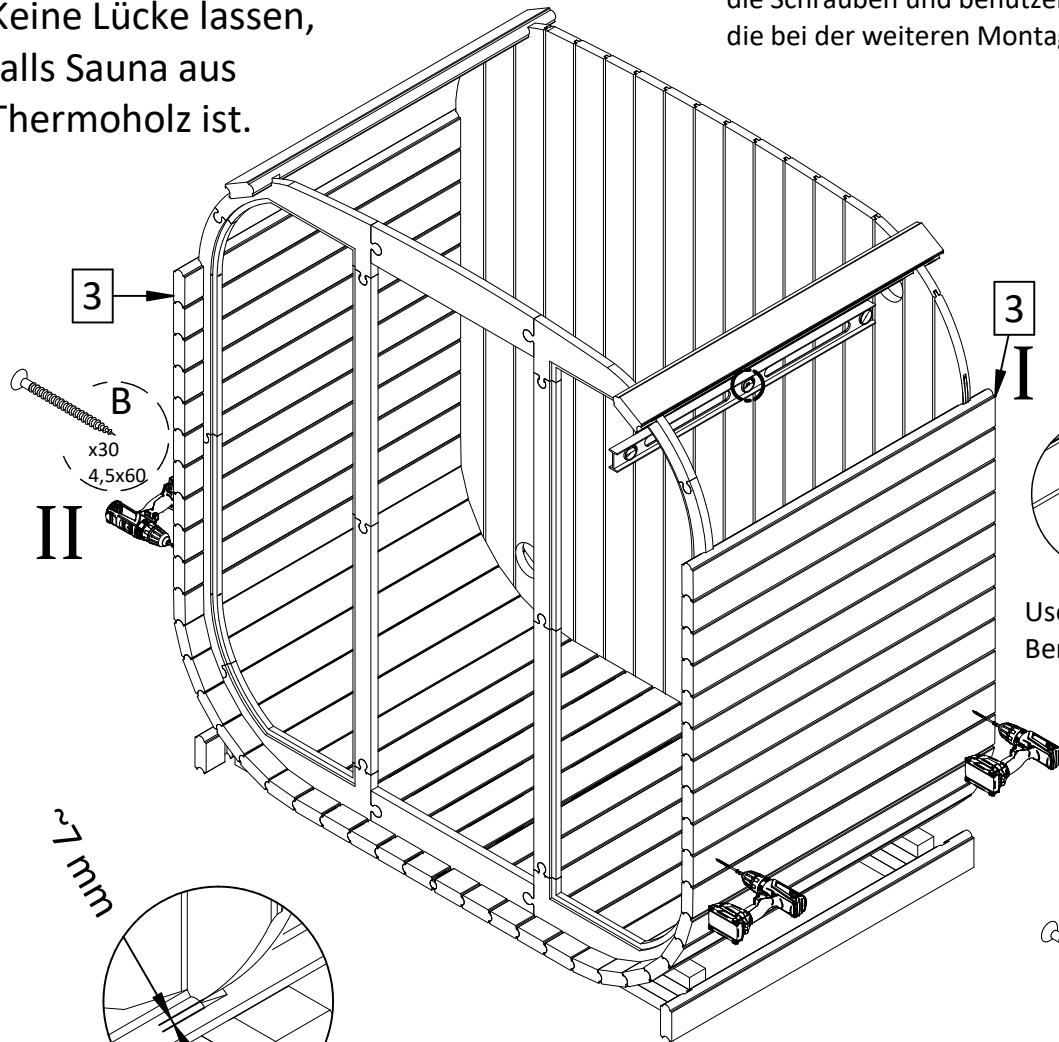

Use a spirit level  
Benutzen Sie eine Wasserwaage

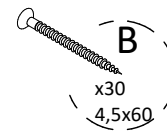
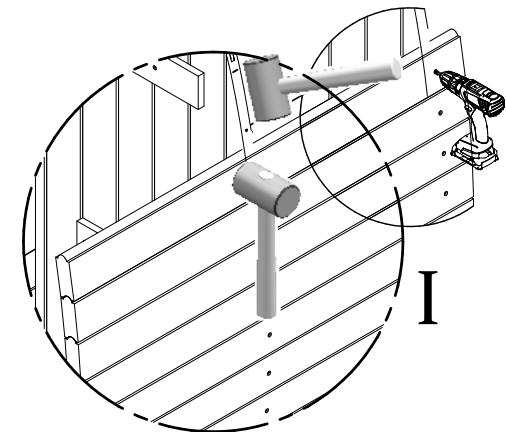
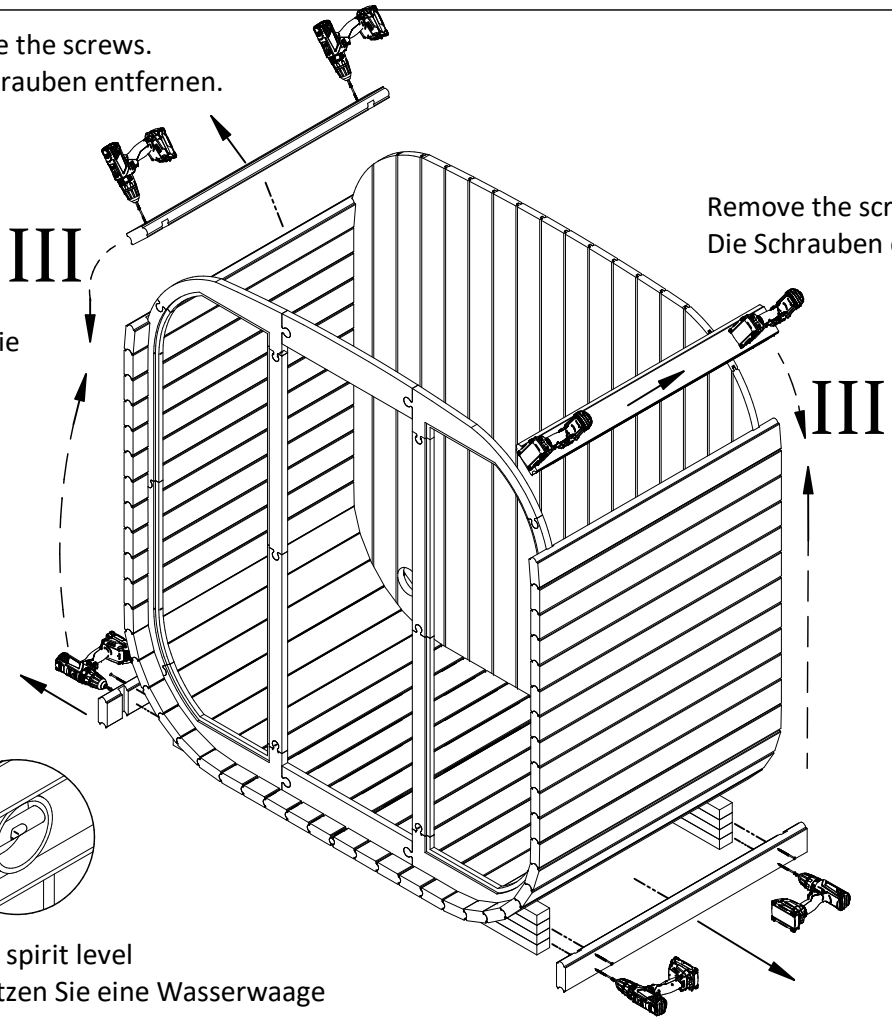

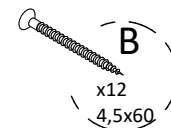
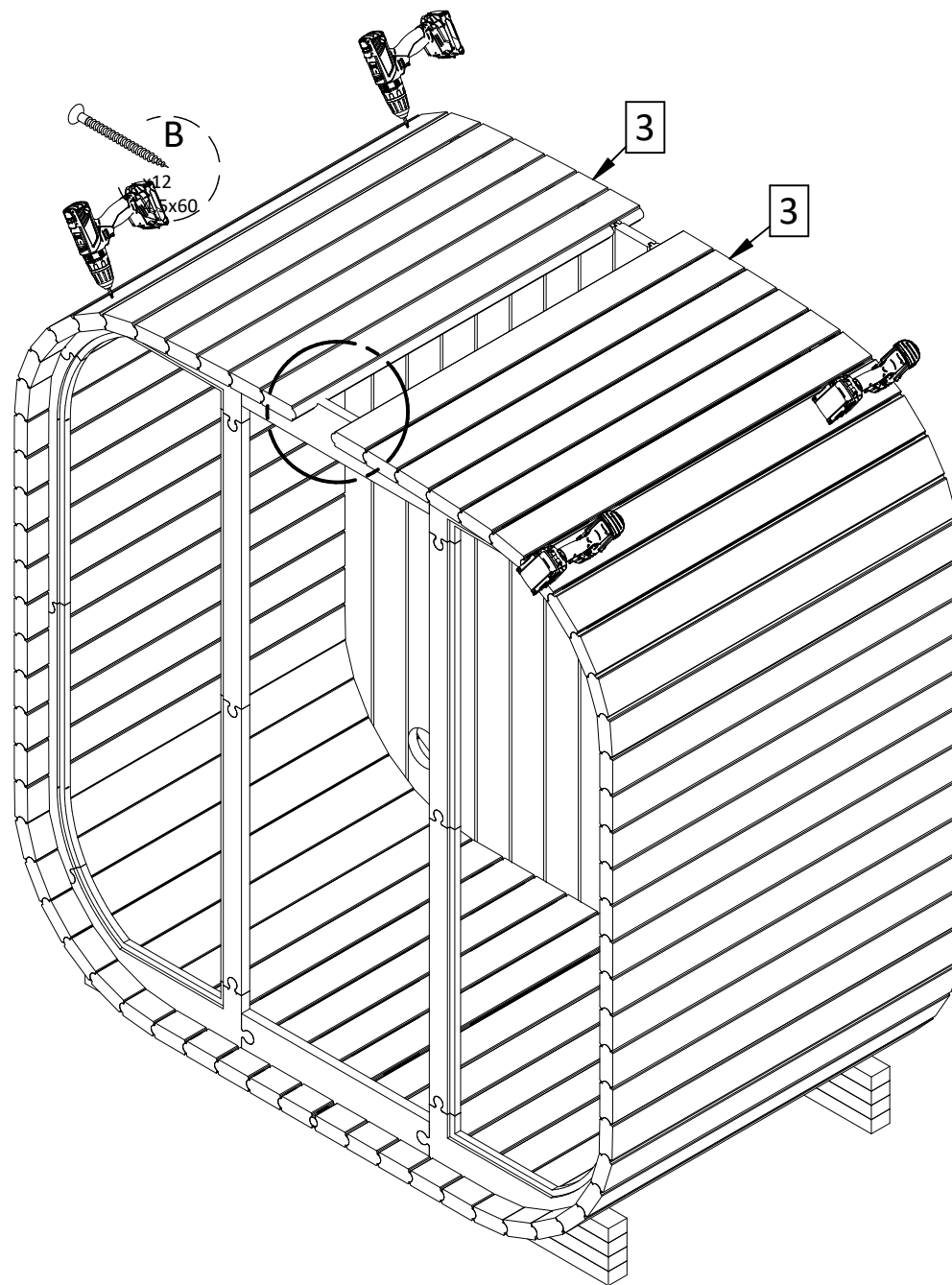
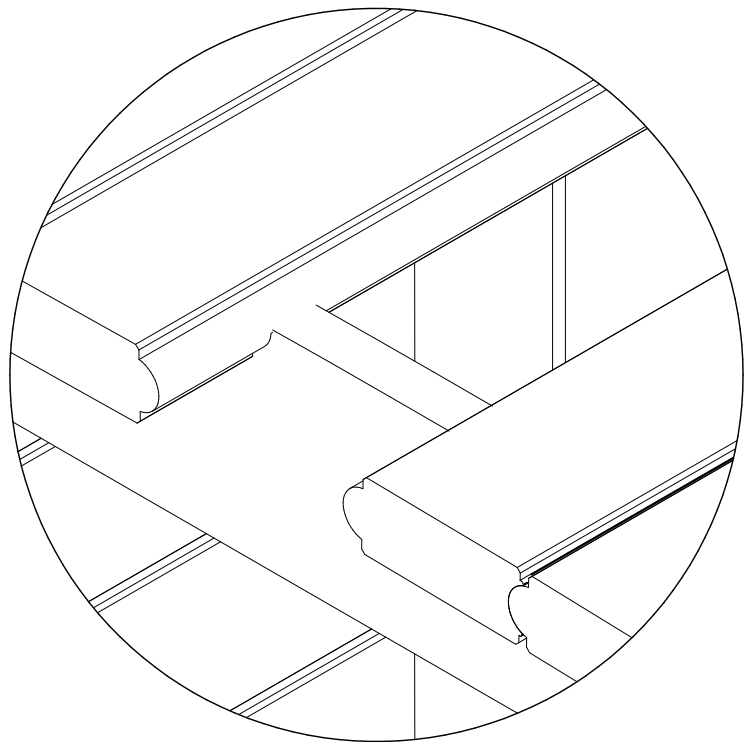

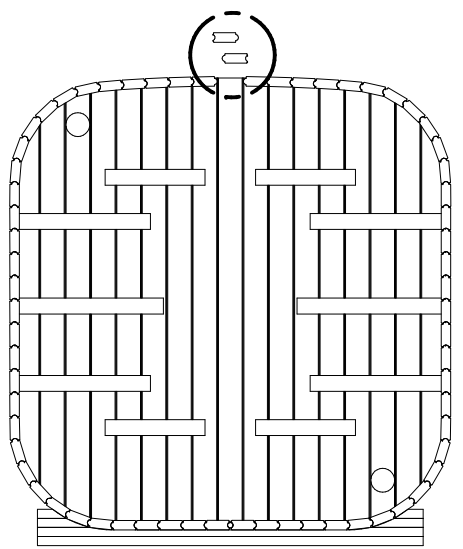
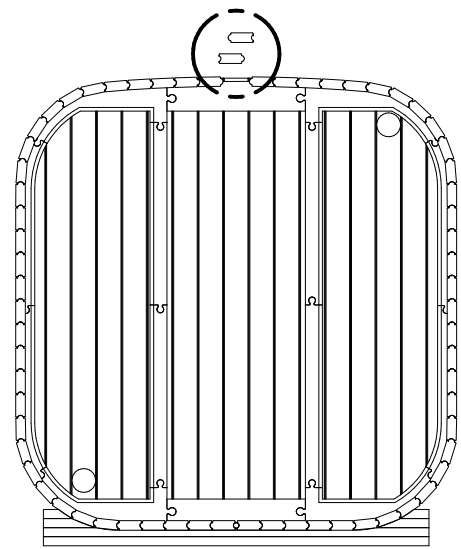
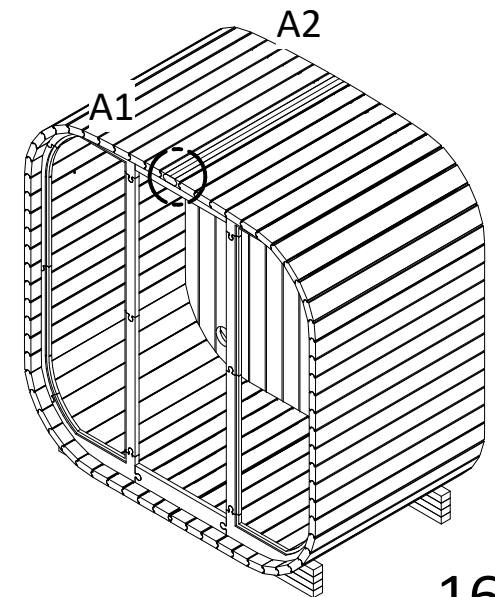
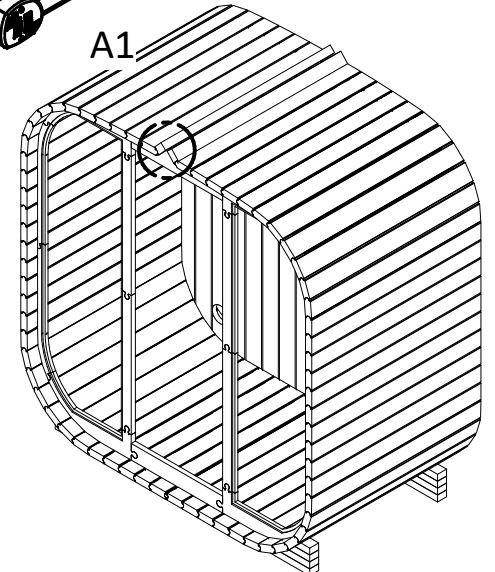
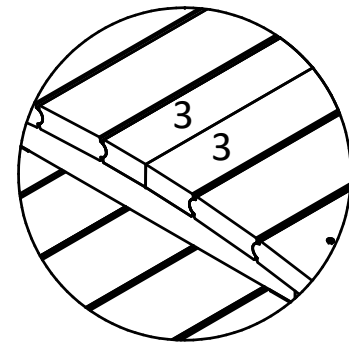
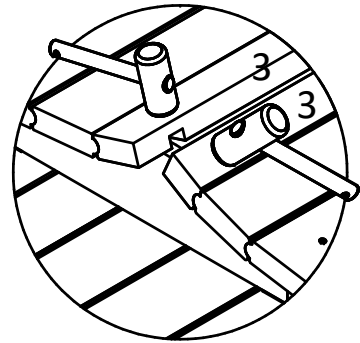
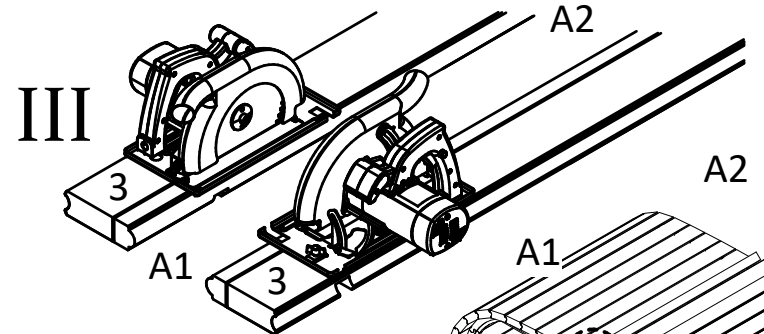
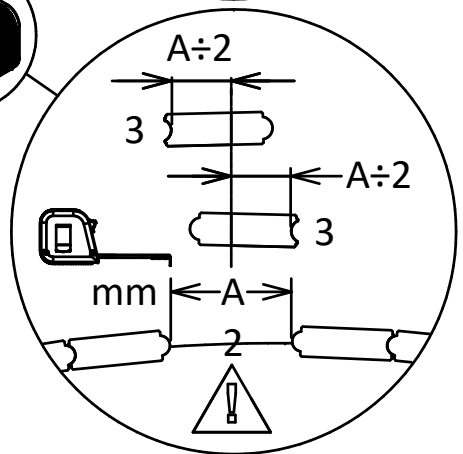
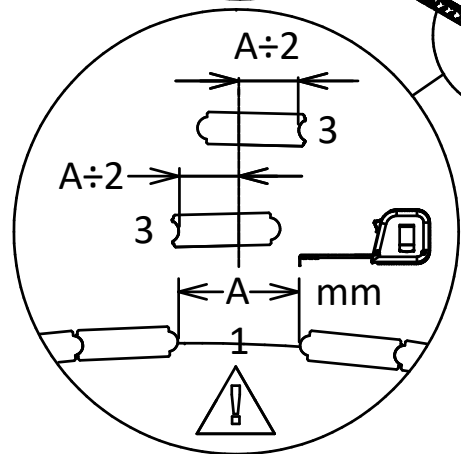
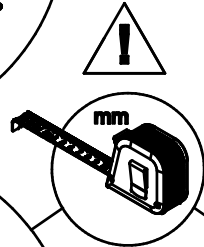
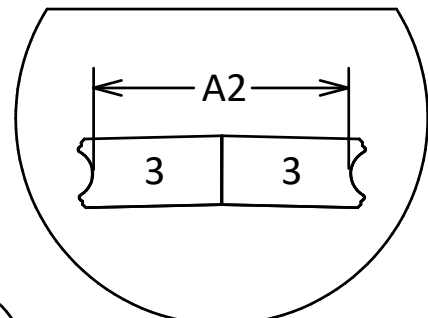
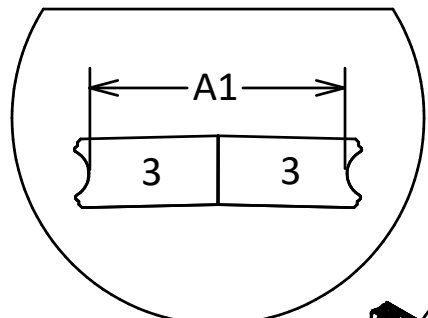



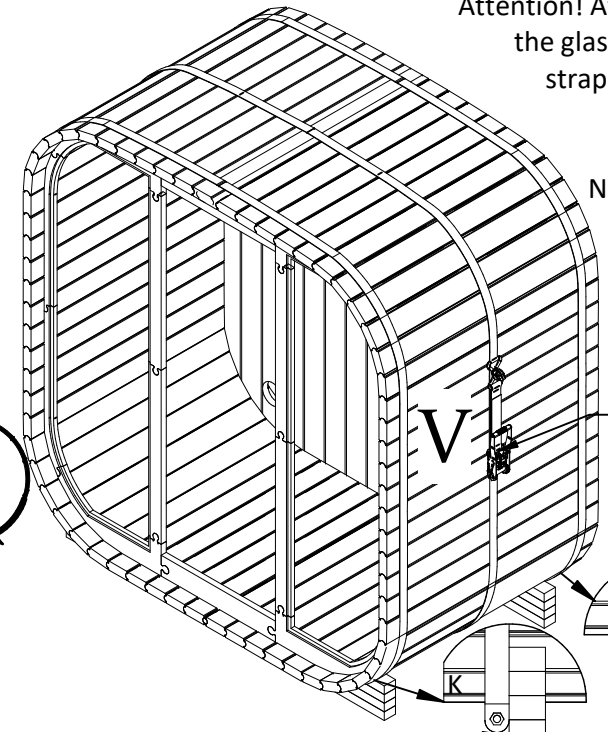
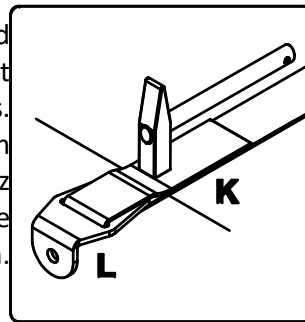
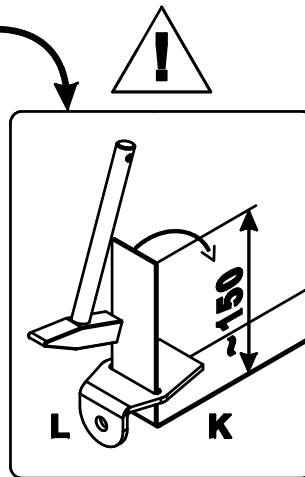
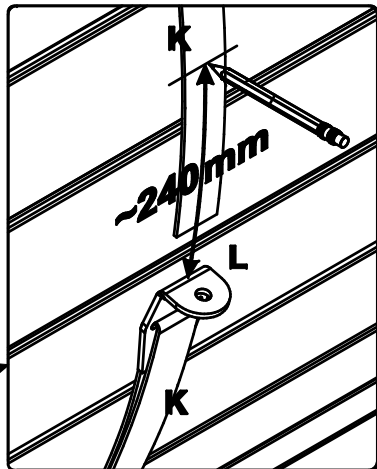
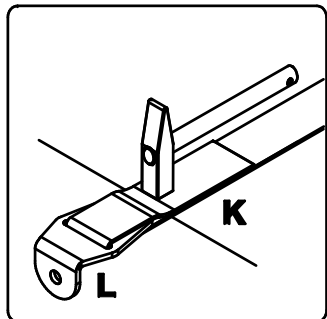
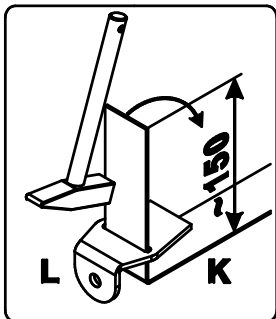

Attention! After installing the glass, tighten the straps completely.

Achtung! Nach Montage der Glas die Spanngurte vollständig spannen.

Remove. Entfernen.

III

Die Schrauben entfernen. Remove the screws.

Important! If you have a thermo wood sauna barrel, please do not remove the screws.



Wichtig! Wenn Sie ein Saunafäß aus Thermoholz haben, entfernen Sie bitte nicht die Schrauben.

II

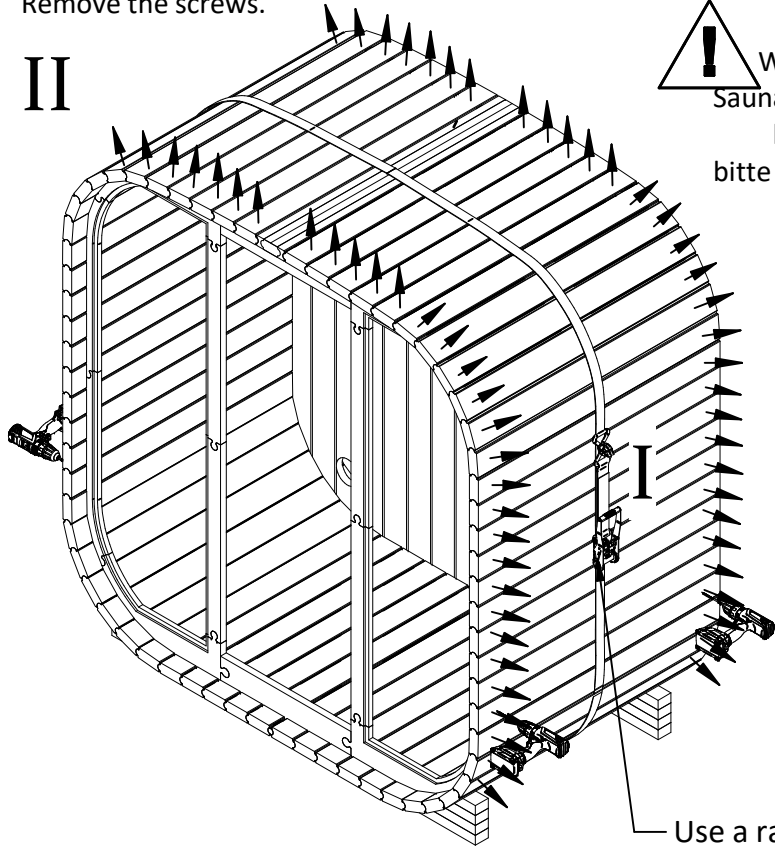

Use a ratchet strap. Benutzen sie ein Spannband.

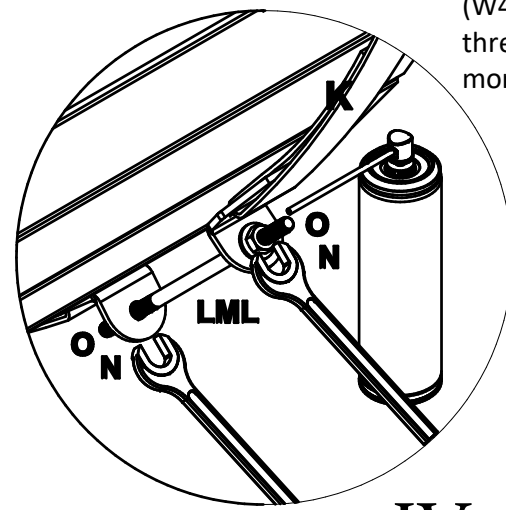

Attention! When assembling and maintaining/retightening the threaded rods, the threaded rods must be oiled with oil (W44 or Würth HPS1400). In this way, damage to the threaded rod can be avoided and it can be clamped more easily.

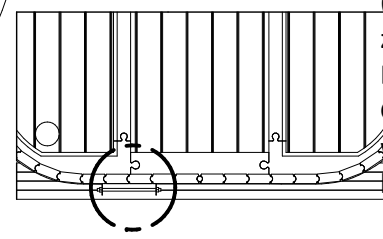
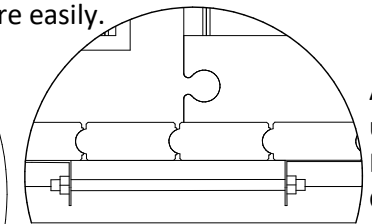

Achtung! Bei der Montage und bei der Pflege/Nachspannen der Gewindestangen, ist die Gewindestange mit Öl (W44 oder Würth HPS1400) zu ölen. So kann eine Beschädigung an der Gewindestange vermieden werden und man kann es leichter spannen.

IV

Before processing the screws.

Pre-drill the holes  
with a 4 mm drill bit.

Bitte bohren Sie  
die  $\phi 4$ mm Löcher vor  
dem Schrauben vor

Use a spirit level  
Benutzen Sie eine  
Wasserwaage

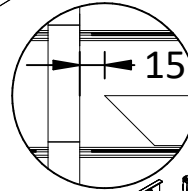
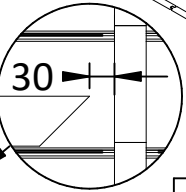
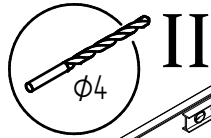

I

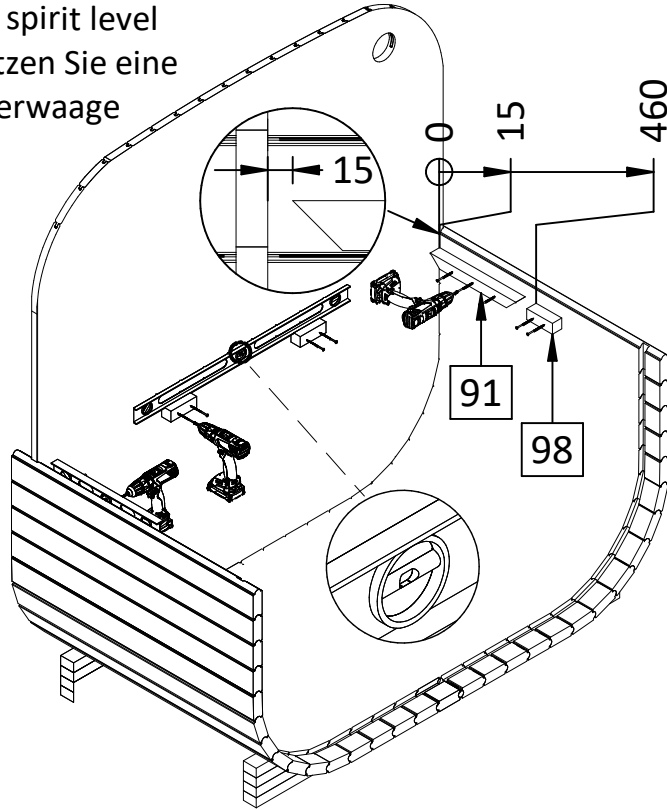
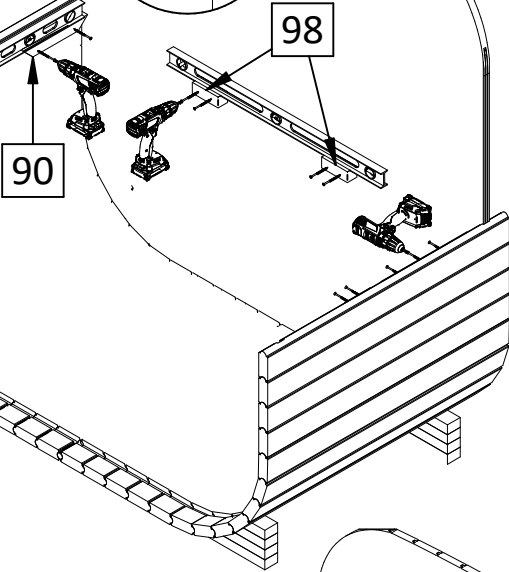
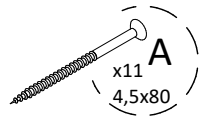
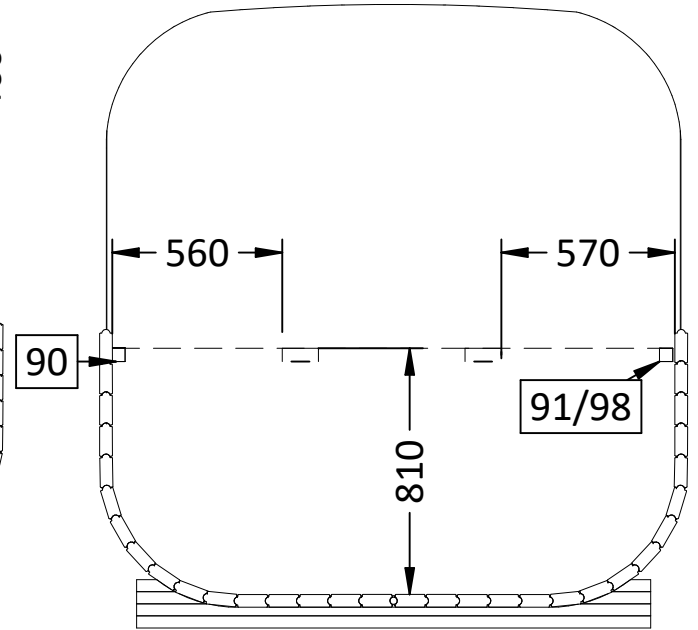

III

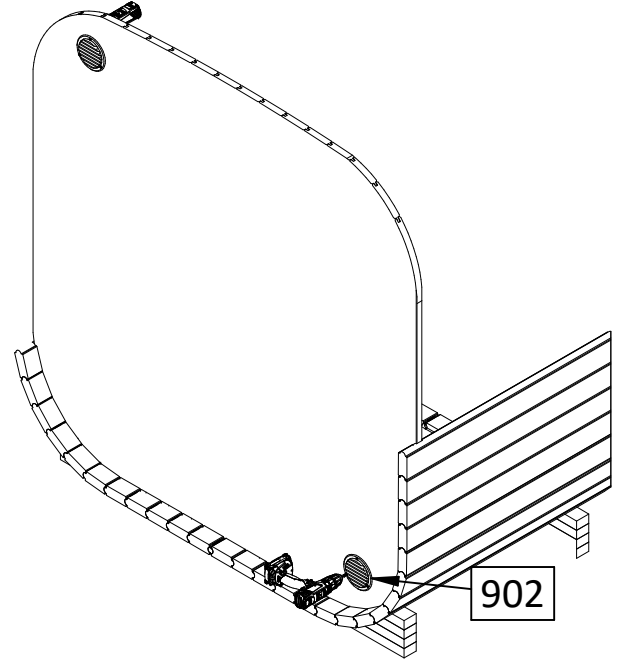
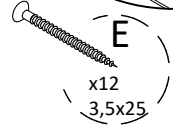
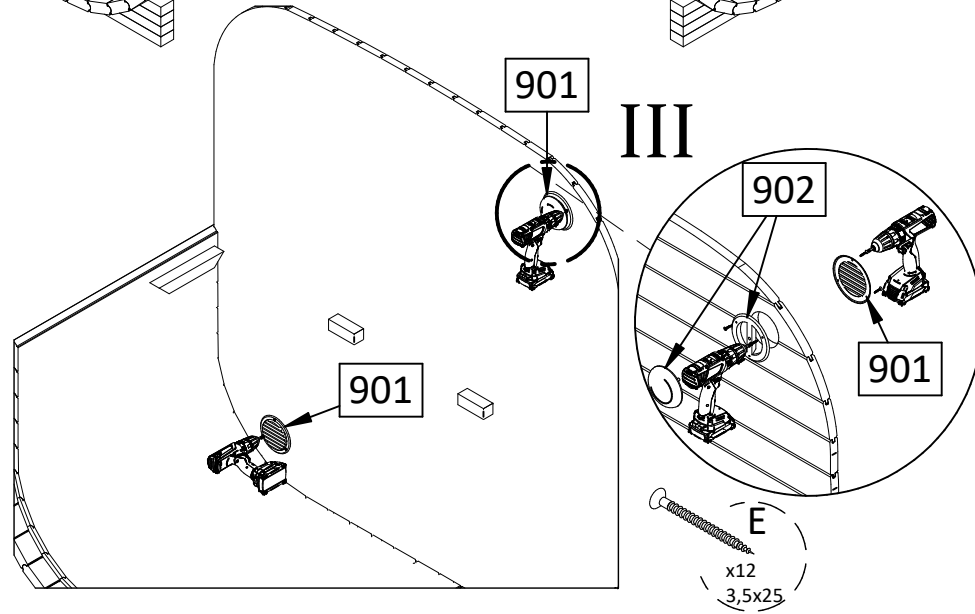

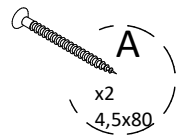
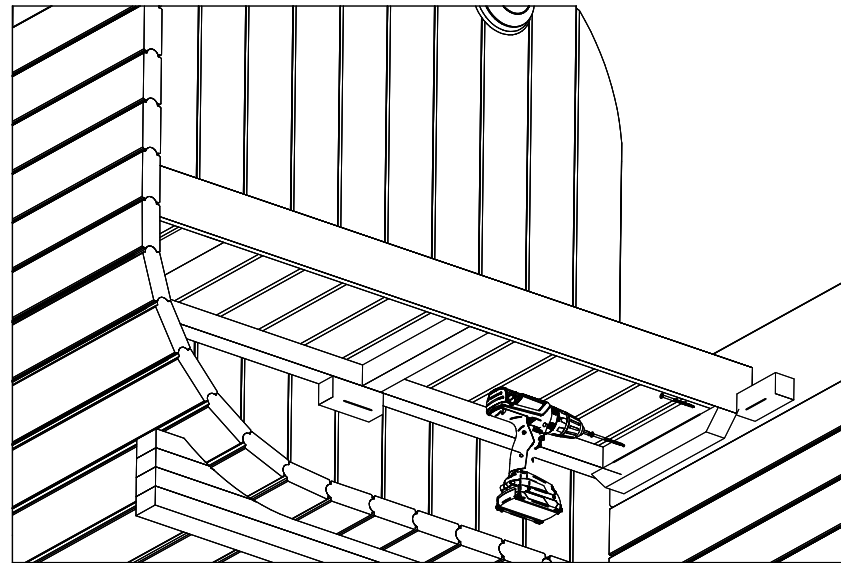
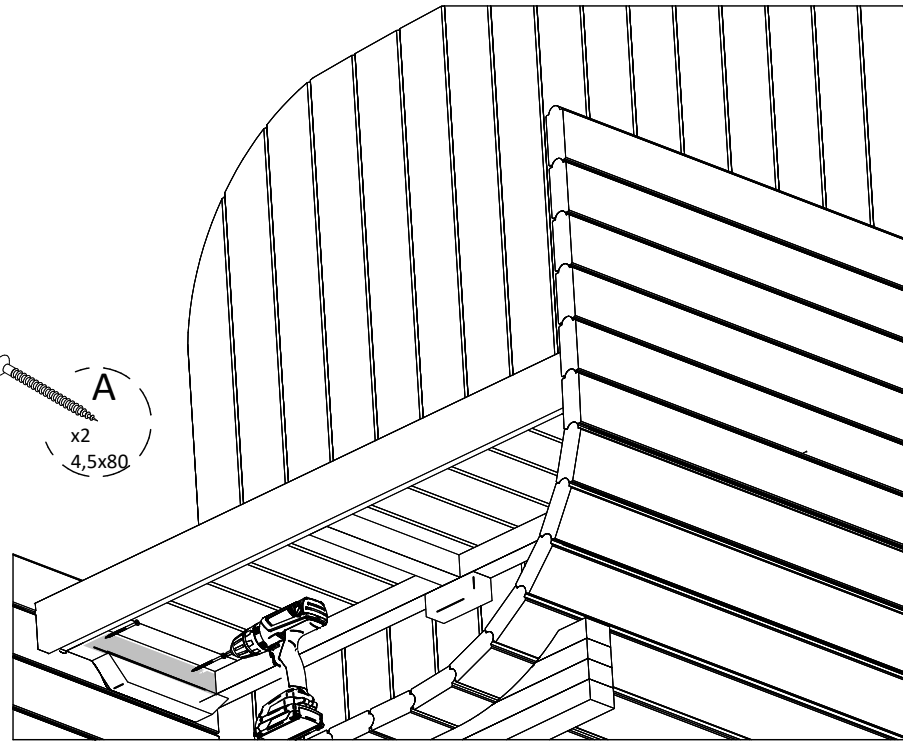
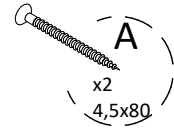
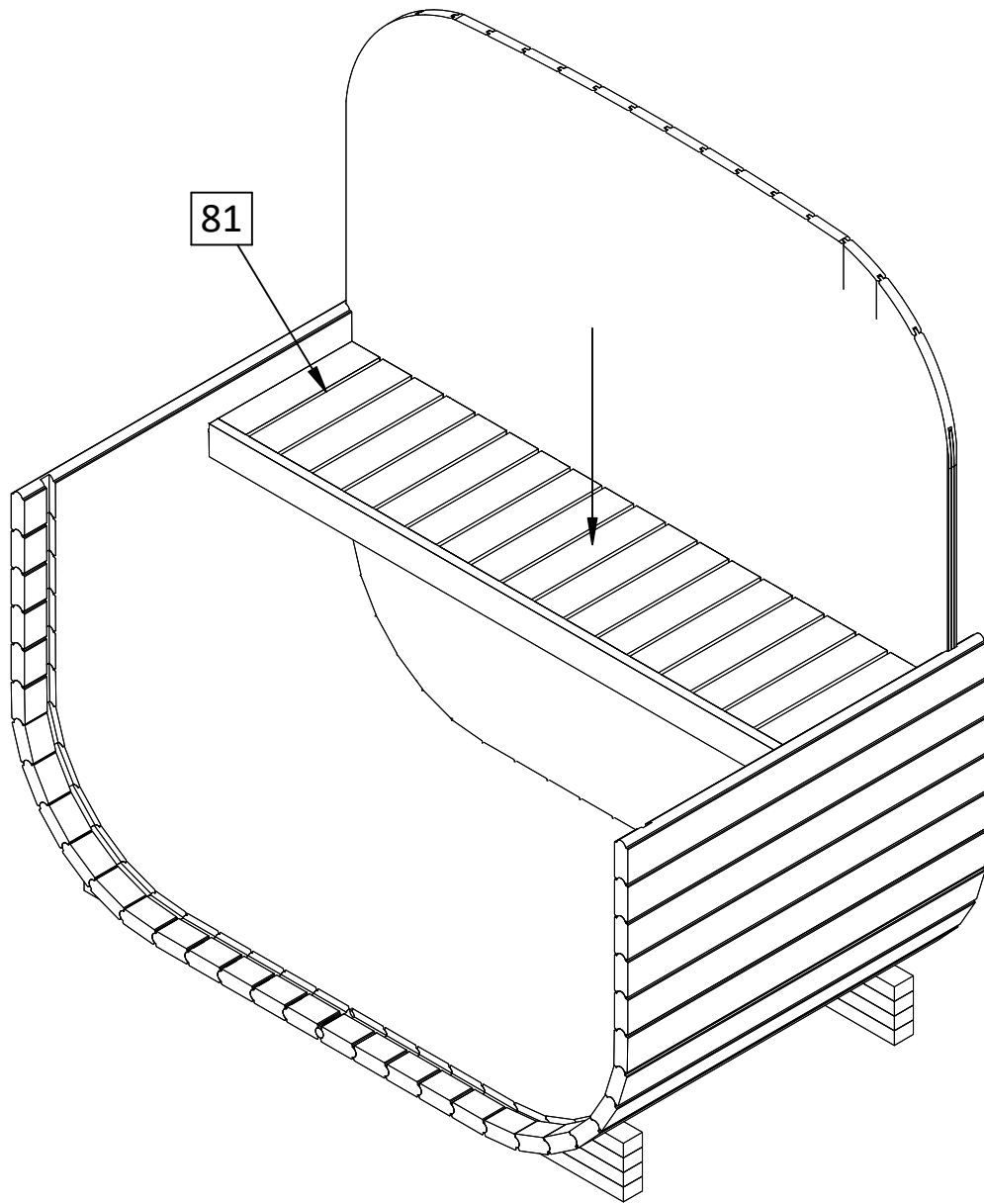

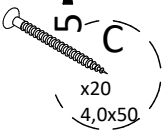
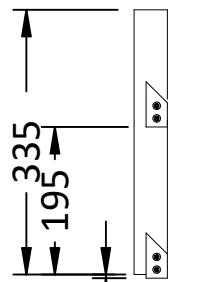

Before processing the screws.  
Pre-drill the holes  
with a 4 mm drill bit.

Bitte bohren Sie  
die  $\phi 4$ mm Löcher vor  
dem Schrauben vor

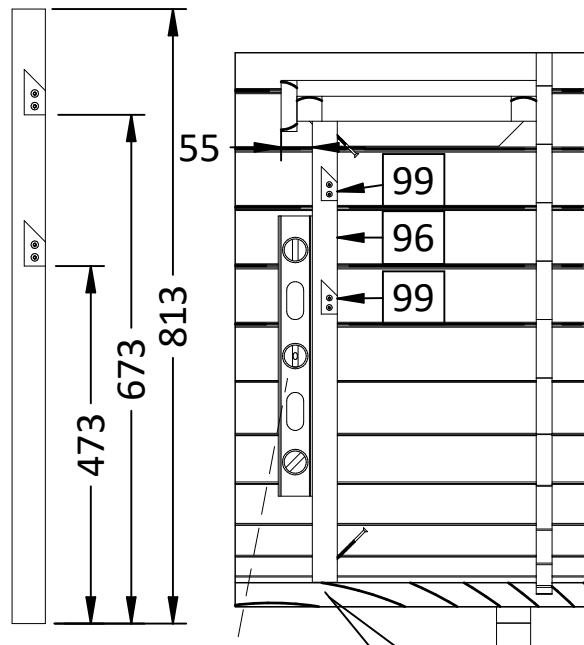
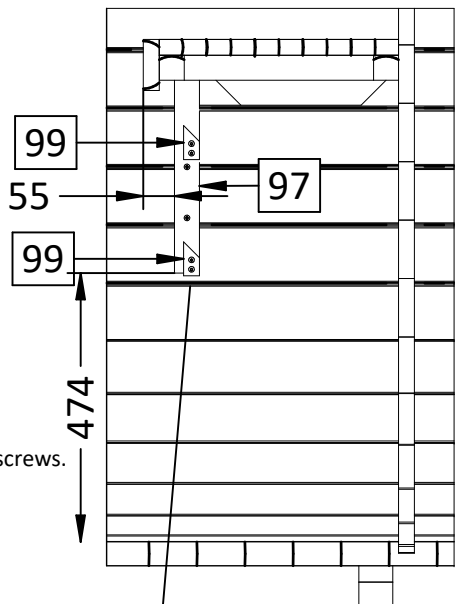

2x

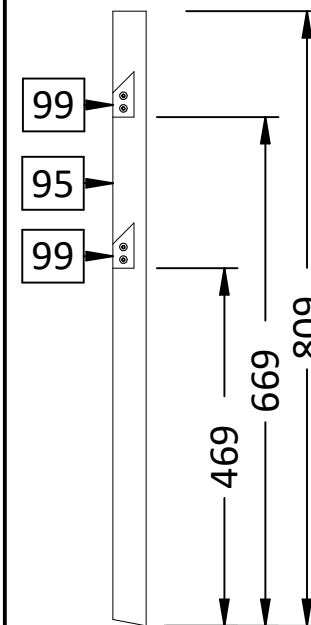

2x

Next page

Nächste Seite

Before processing the screws.  
Pre-drill the holes  
with a 4 mm drill bit.

Bitte bohren Sie  
die  $\phi 4$ mm Löcher vor  
dem Schrauben vor

Use a spirit level  
Benutzen Sie eine  
Wasserwaage

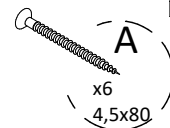
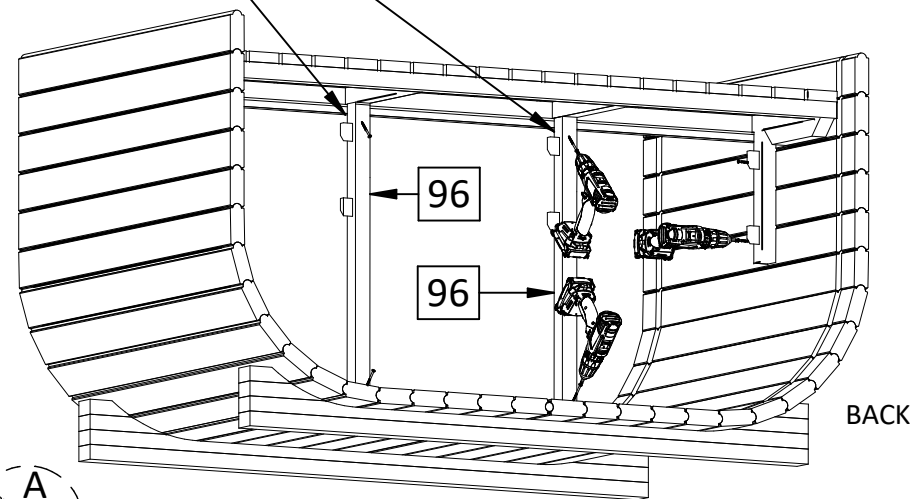
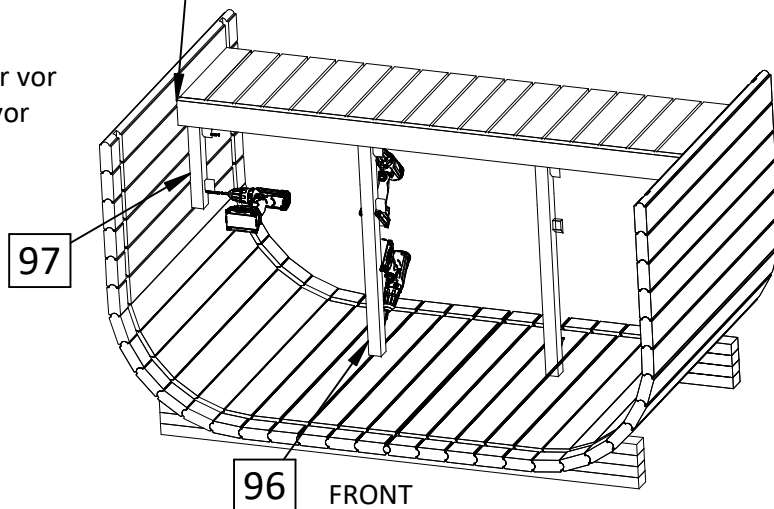
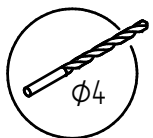

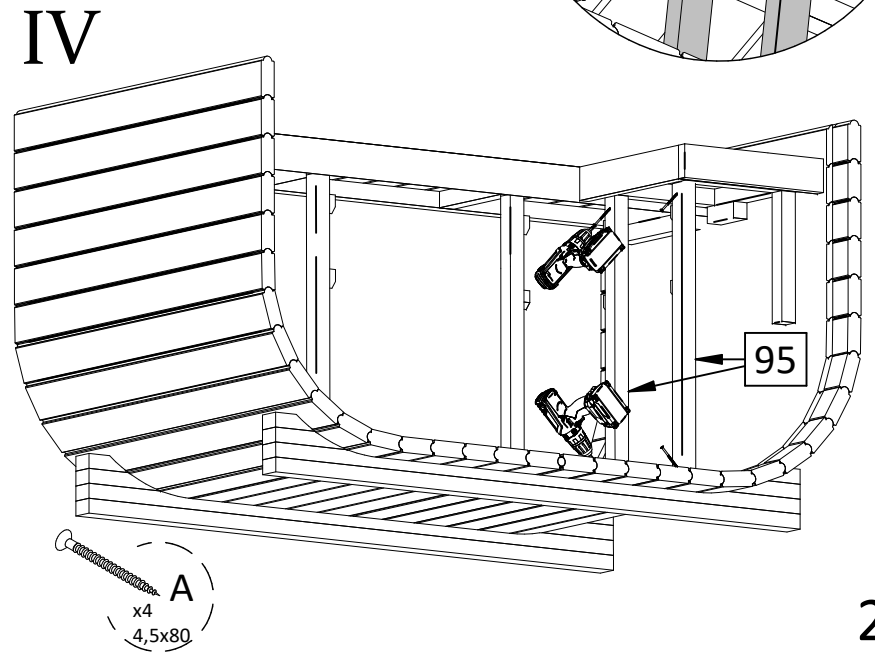
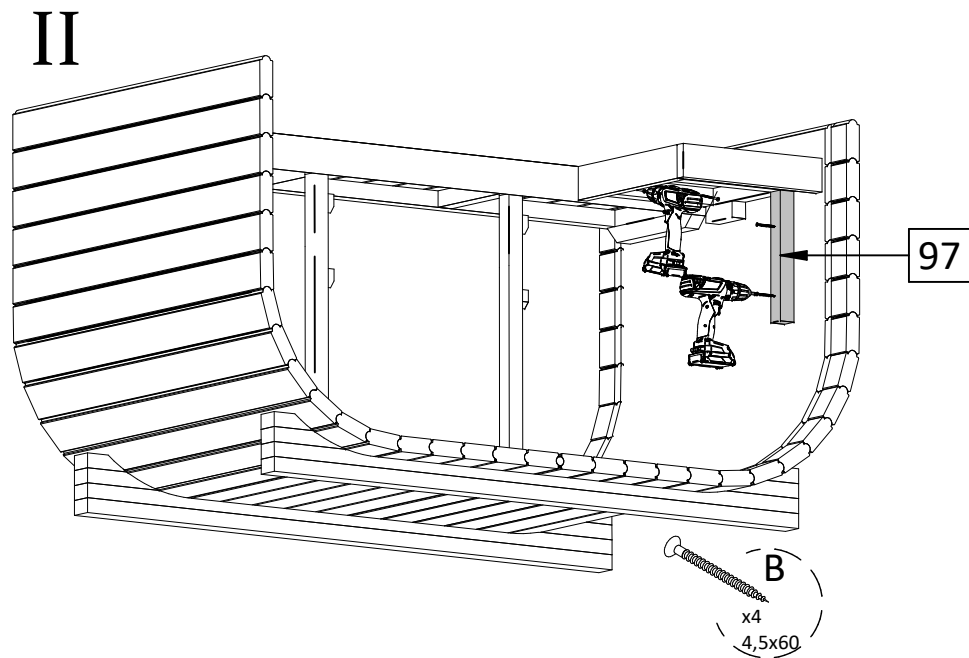
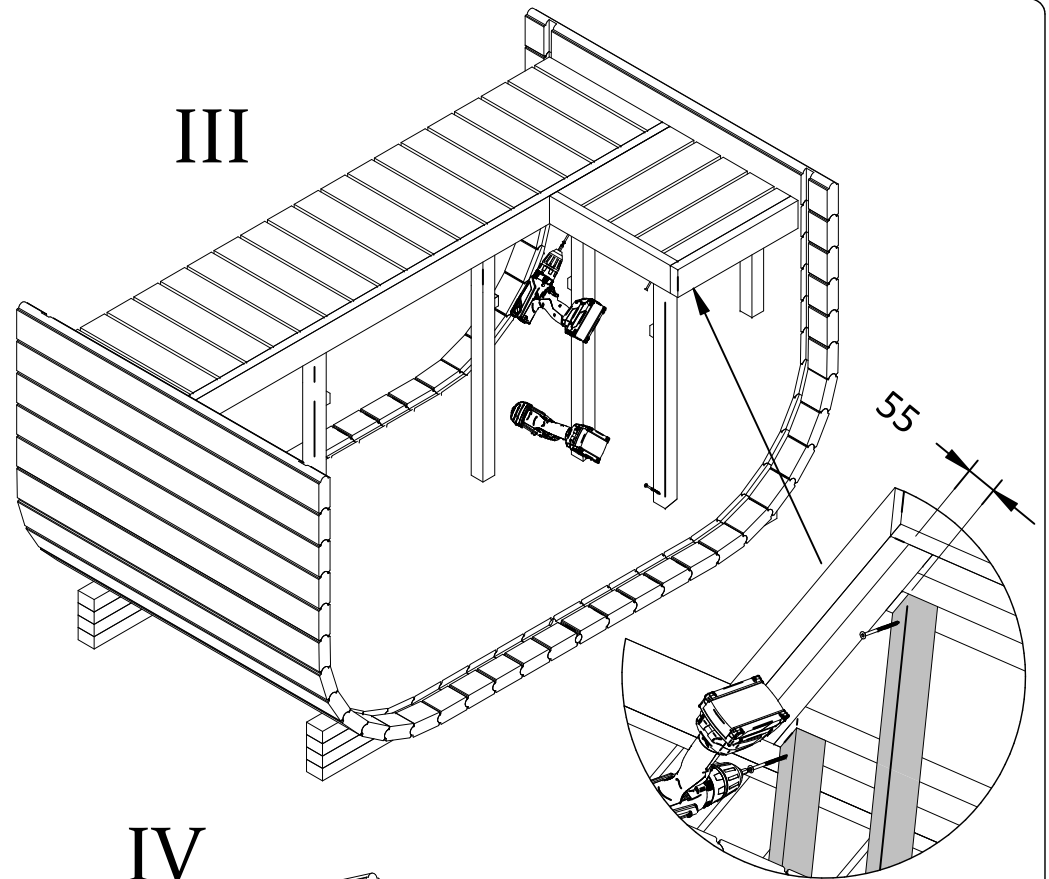
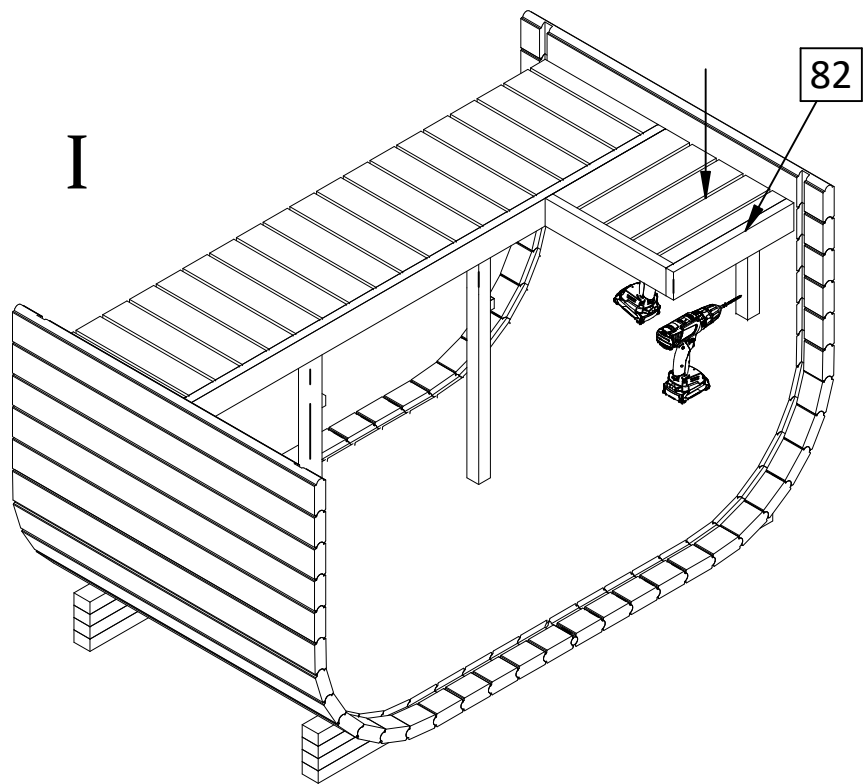

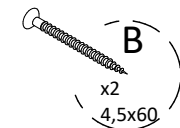
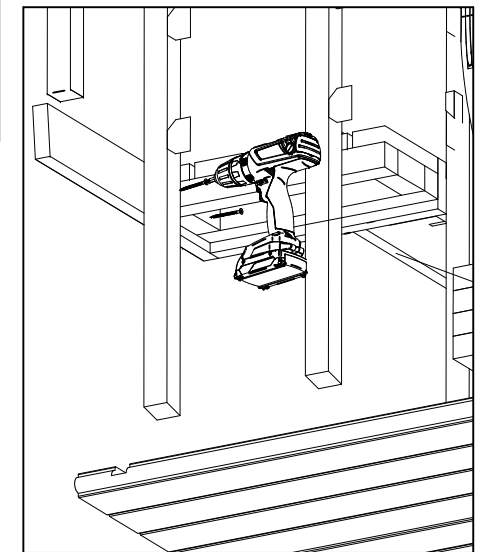
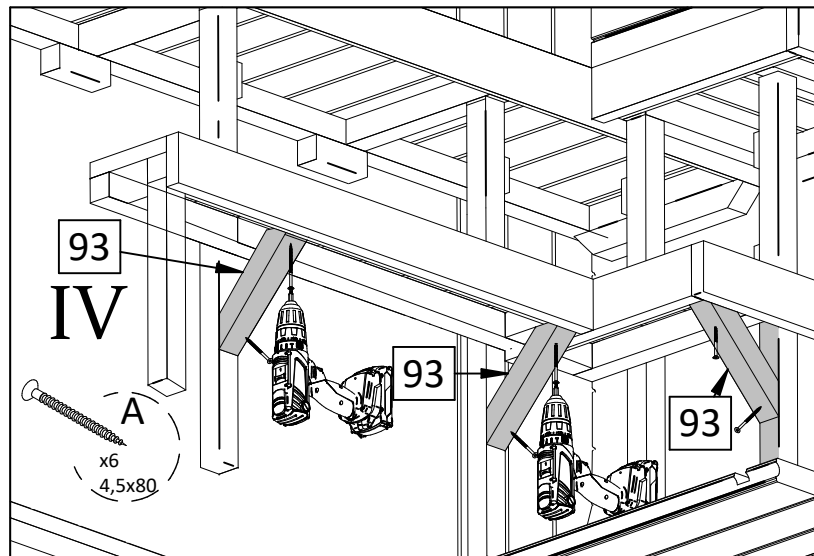
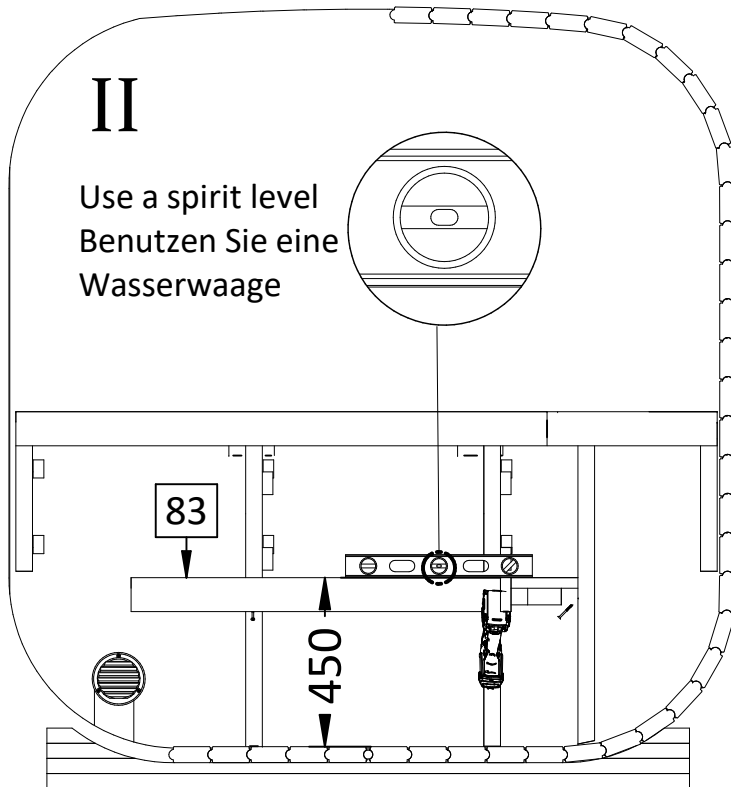
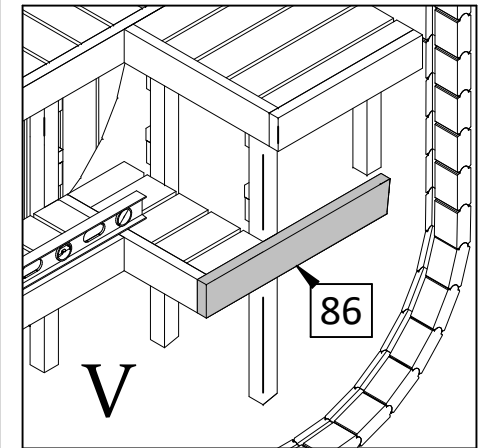
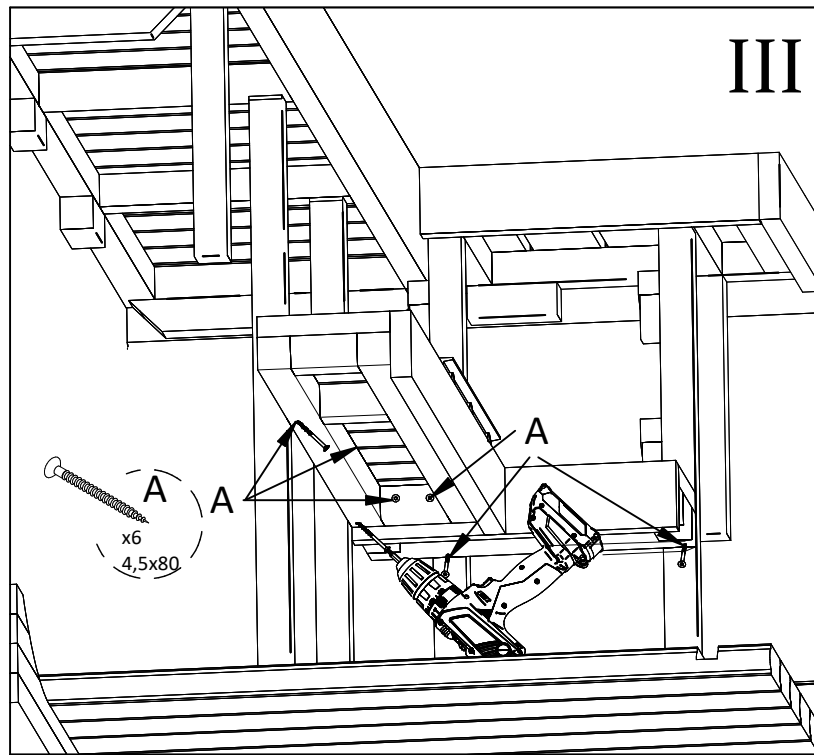
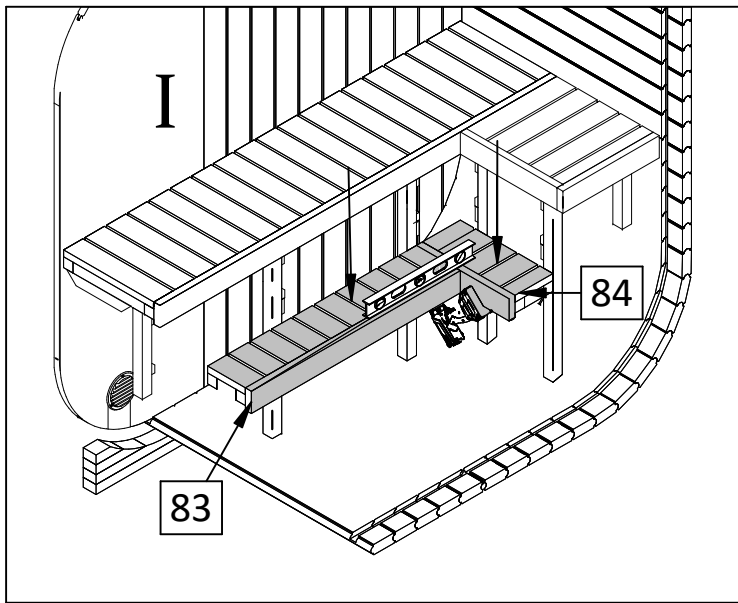

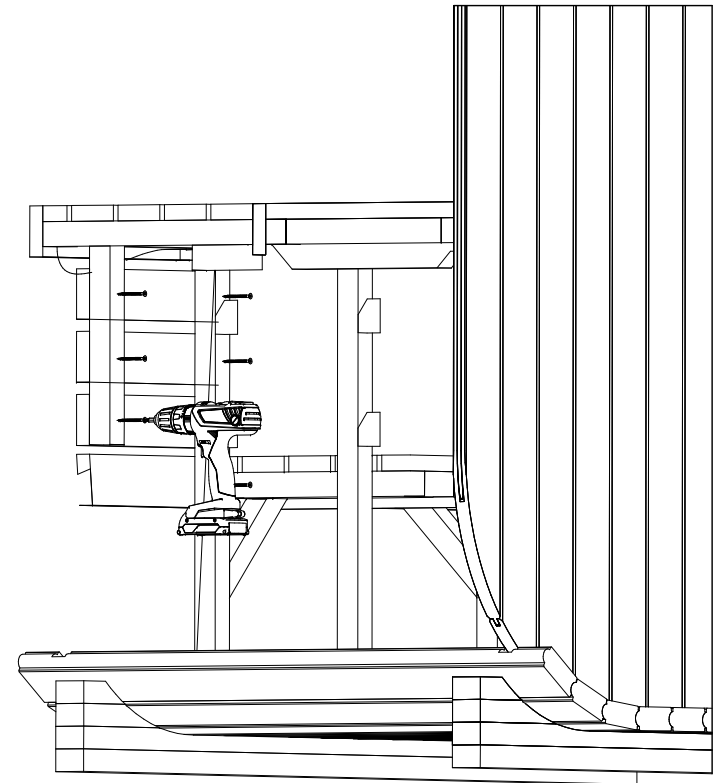
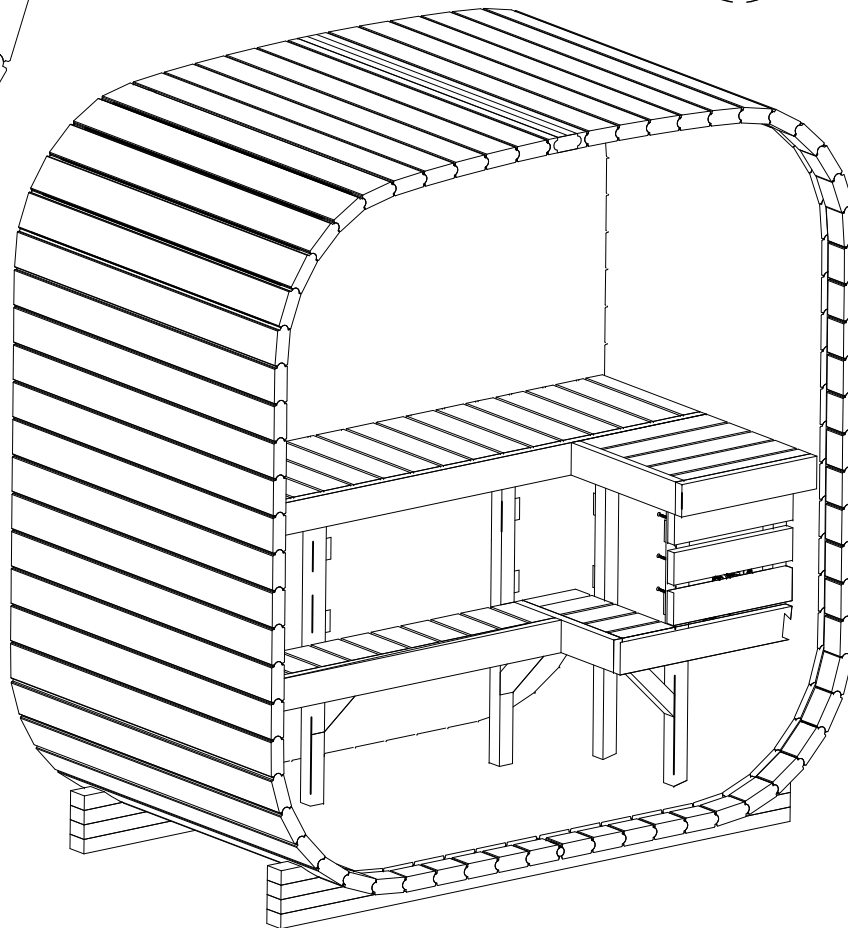
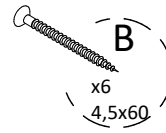
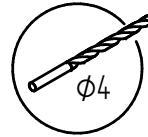
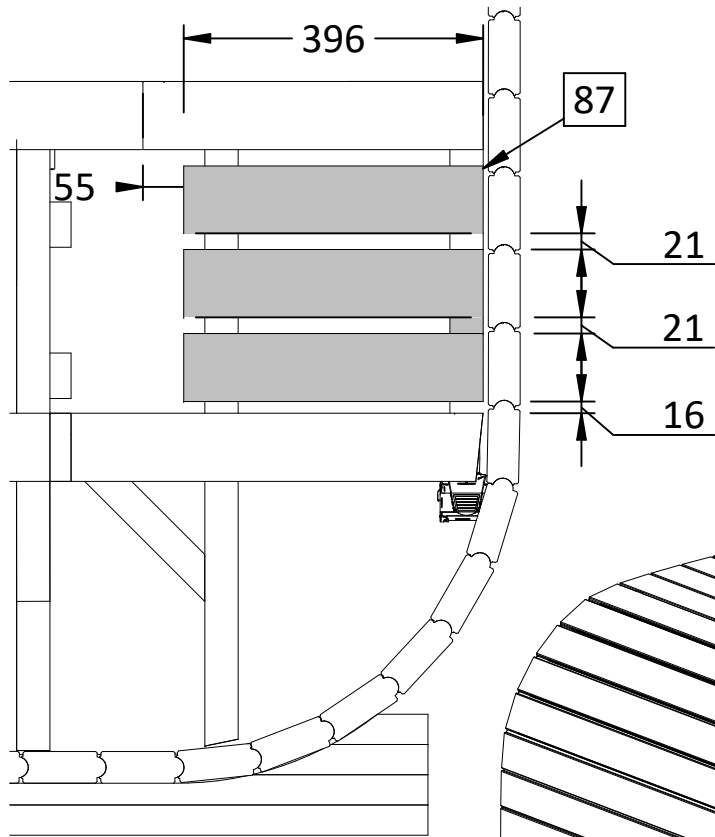

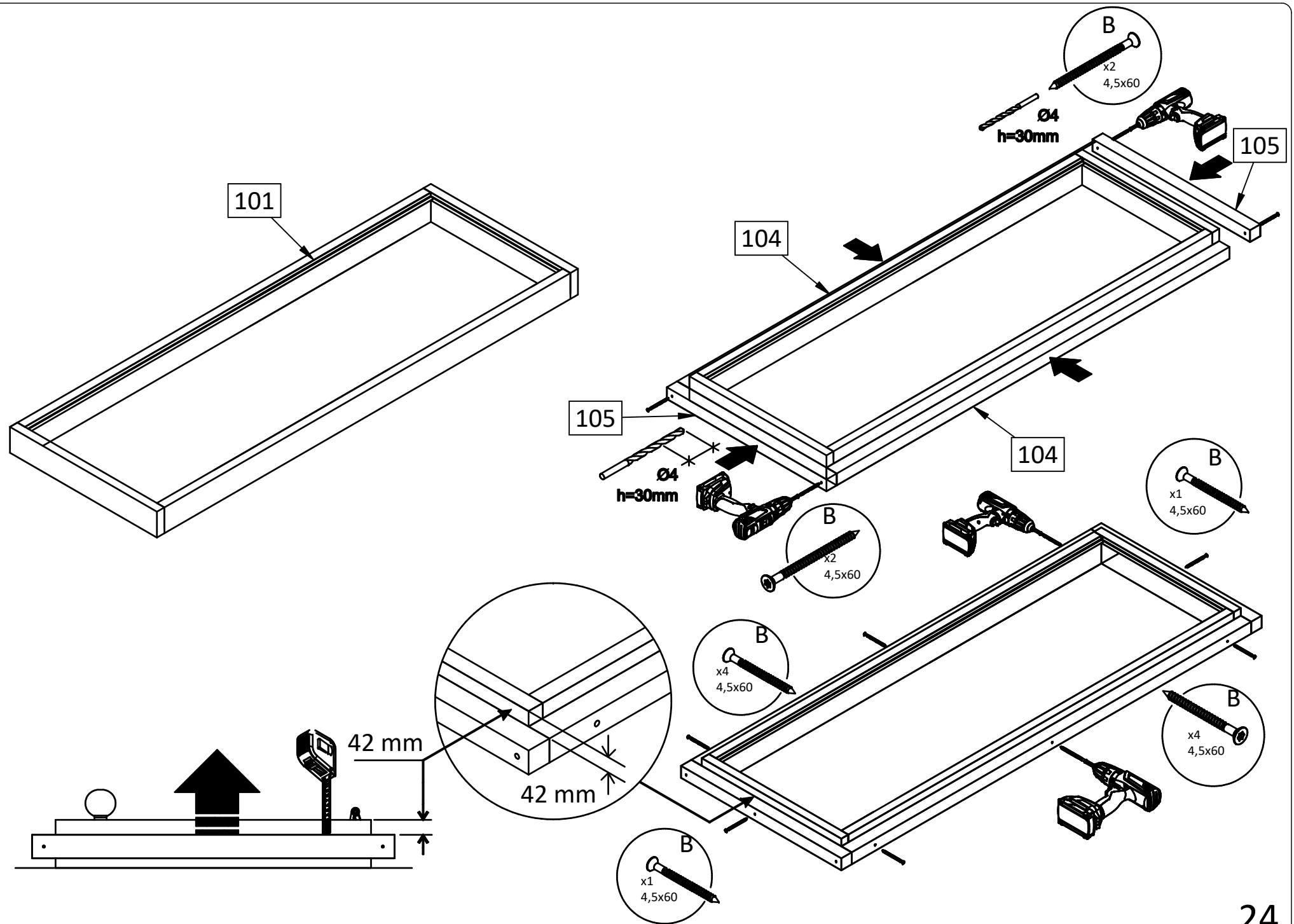



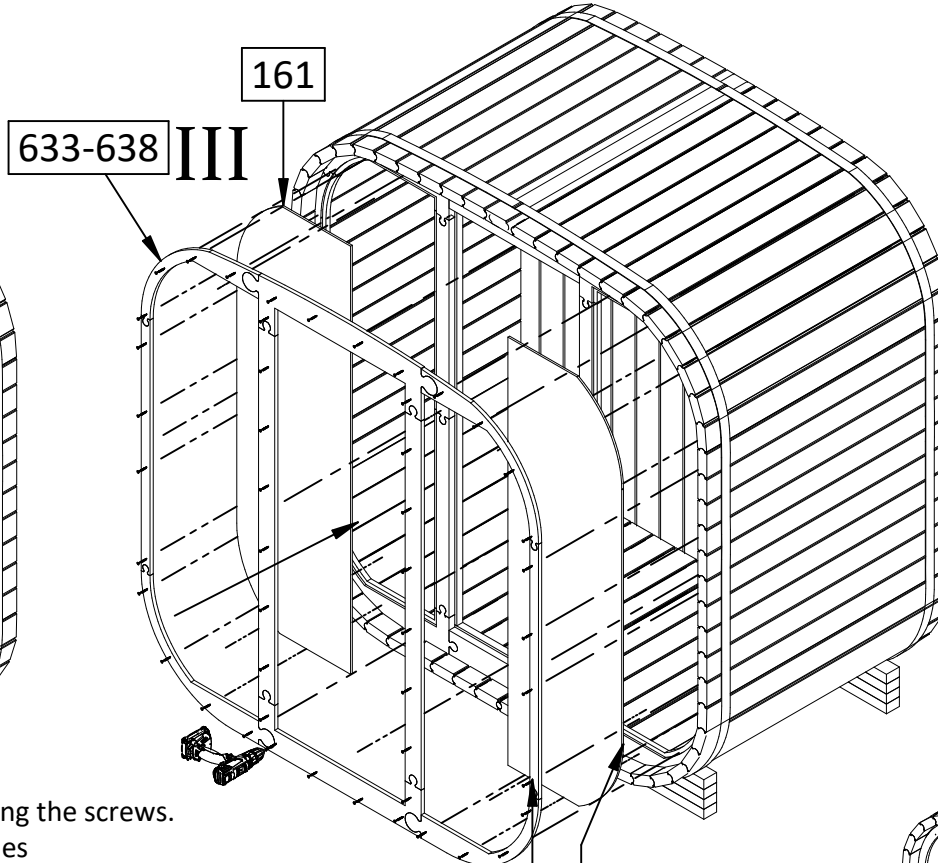
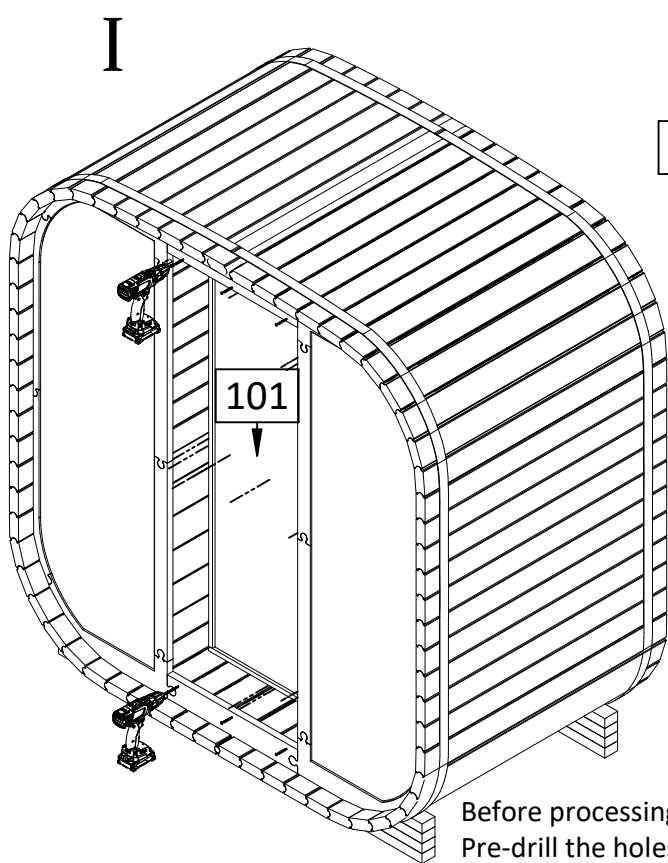

Attention! After installing the glass, tighten the straps completely.

Achtung! Nach Montage der Glas die Spanngurte vollständig spannen.

Before processing the screws. Pre-drill the holes with a  $\phi 3$ mm drill bit.

Bitte bohren Sie die  $\phi 3$ mm Löcher vor dem Schrauben vor

Before processing the screws. Pre-drill the holes with a  $\phi 3$ mm drill bit.

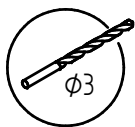
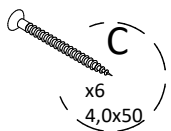

Bitte bohren Sie die  $\phi 3$ mm Löcher vor dem Schrauben vor

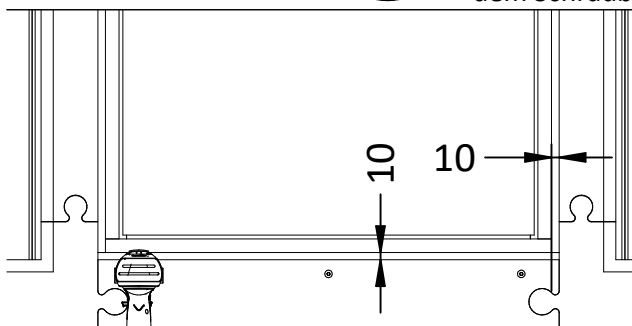

IV

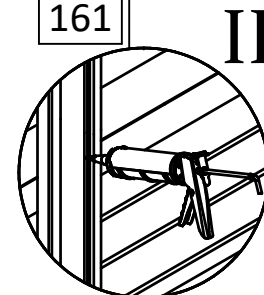
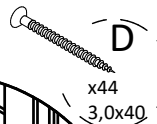
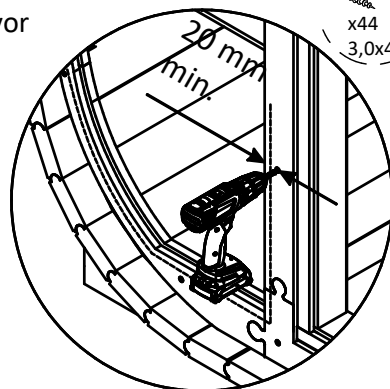

Use waterproof silicone

Verwenden Sie wasserfestes Silikon

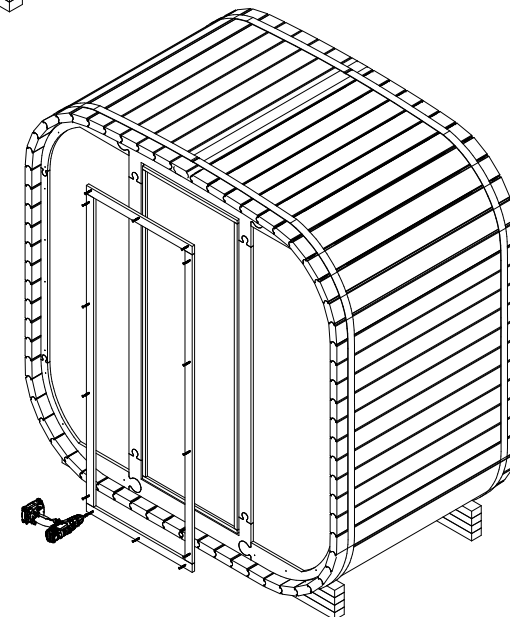
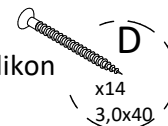

V

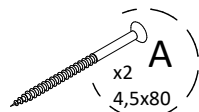
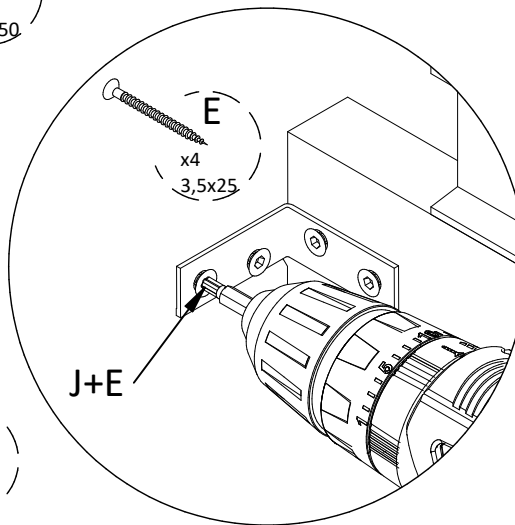
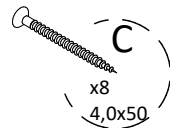
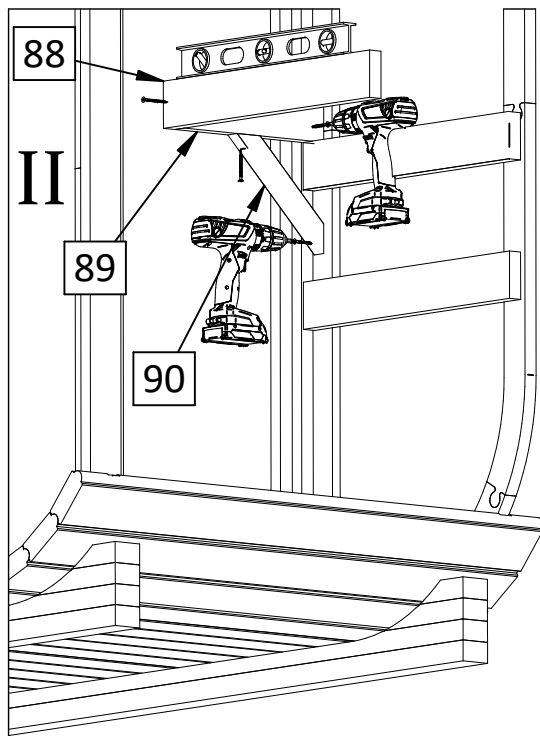
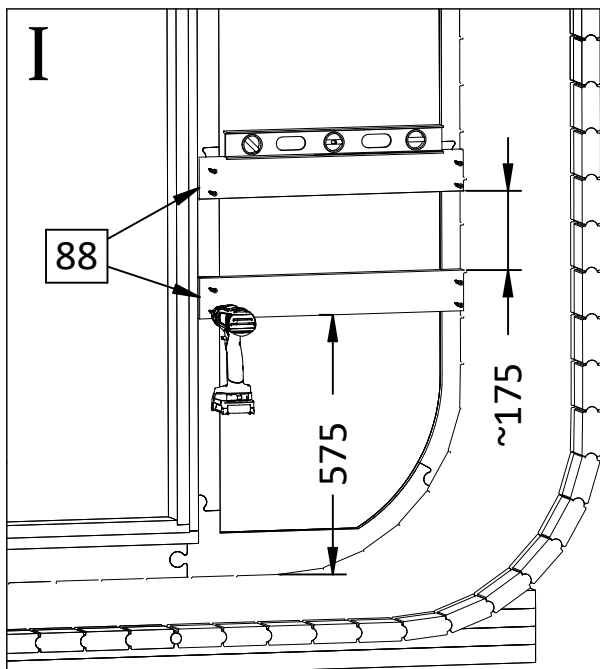

Use a spirit level  
Benutzen Sie eine  
Wasserwaage

Before processing the screws.  
Pre-drill the holes  
with a 4 mm drill bit.

Bitte bohren Sie  
die  $\phi 4$ mm Löcher vor  
dem Schrauben vor

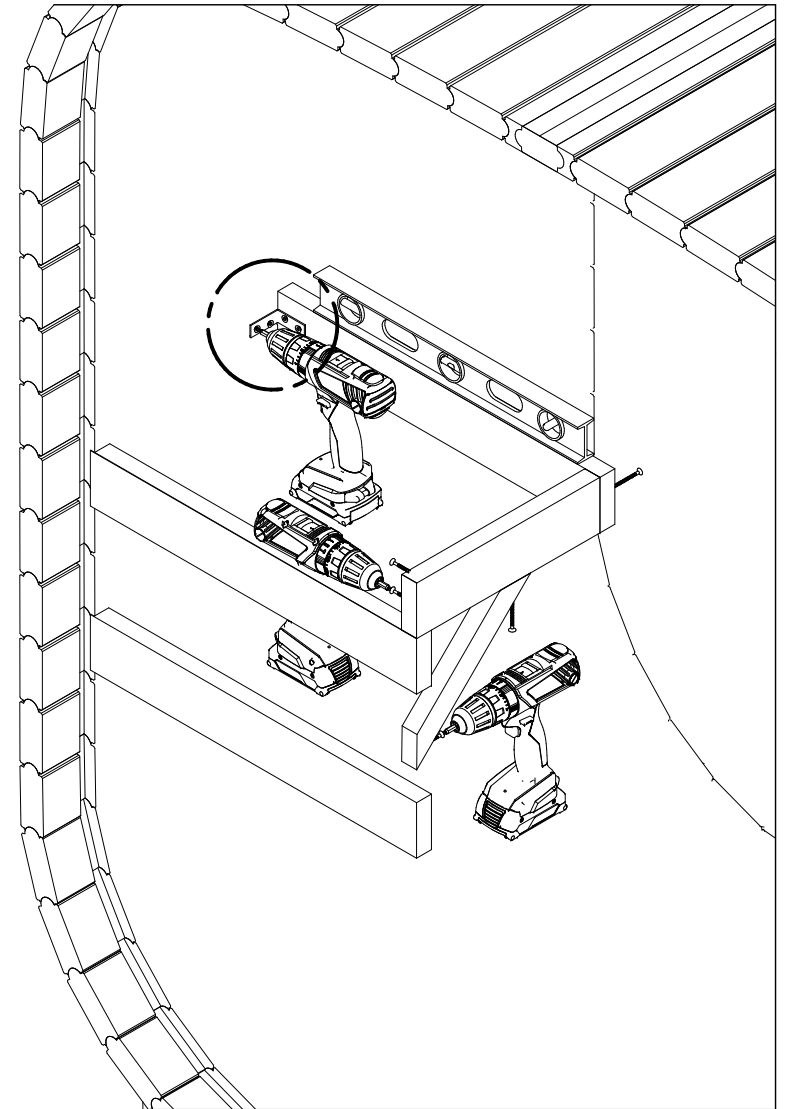
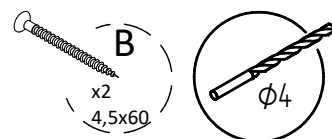

III

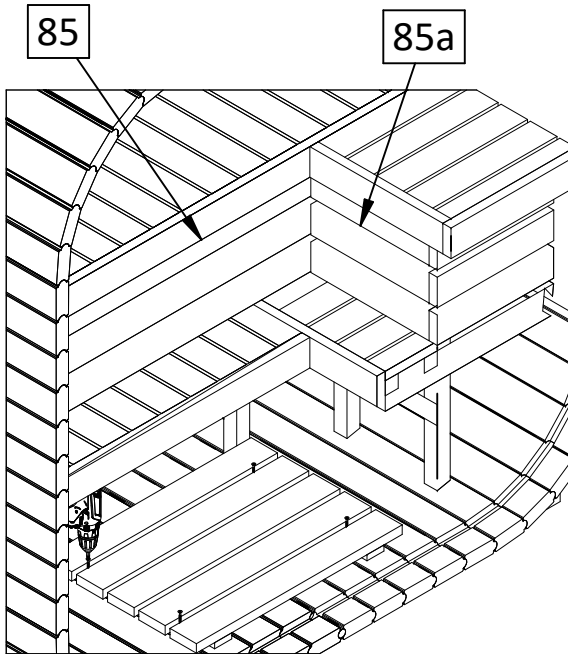
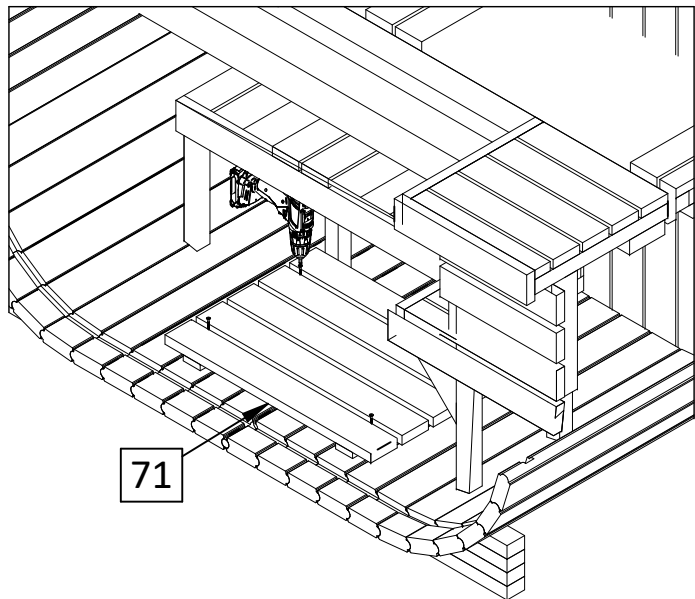
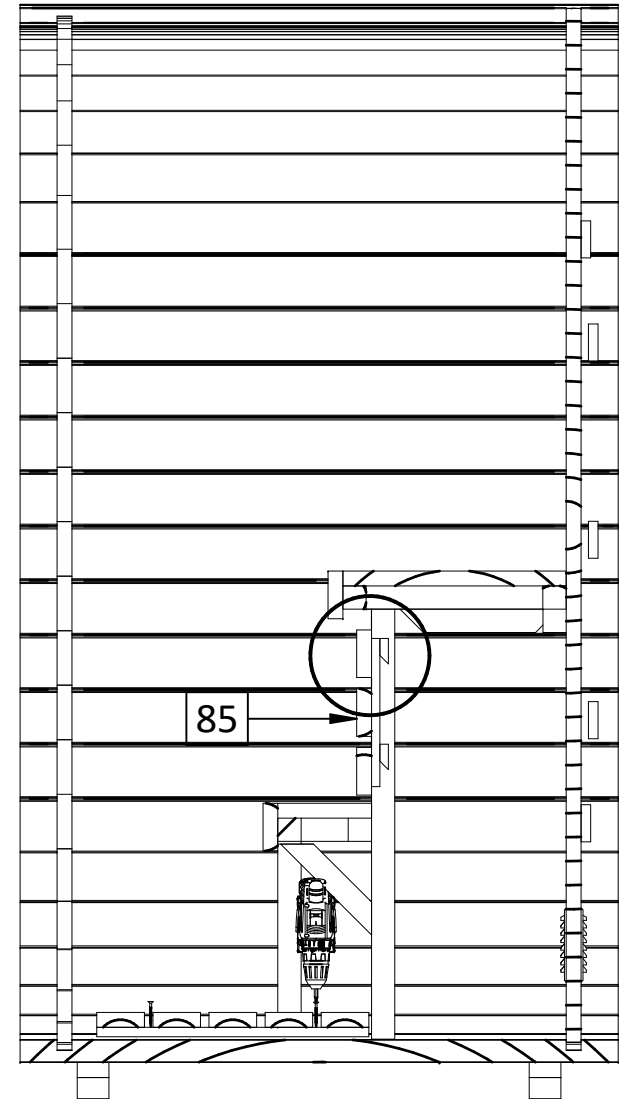
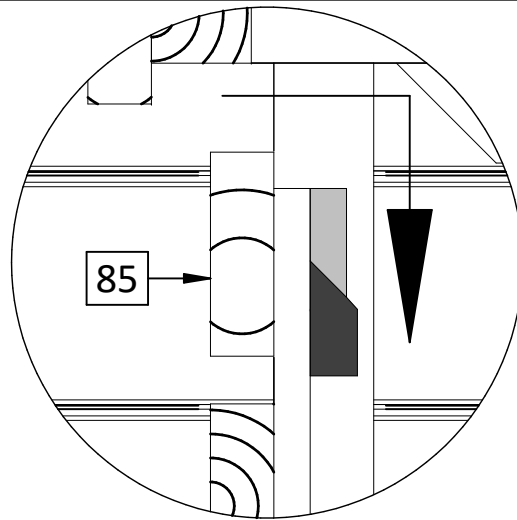
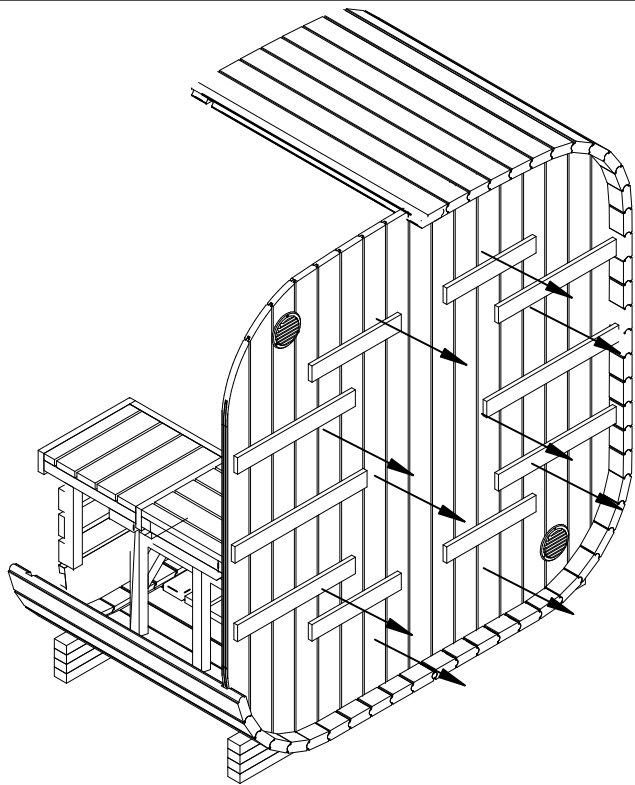

NB! Check also shingles installation manual inside the package.

# OPTIONAL

NB! Bitte bei Dachschindeln Montage beachten die Montageanleitung, welche in Dachschindeln Pakete liegt.

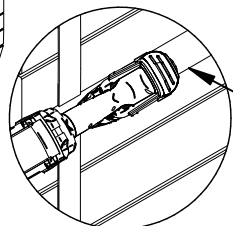
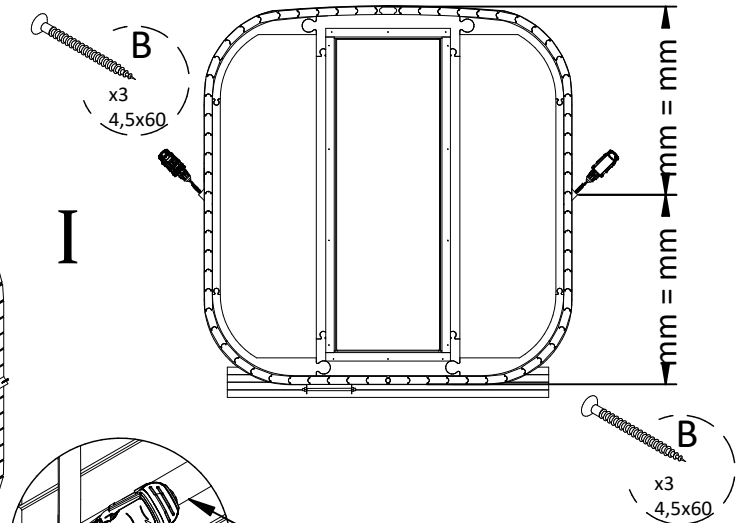
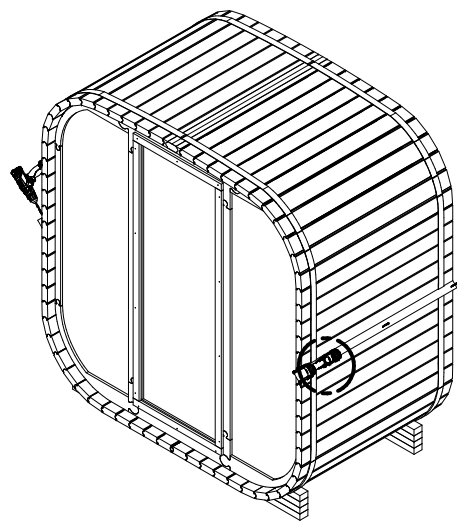

4

Please cut the clapping boards to size and use the other half on the other side.

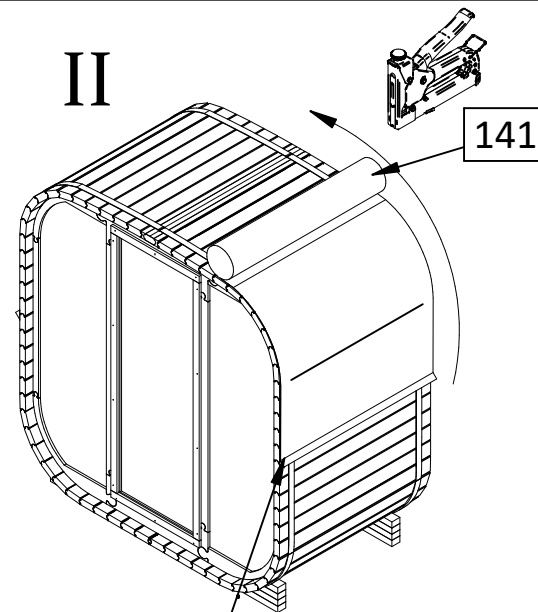

141

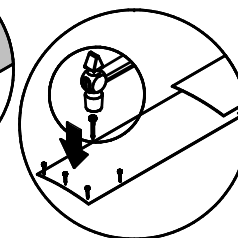
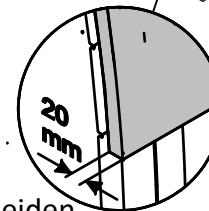

143

III

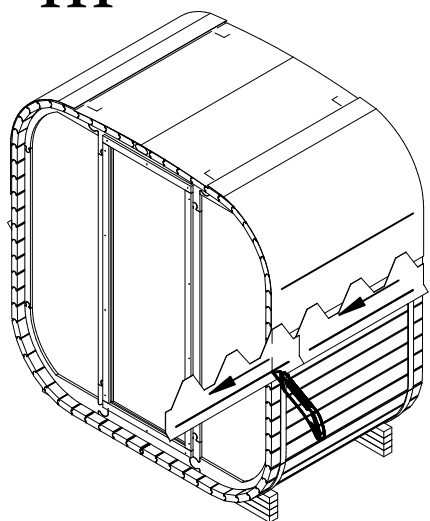

IV

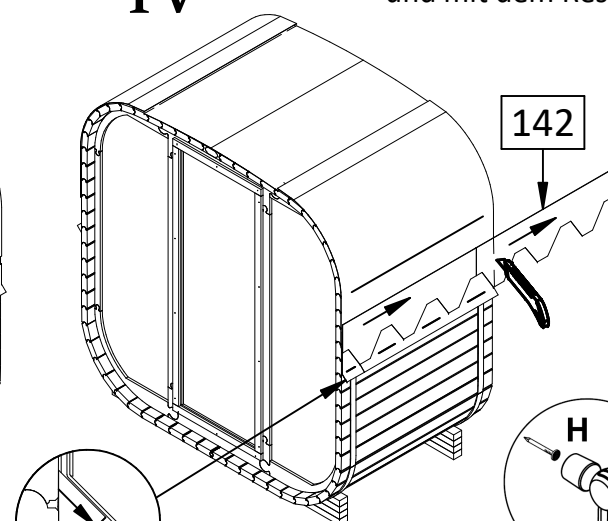

142

H

10

Bitte die Schindeln auf die richtige Länge schneiden und mit dem Reststück die neue Reihe anfangen.

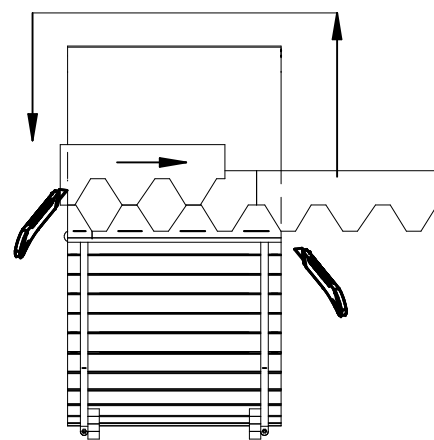

V

VI

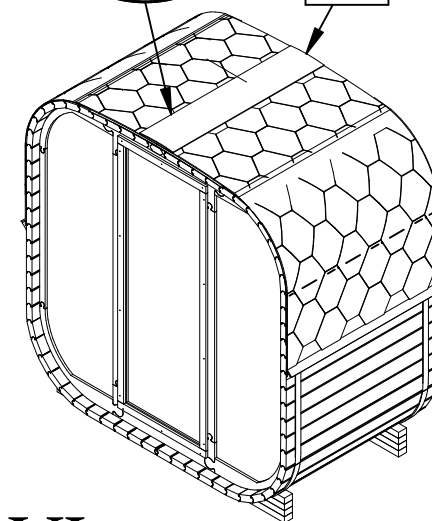

28.

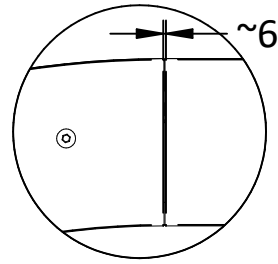

Attention! Leave a gap of 6 mm.

Achtung! Einen Zwischenraum von 6 mm lassen.

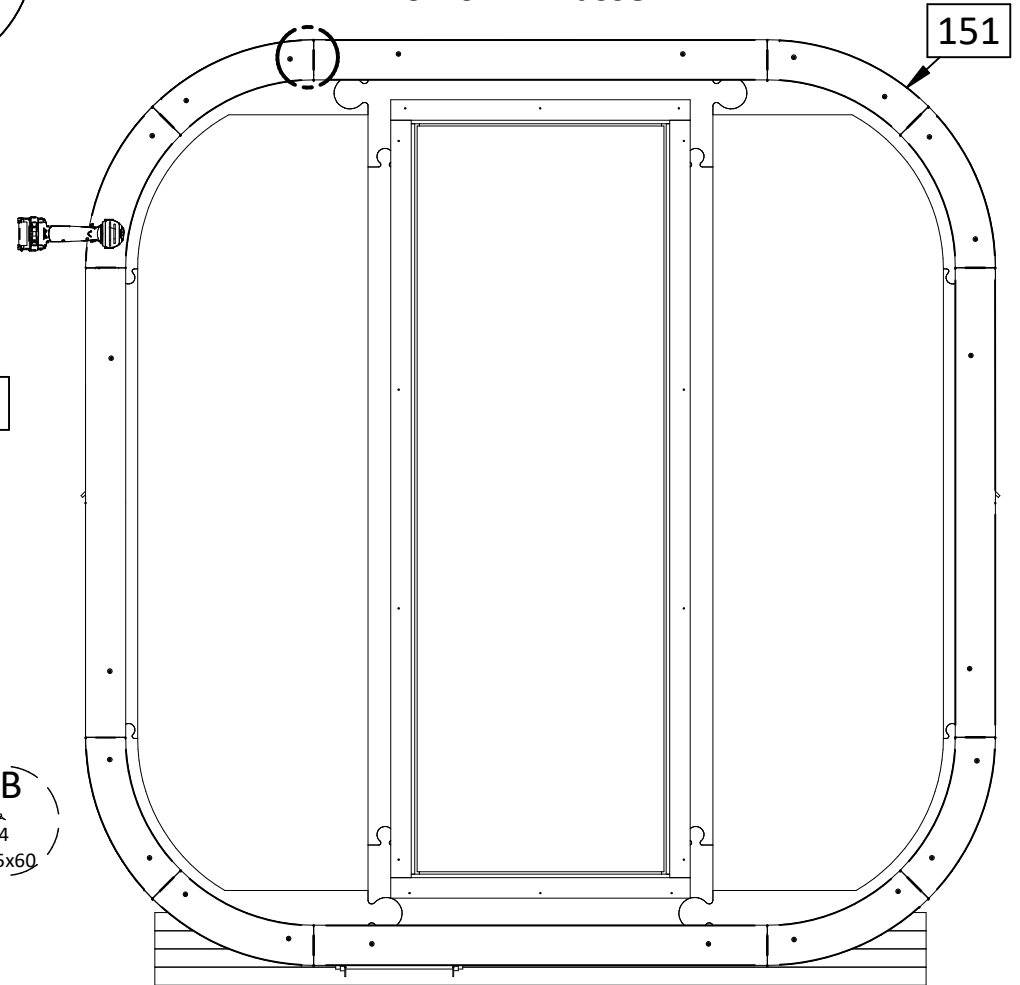
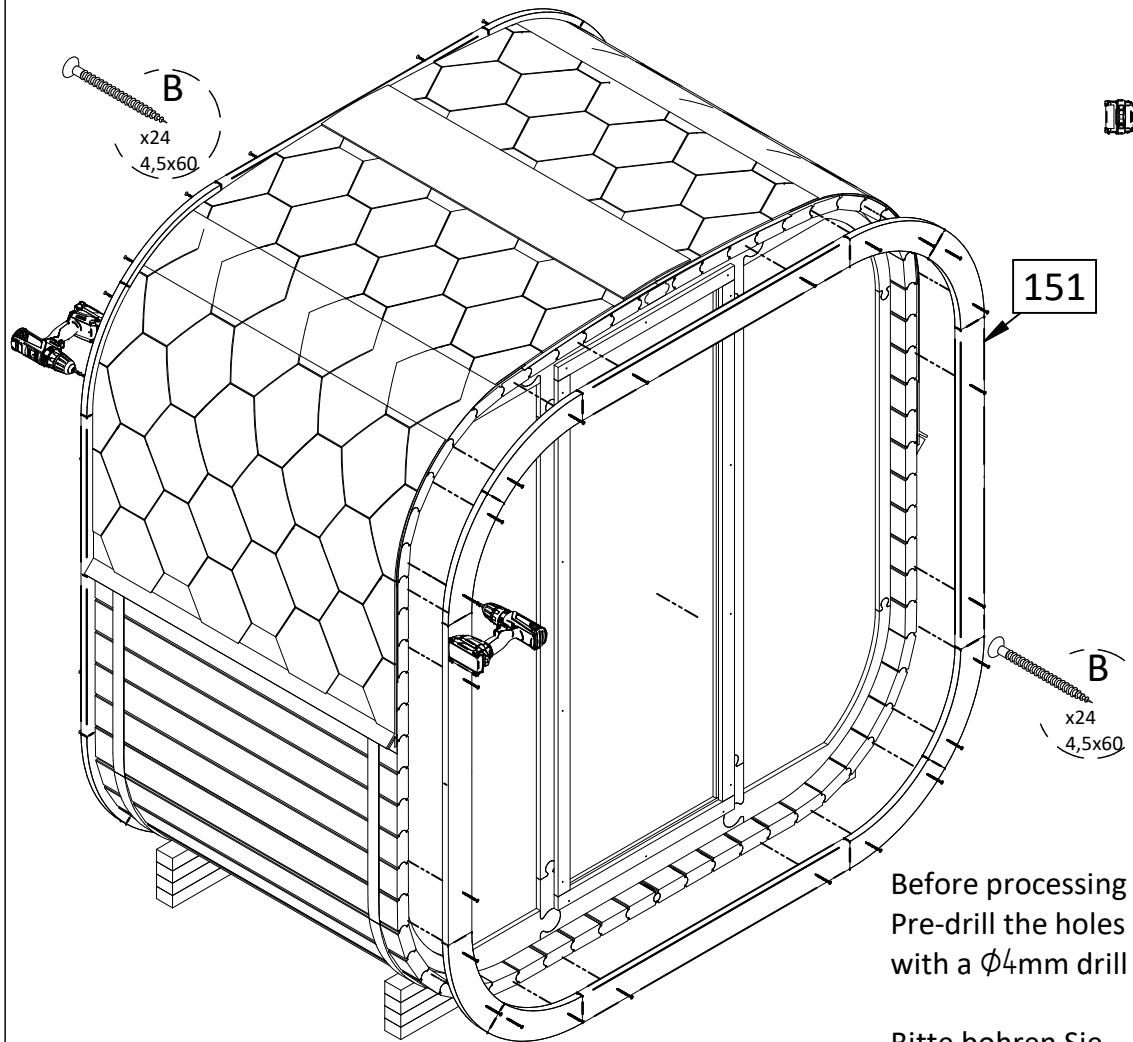

Before processing the screws.  
Pre-drill the holes  
with a  $\phi 4$ mm drill bit.

Bitte bohren Sie  
die  $\phi 4$ mm Löcher vor  
dem Schrauben vor

Falls nötig, schneiden Sie die Details in die passende Größe.  
If necessary, cut the details to the appropriate size